

LEGO

EXO-FORCE



TAKESHI



炎王



7712



4494879

2017



2x  
300401



2x  
255501



12x  
302301



2x  
302101

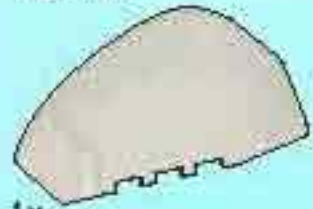

1x  
4286384



4x  
4142865



2x  
4160390



1x  
4118897



4x  
4125189



2x  
243121



10x  
4220519



1x  
4286399



3x  
458921



2x  
4140585



1x  
9342



10x  
241221



4x  
654121



2x  
4227649



1x  
4220675



4x  
4206482



9x  
618841



2x  
4107068



4x  
4277925



1x  
4286377



2x  
4160392



2x  
389424



4x  
4201615



4x  
4294741



4x  
4180483



8x  
4247771

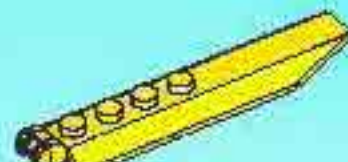

6x  
4294480



2x  
4107800



3x  
4144412



2x  
302324



2x  
370924



1x  
4260192



2x  
4107750



1x  
373824



2x  
241224



2x  
428724



2x  
4271087



2x  
4271084



2x  
244424



2x  
4140801



2x  
4282746



2x  
300326



1x  
4275826



2x  
4155558



4x  
4121715



2x  
655826

6x  
242026

2x  
241926

1x  
370526

2x  
370726

2x  
416226

1x  
4158848

4x  
302426

2x  
302326

1x  
4225201

1x  
4183060

2x  
4124096

1x  
303426

1x  
374726

2x  
4278359

6x  
4159335

3x  
4142135

2x  
4120017

7x  
370026

1x  
4140430

1x  
4162857

1x  
4288258

1x  
618849

1x  
4211622

4x  
4211807

6x  
4211483

1x  
4211775

2x  
4211451

4x  
4211632

2x  
4211804

1x  
4211881

2x  
4211395

1x  
4211350

2x  
4211469

2x  
4211741

6x  
4211088

1x  
4263624

2x  
4218201

2x  
4225973

4x  
4227395

4x  
4235573

1x  
4287973

1x  
4143325

1x  
4287972

2x  
4211084

2x  
4210883

4x  
4211133

2x  
4211001

7x  
4211094

2x  
4211000

2x  
4289542

1x  
4283931

8x  
4494600

2x  
4210935

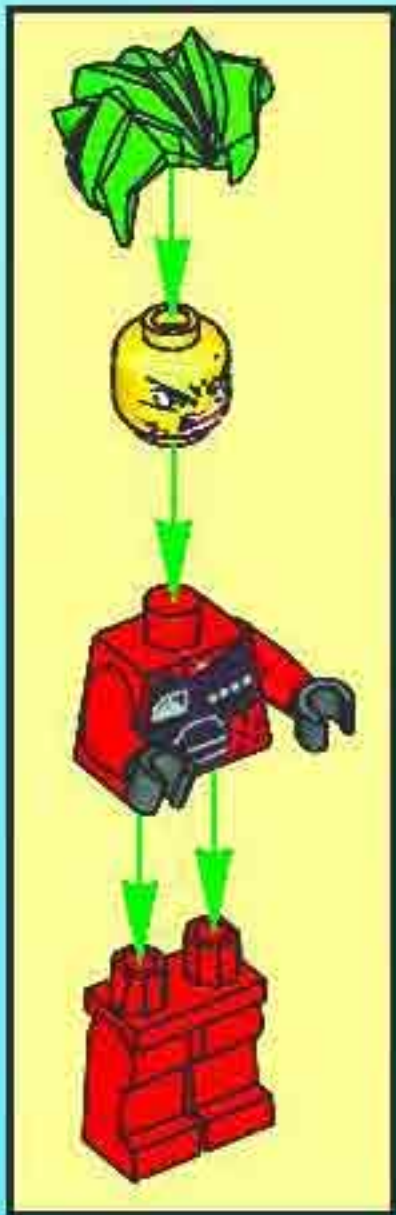
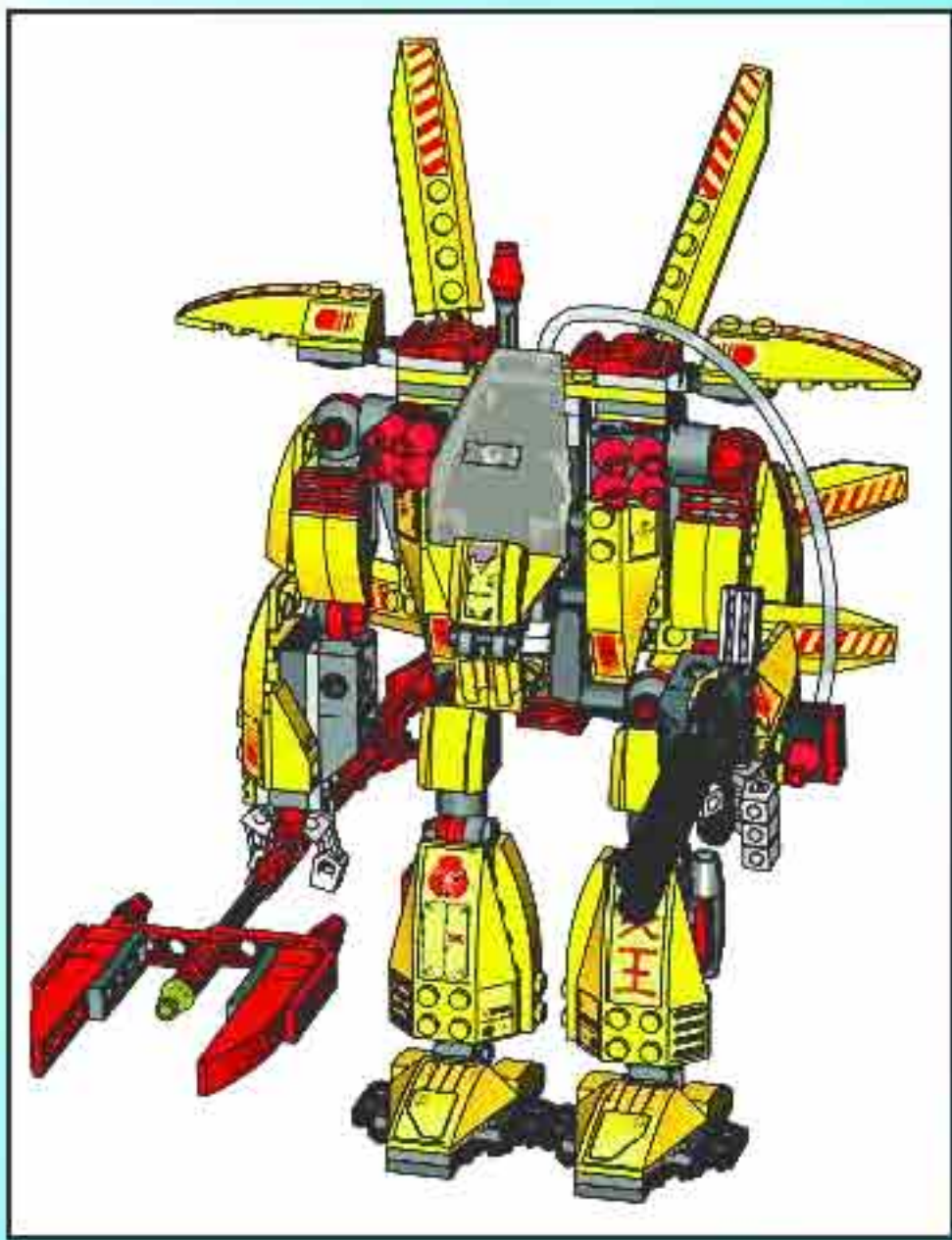



1

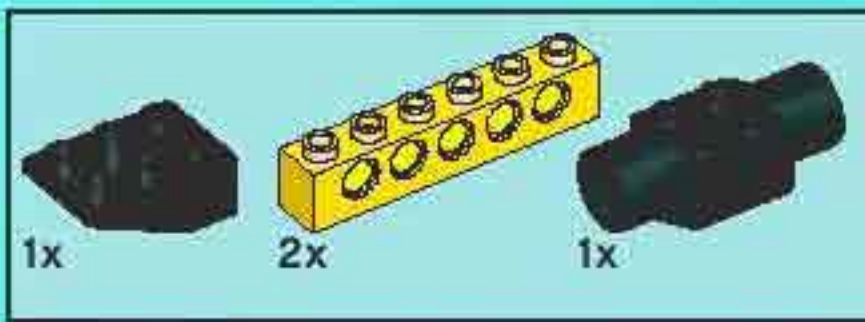

2

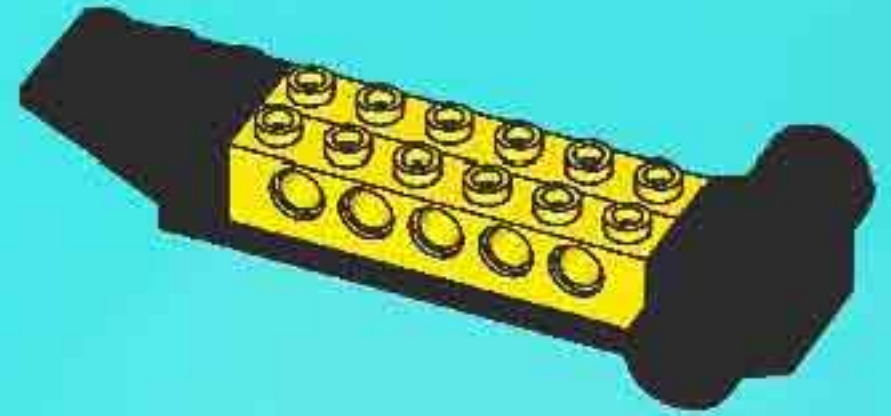

3

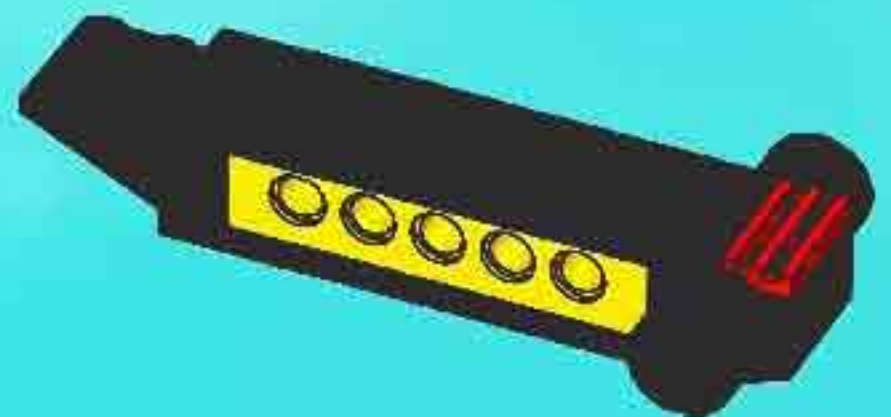

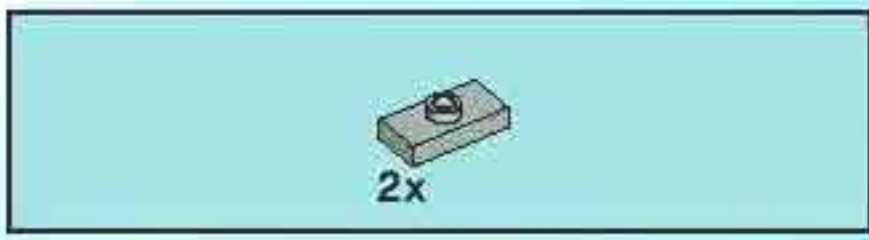

4

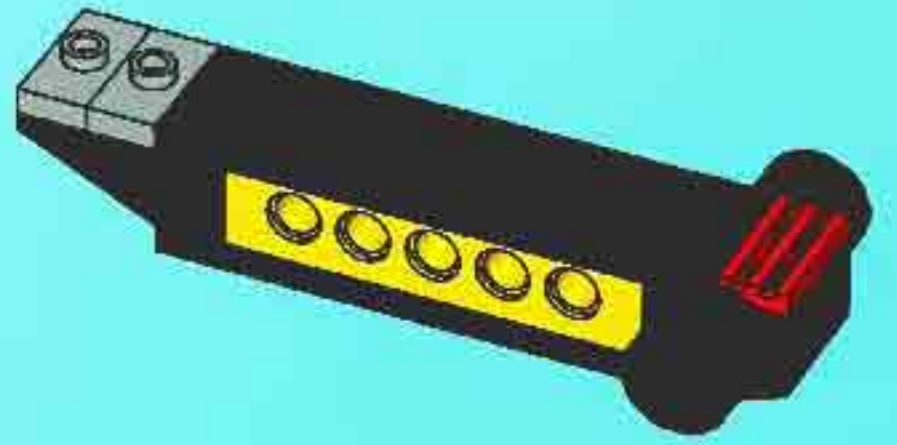

5

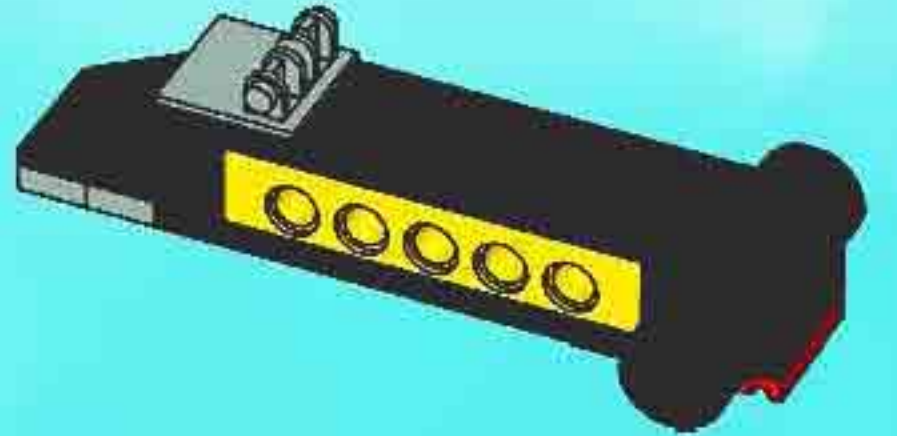

6

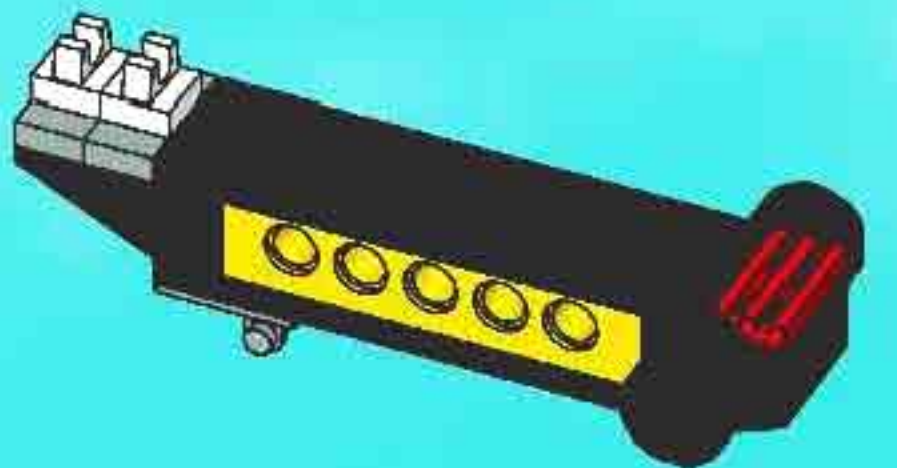

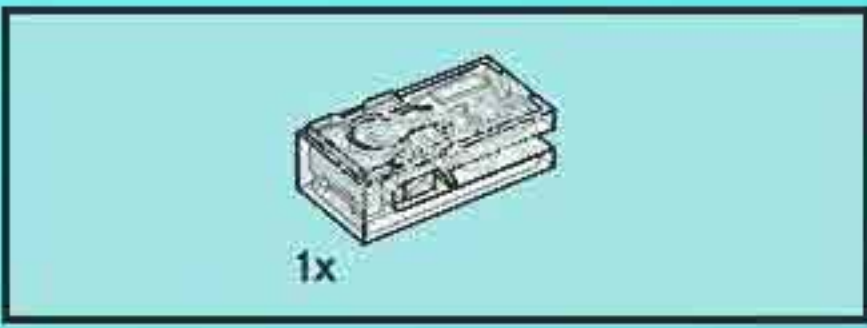

7

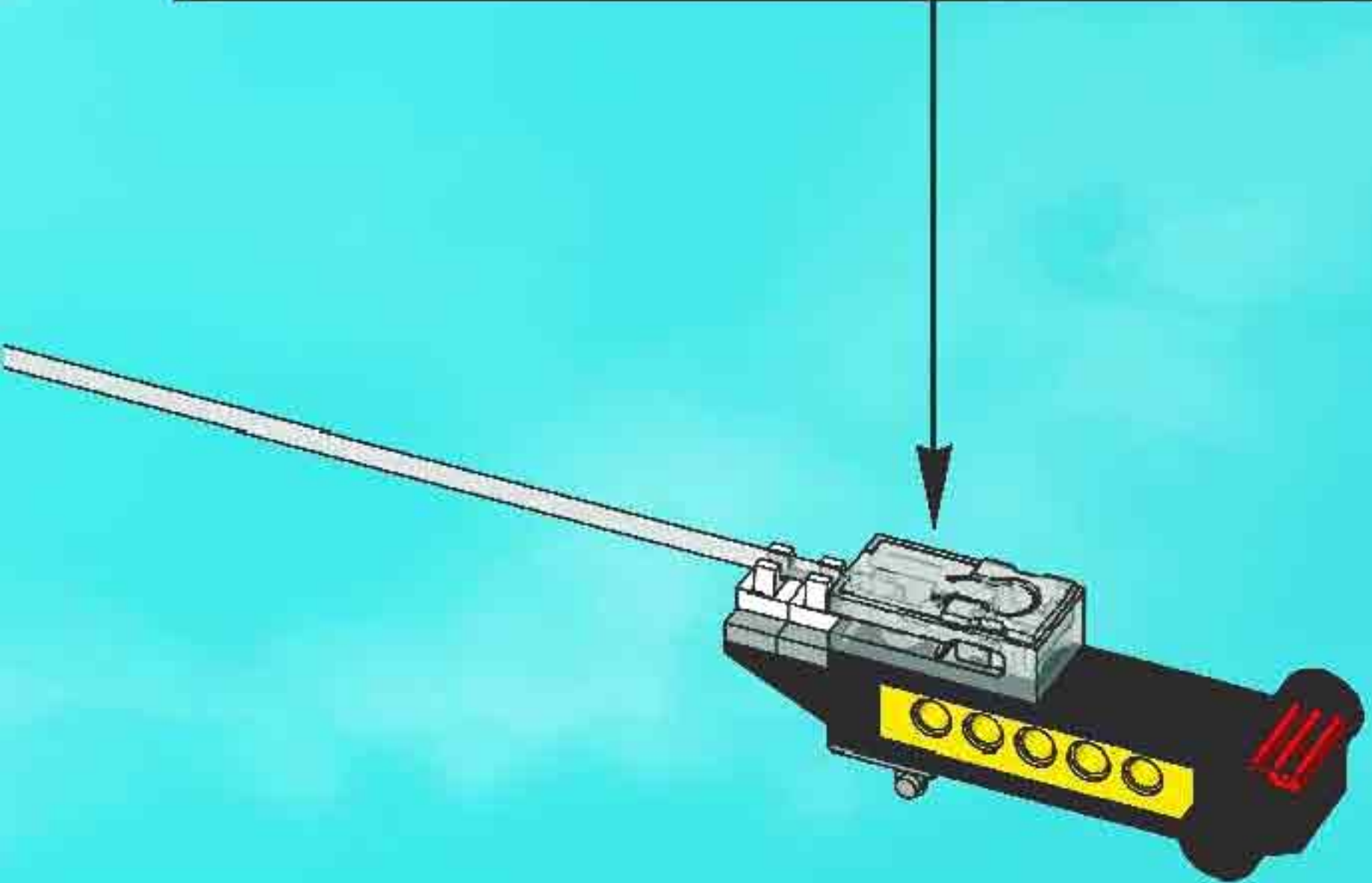
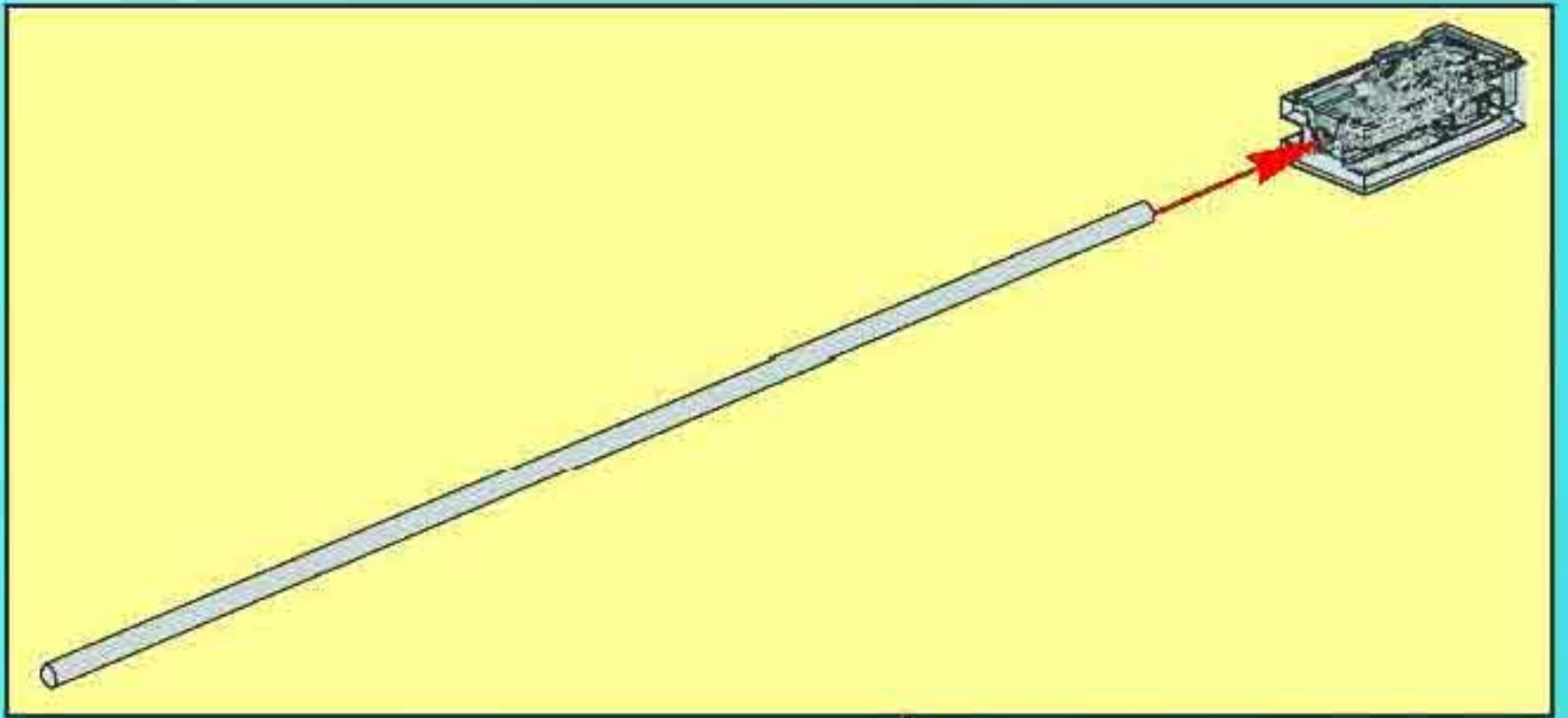

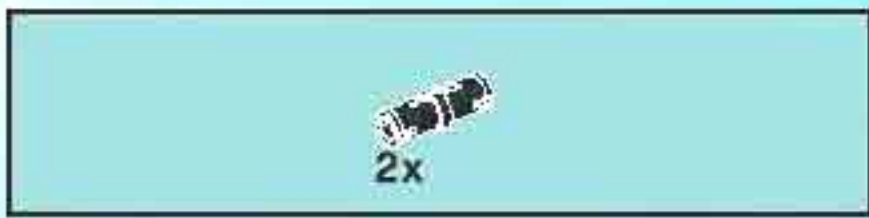

8

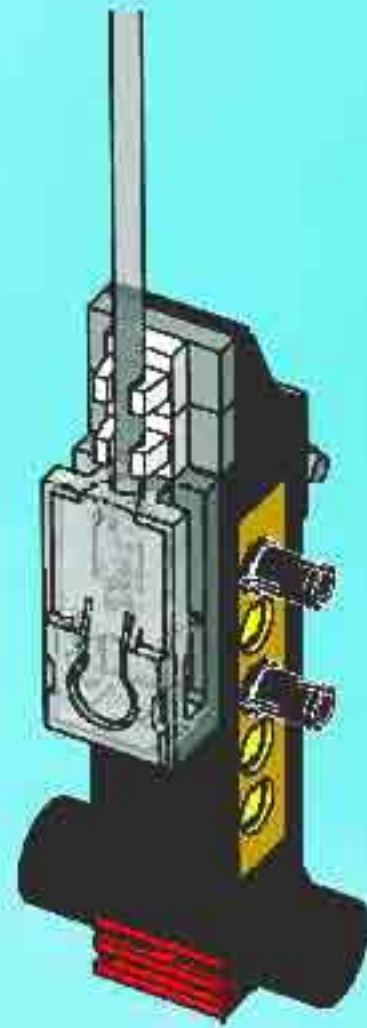

9

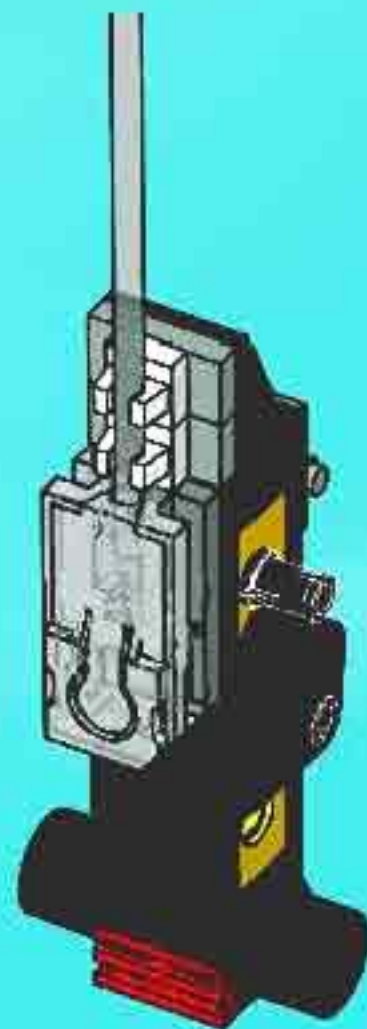

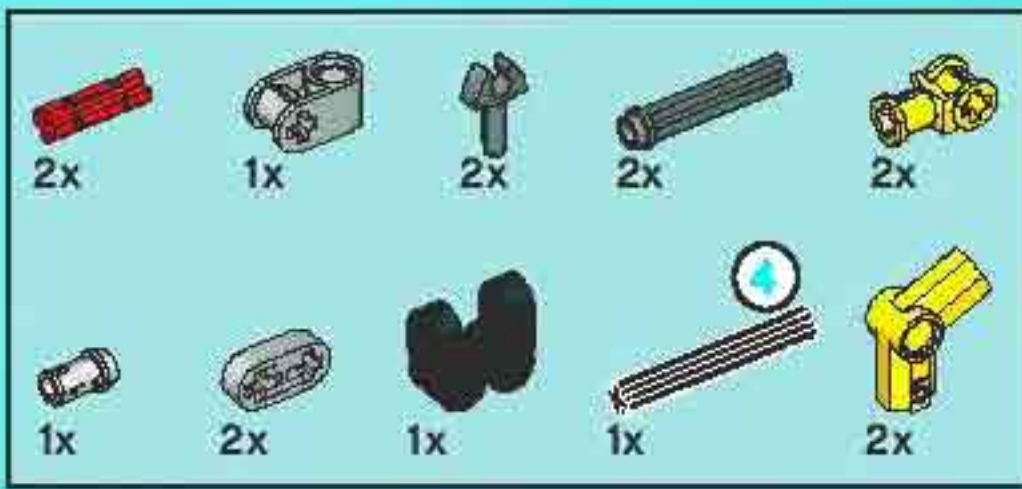

# 10

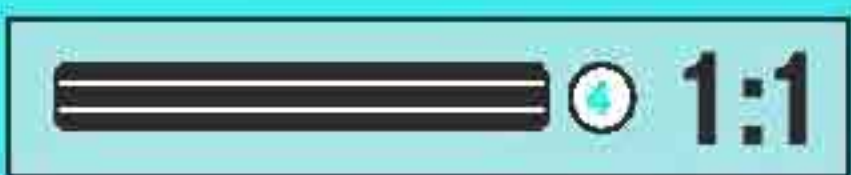
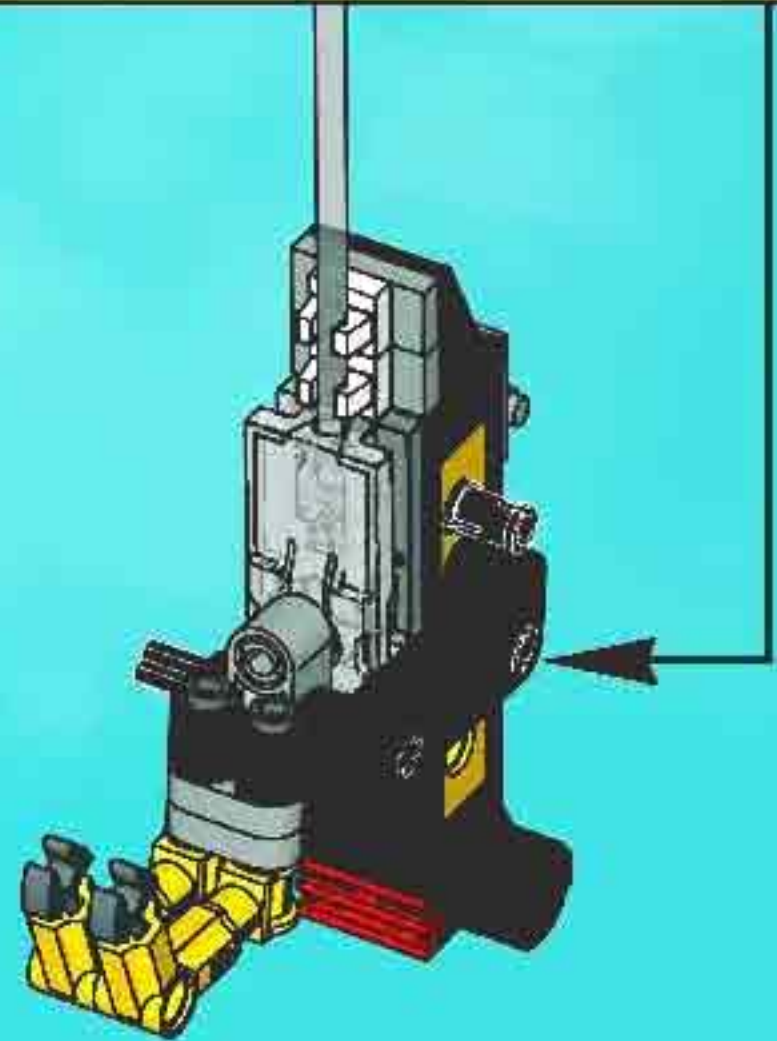
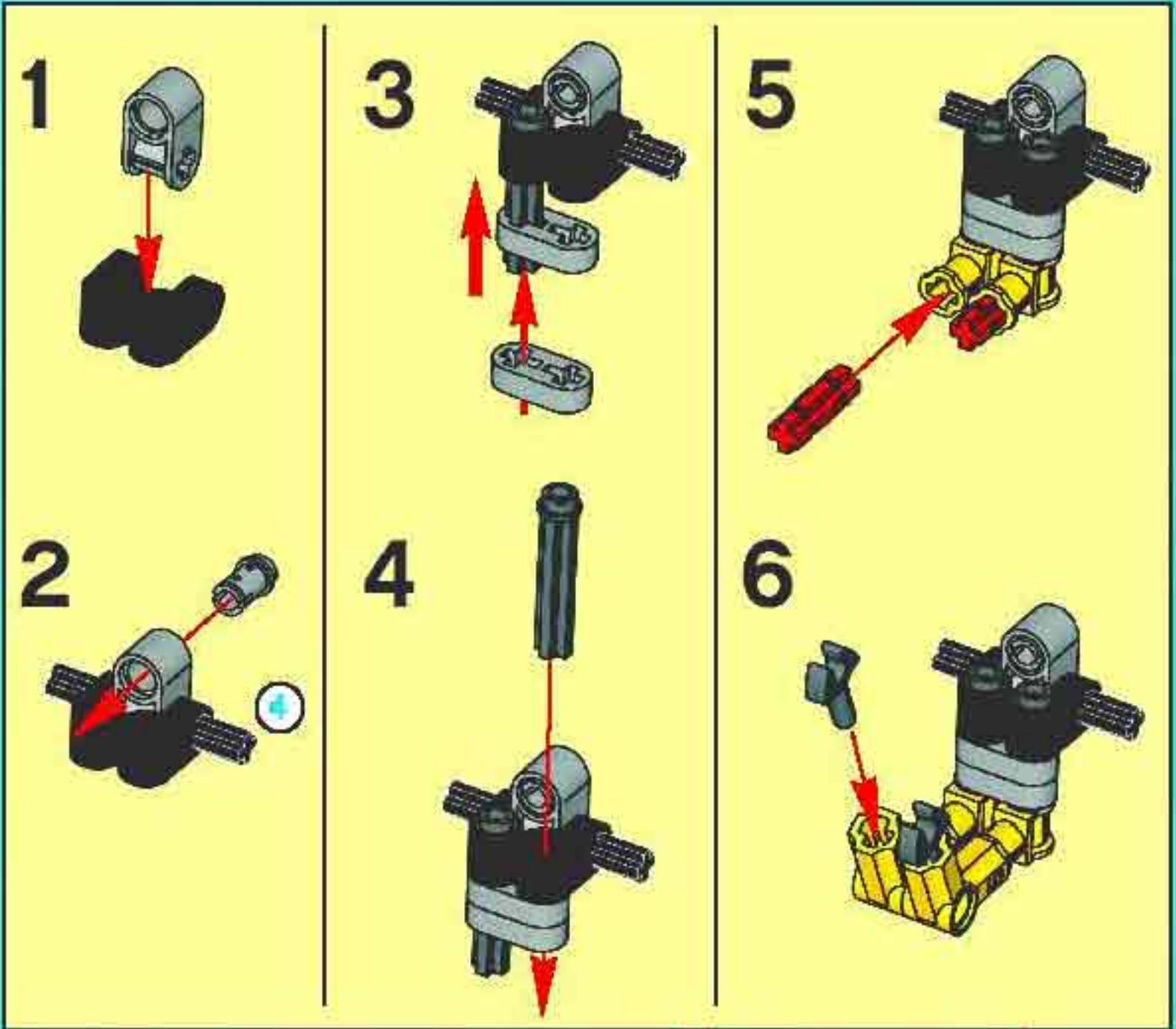

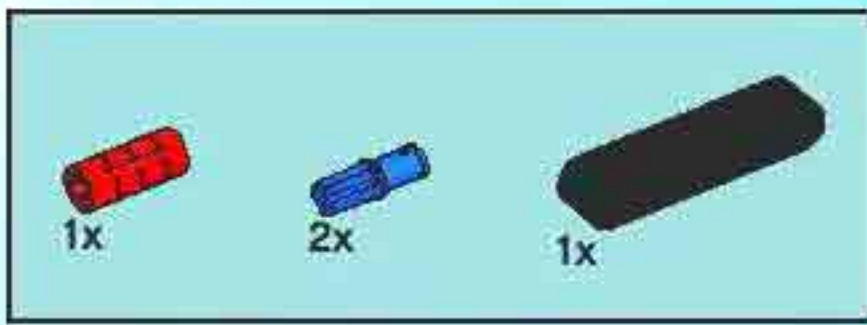

11

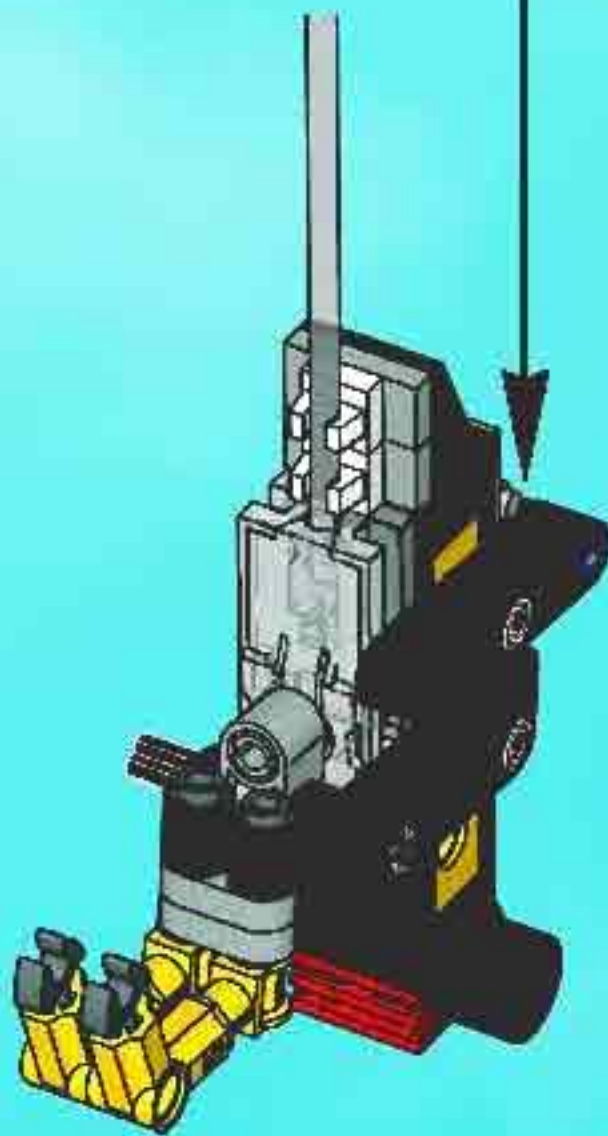
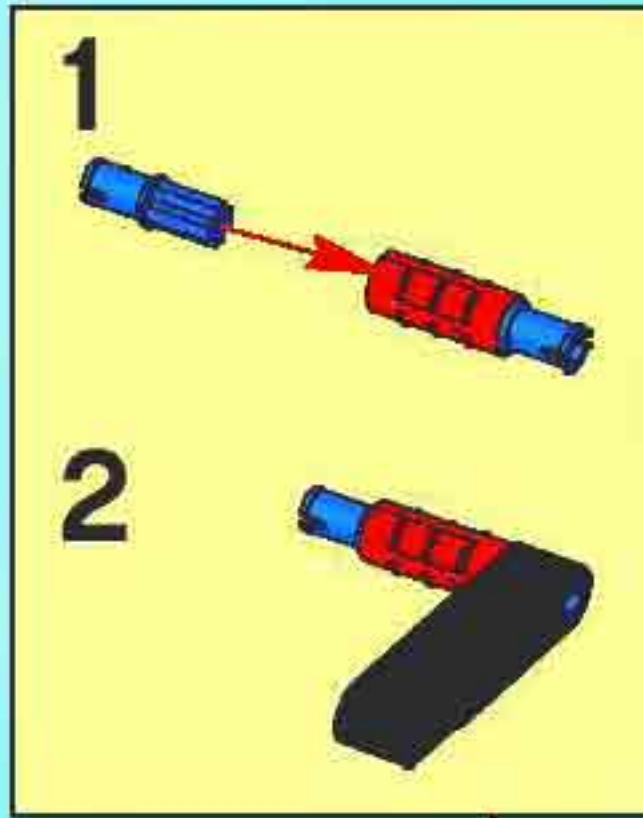



12

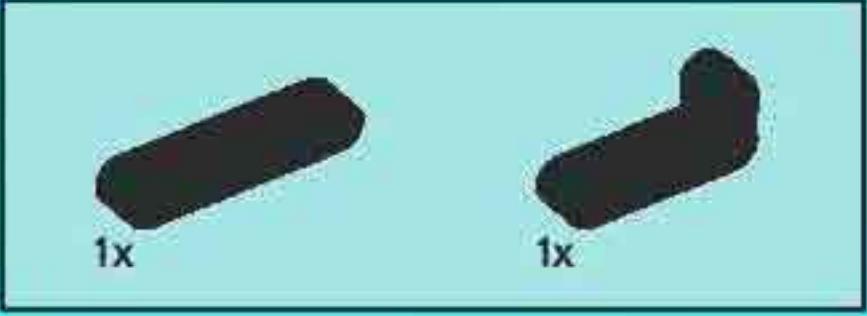
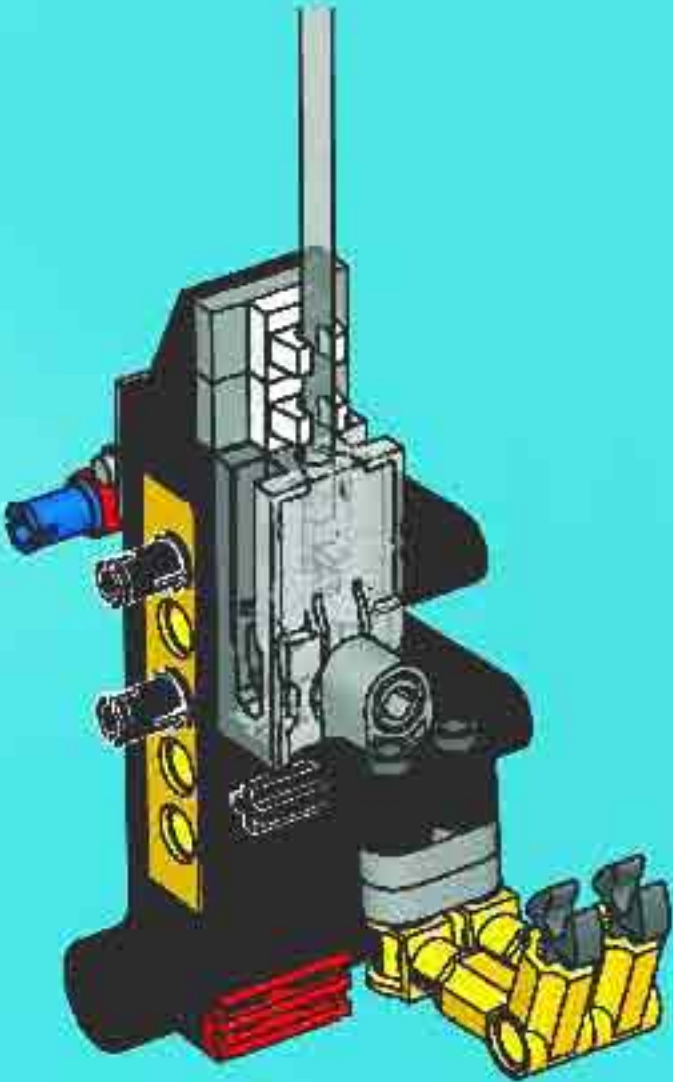

13

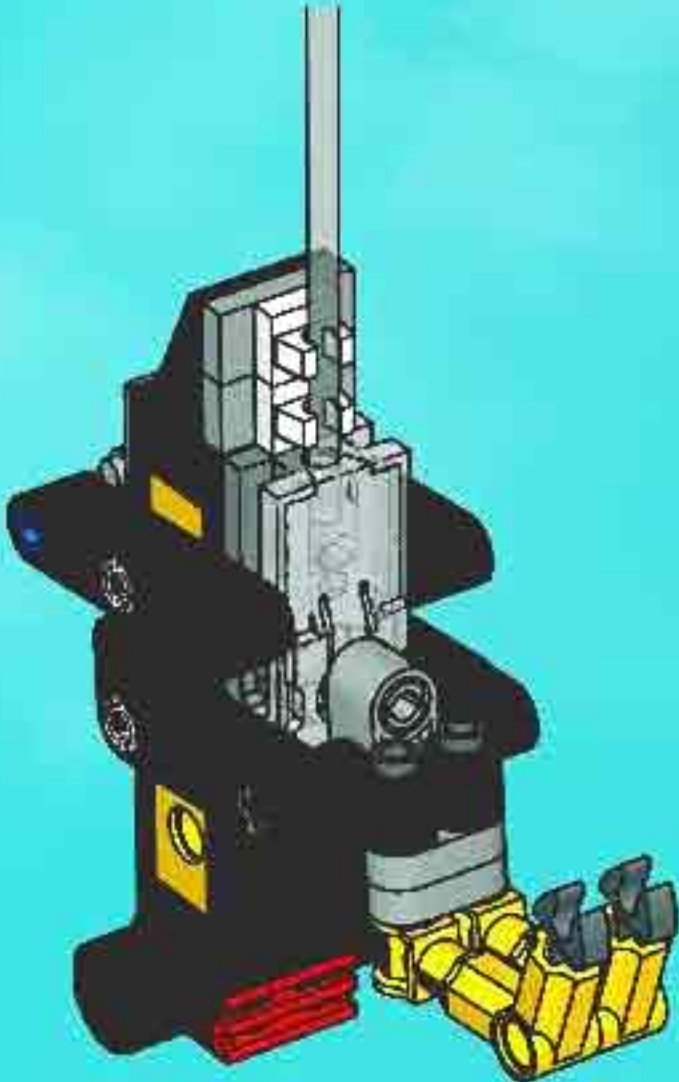

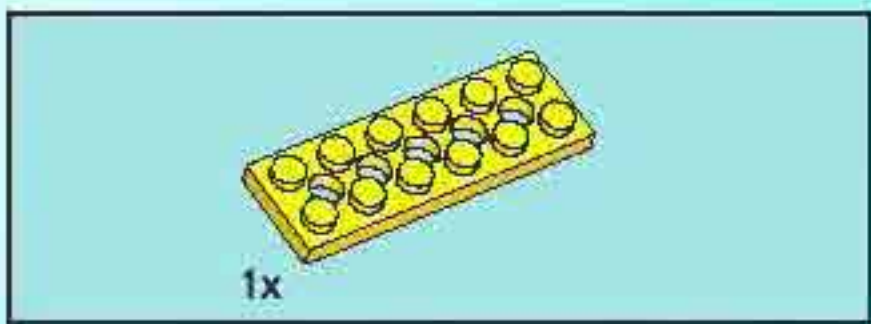
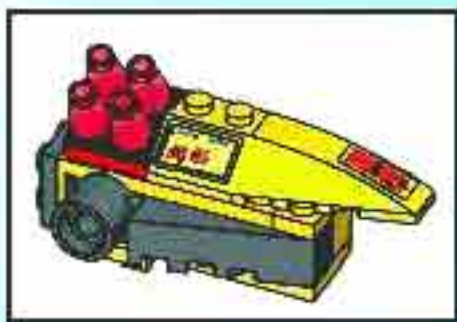

**1**

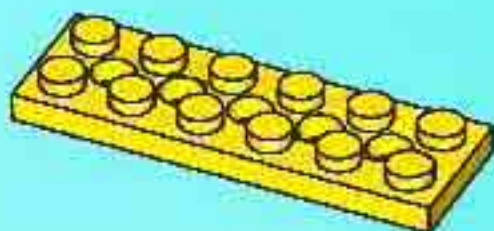

**2**

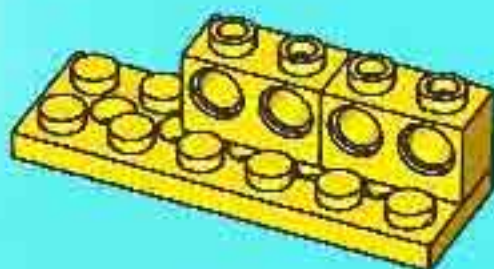

**3**

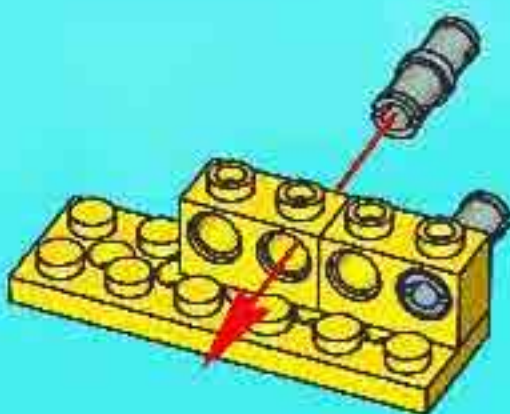

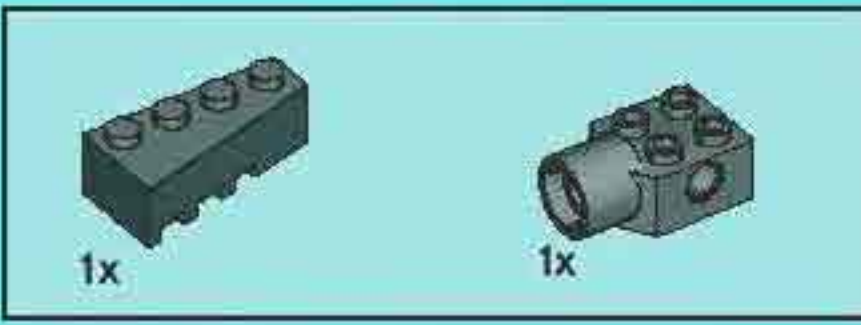

4

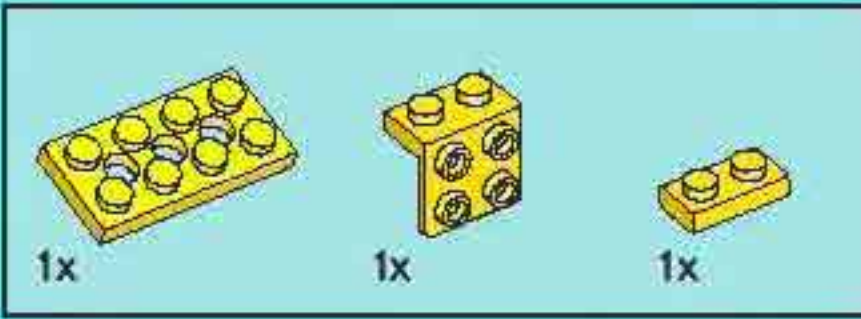
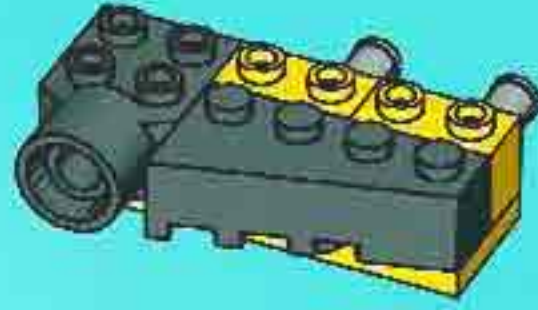

5

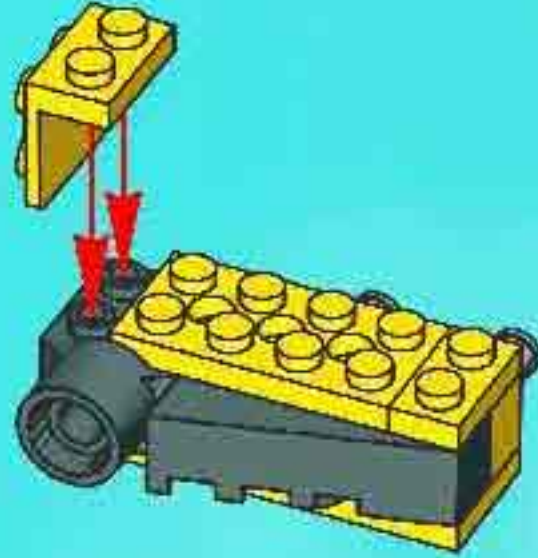

6

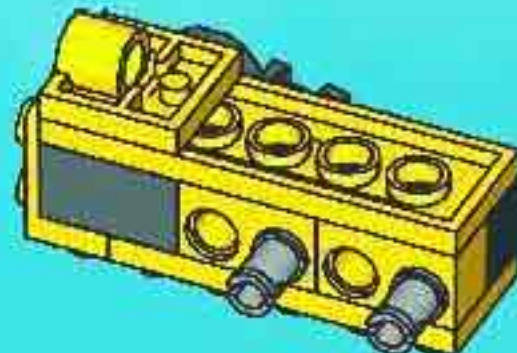

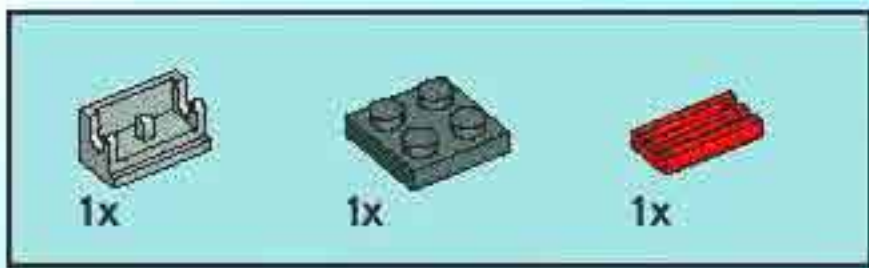

7

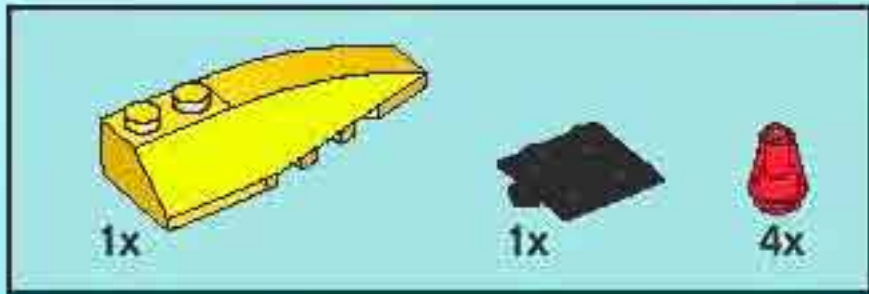
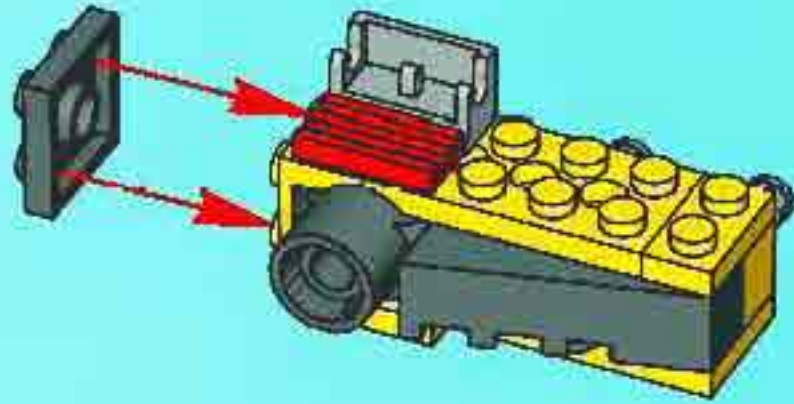

8

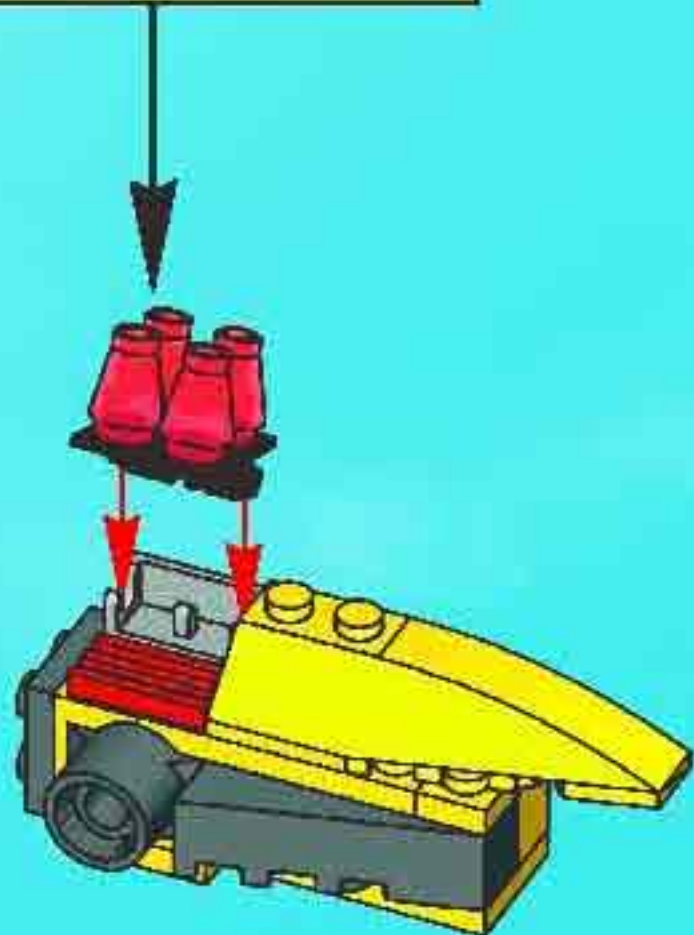

9

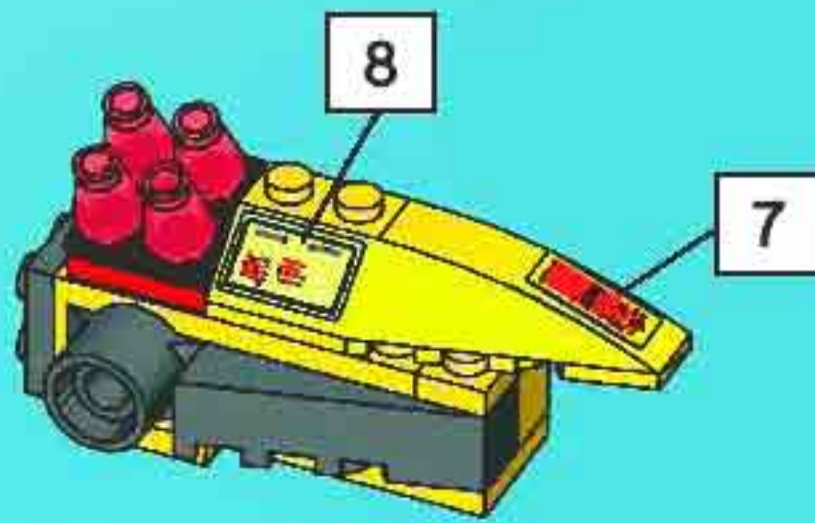

14

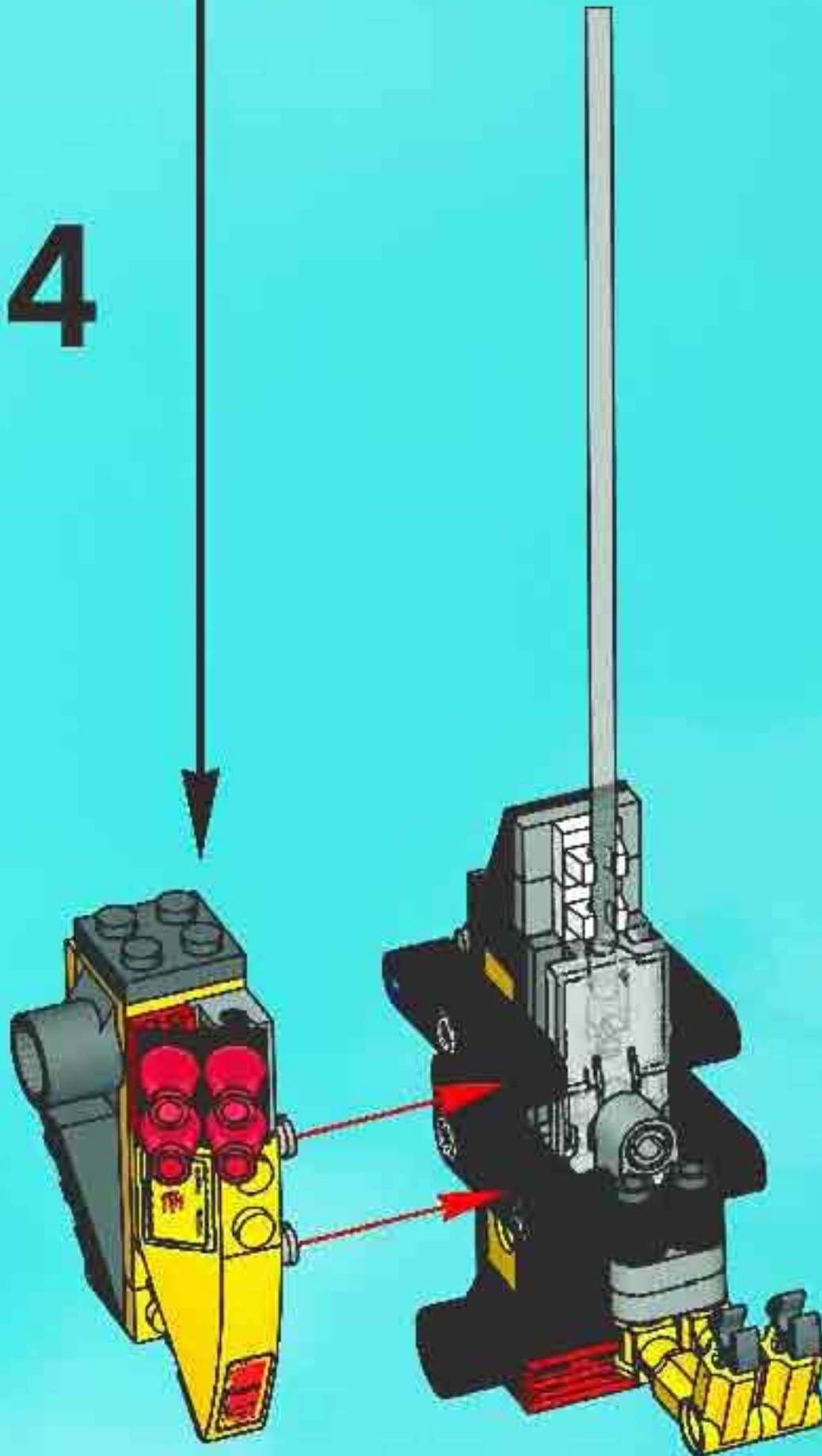

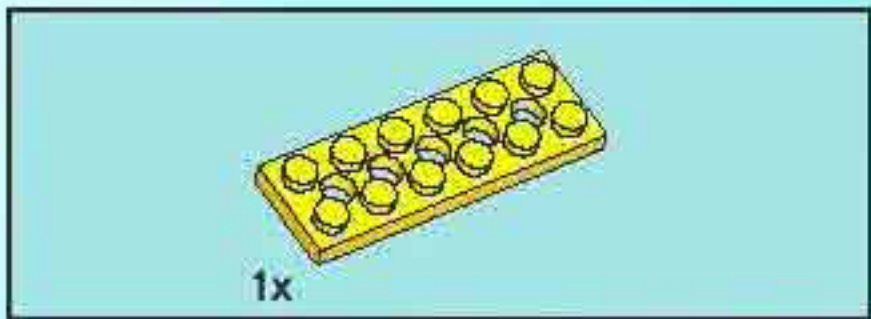
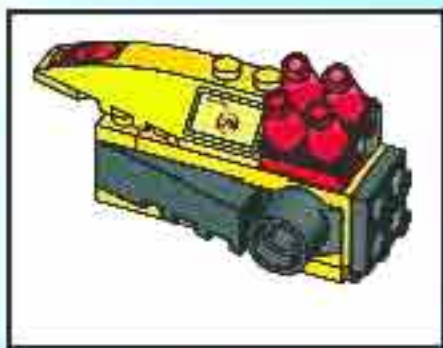

**1**

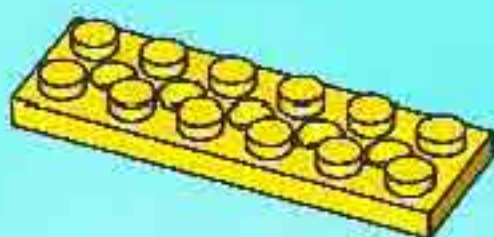

**2**

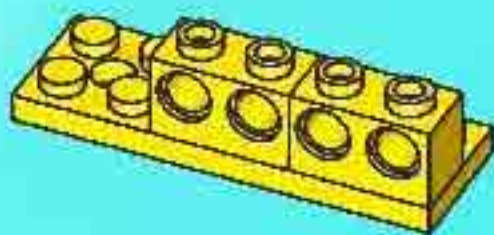

**3**

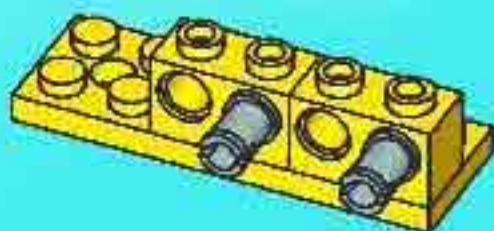

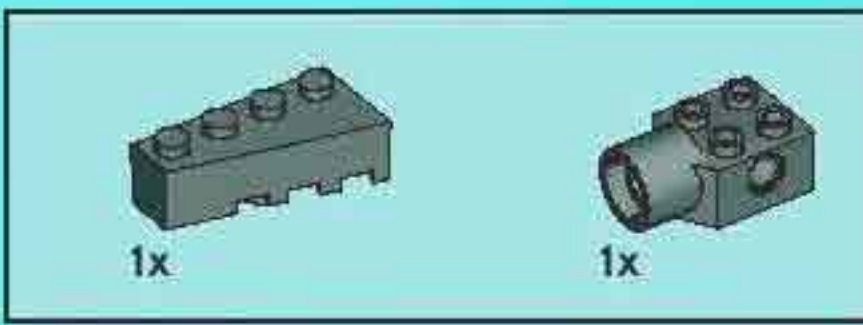

4

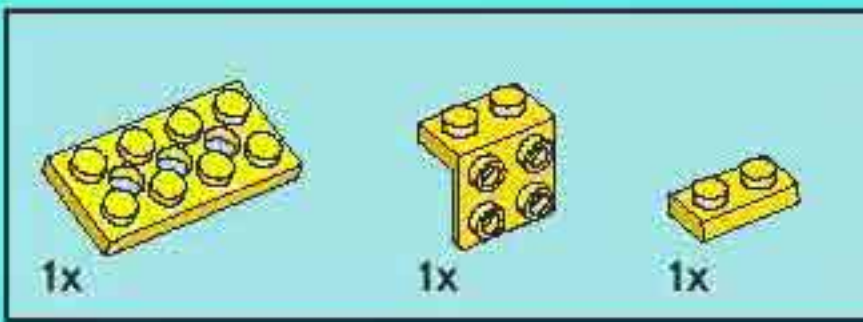
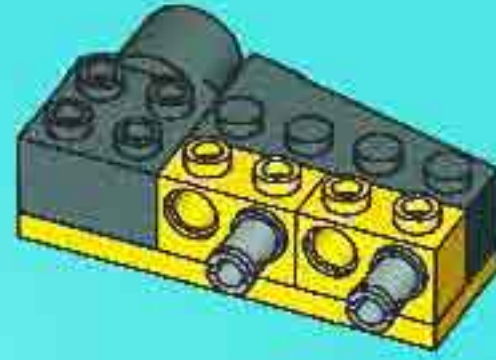

5

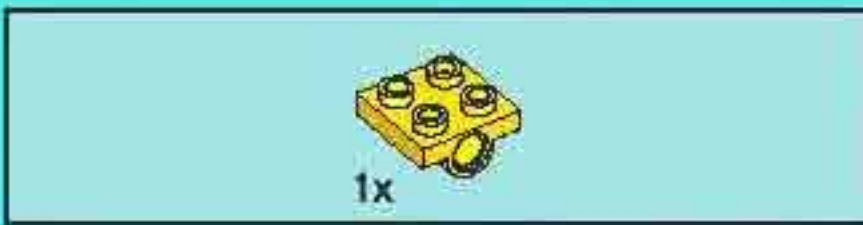
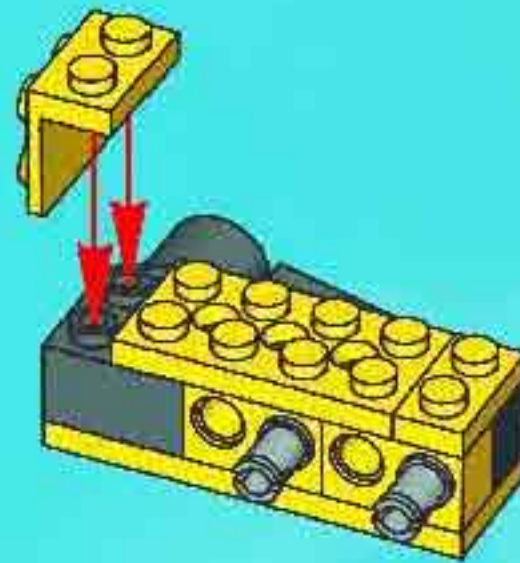

6

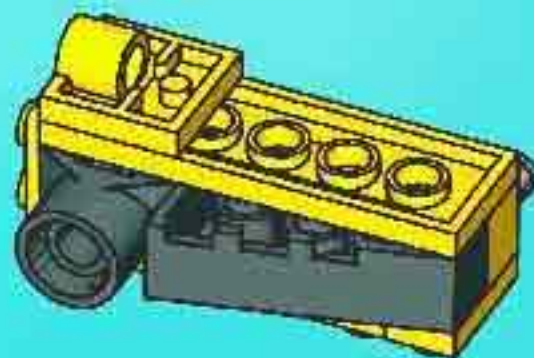

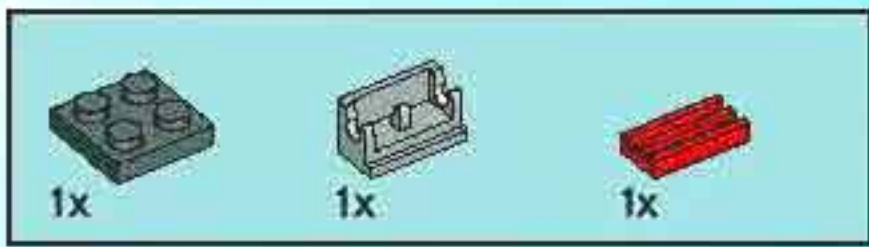

7

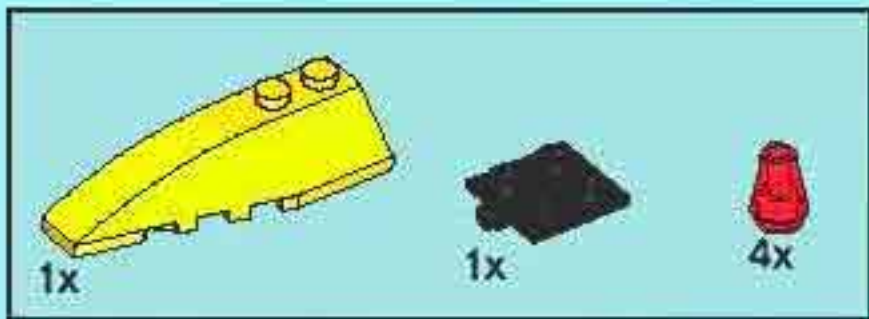
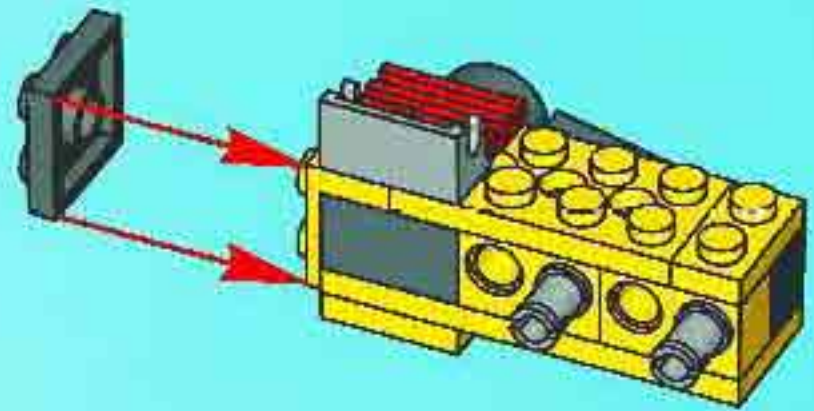

8

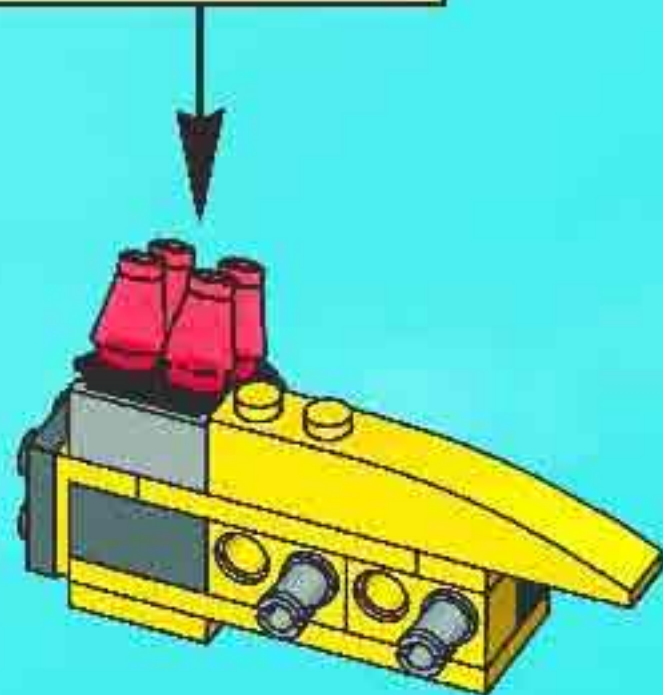

9

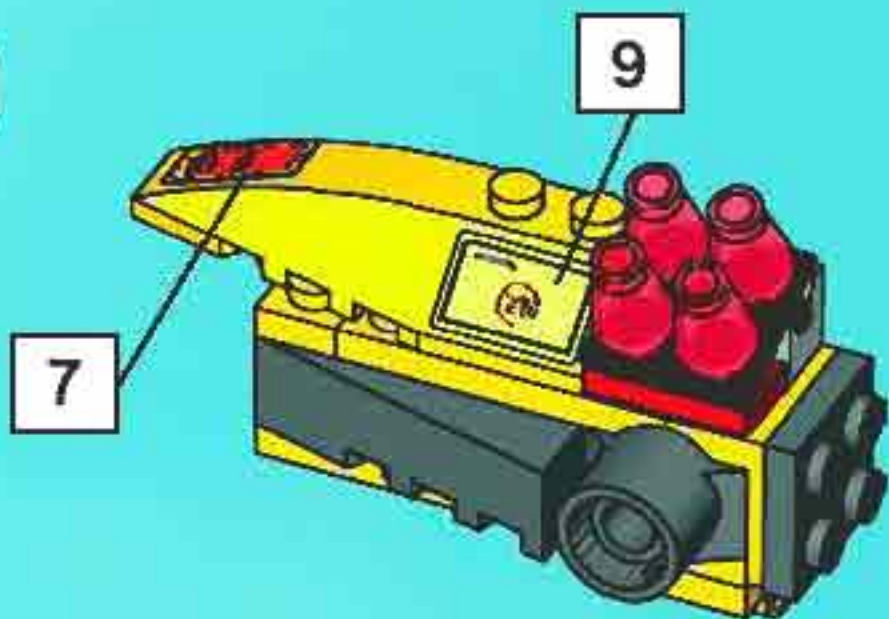

7

9

15

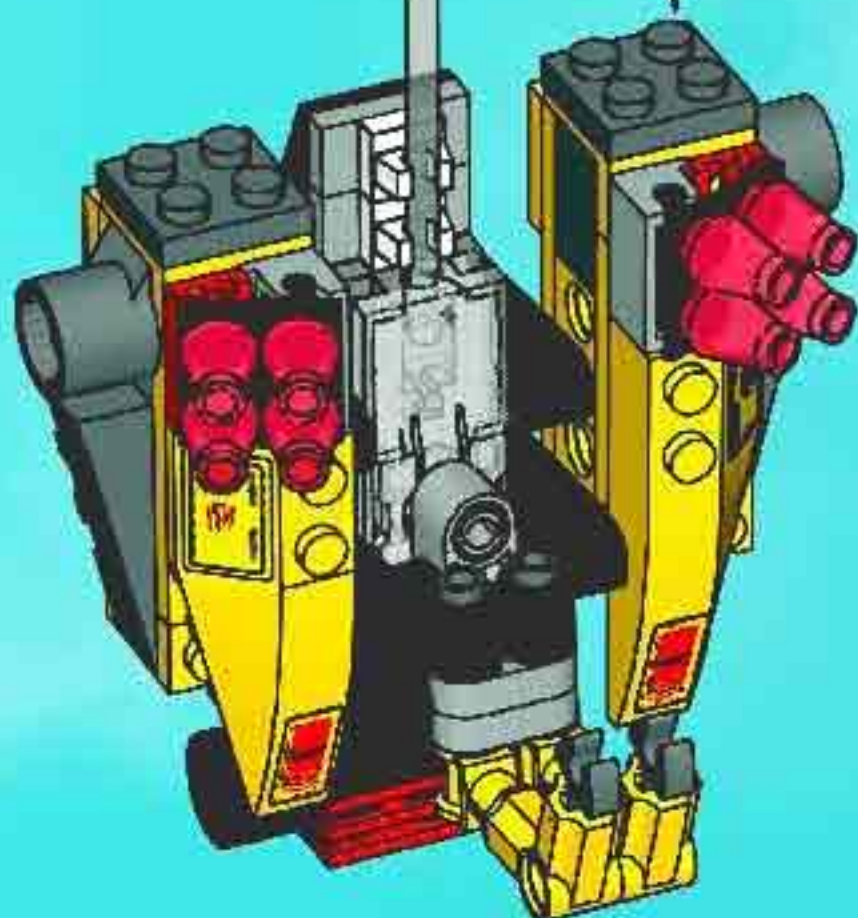

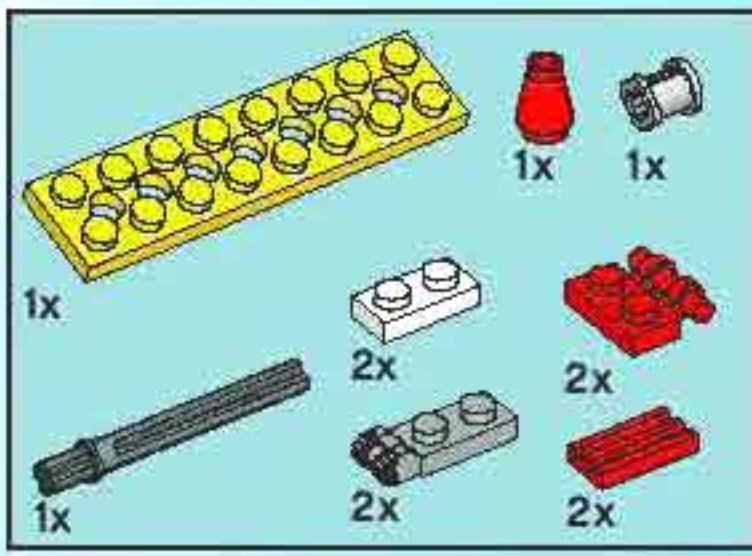

16

1

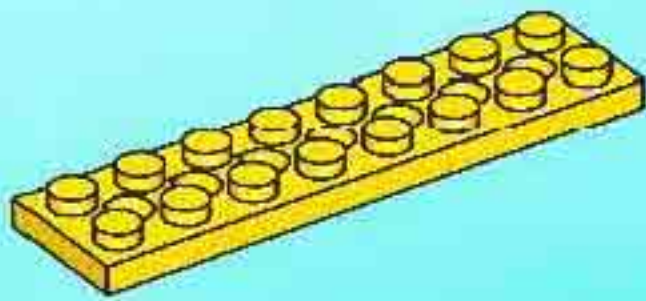

2

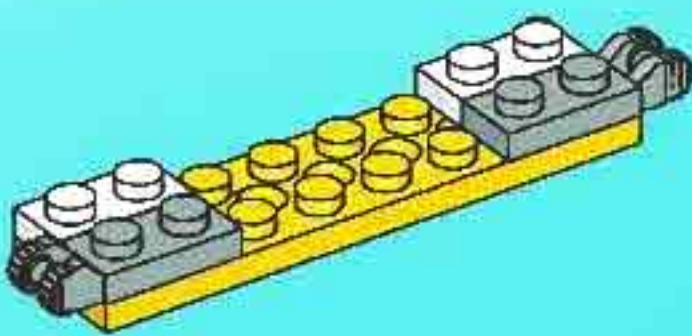

3

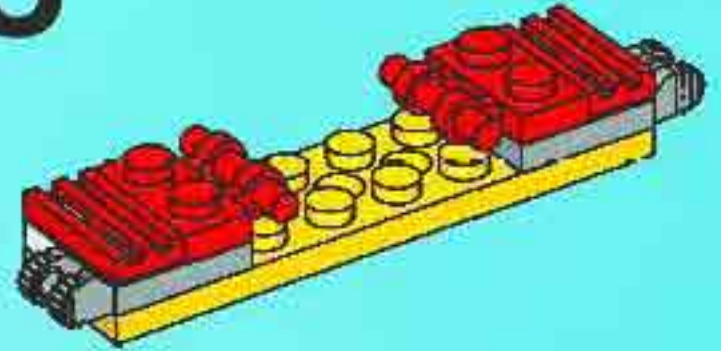

4

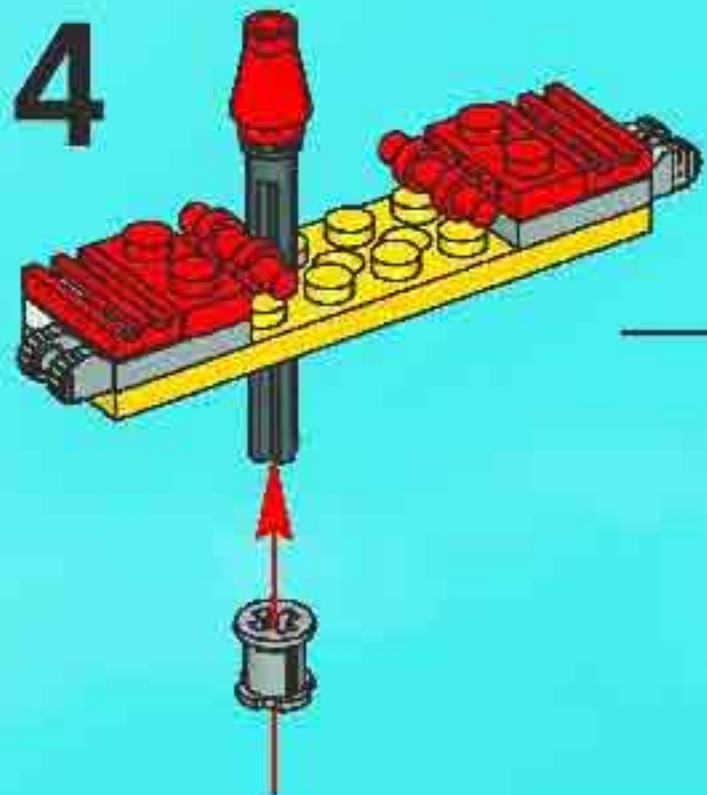

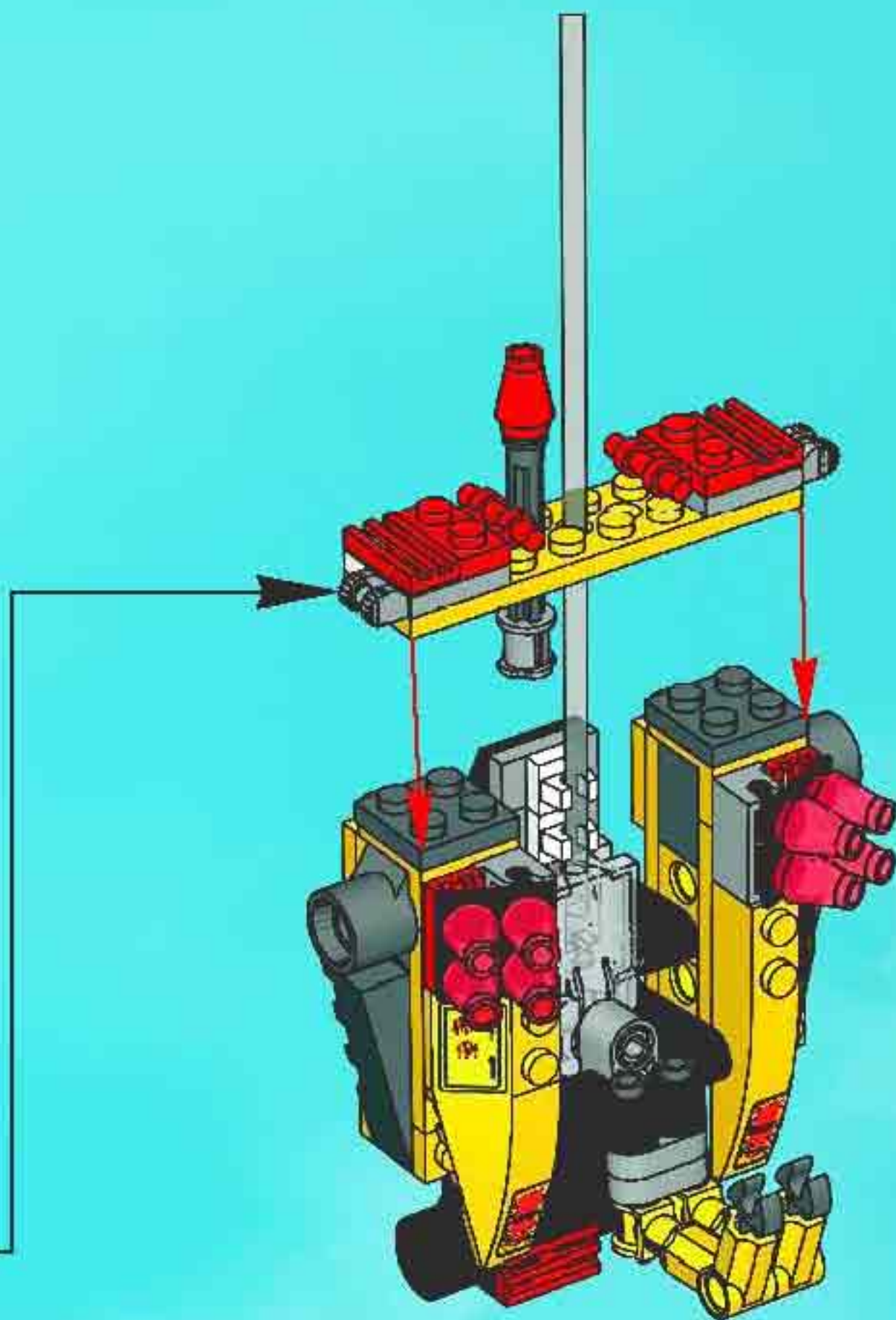

1

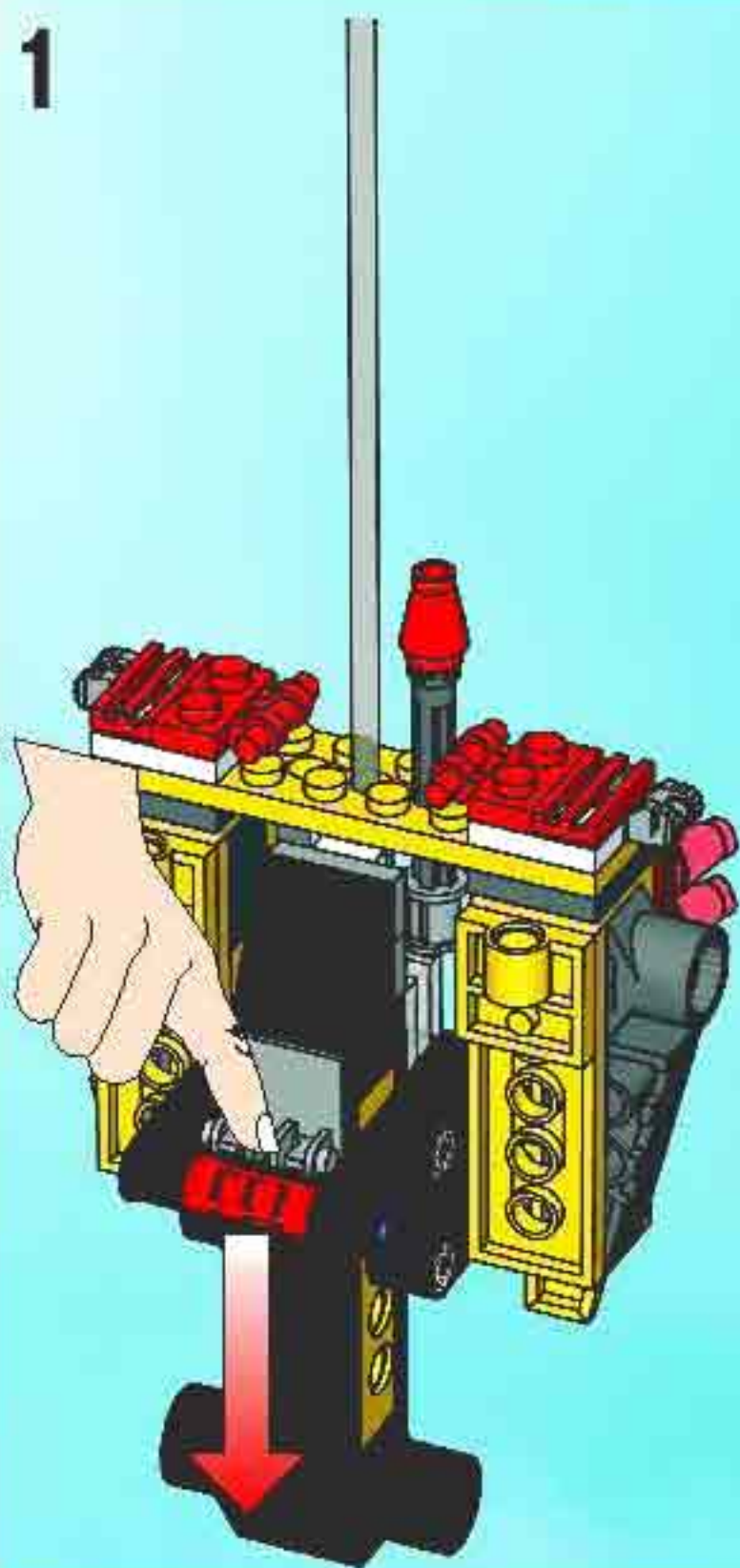

2

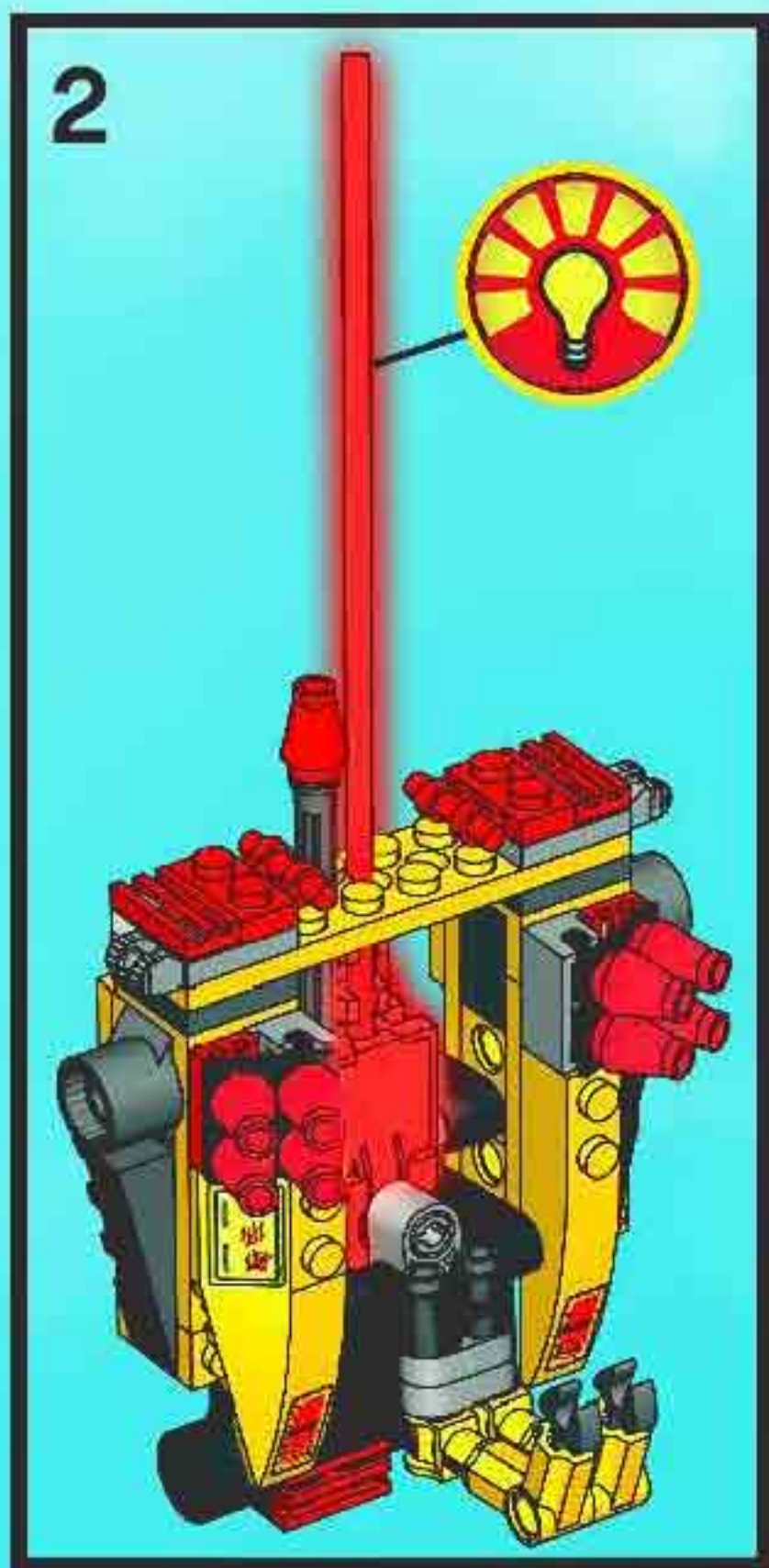

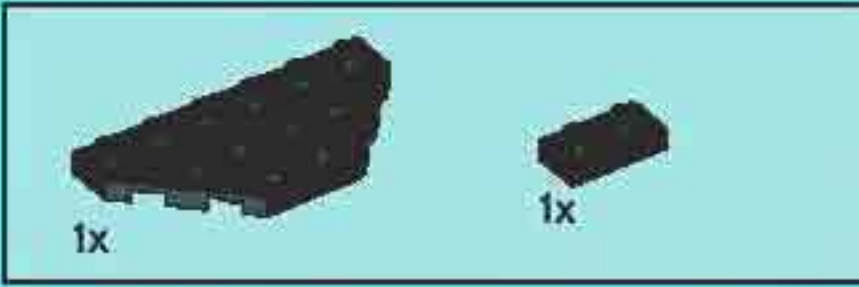

1

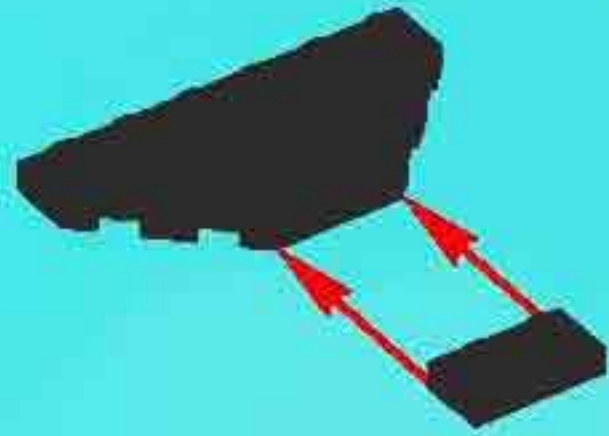

2

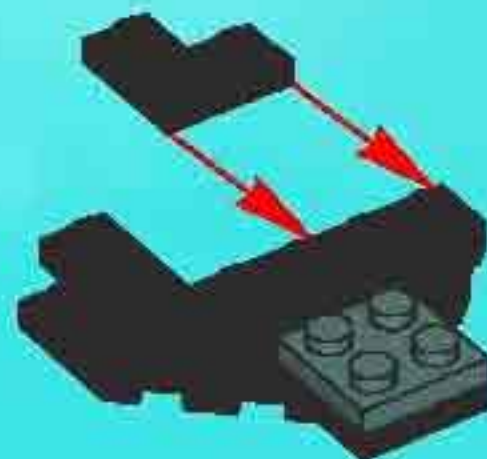







8

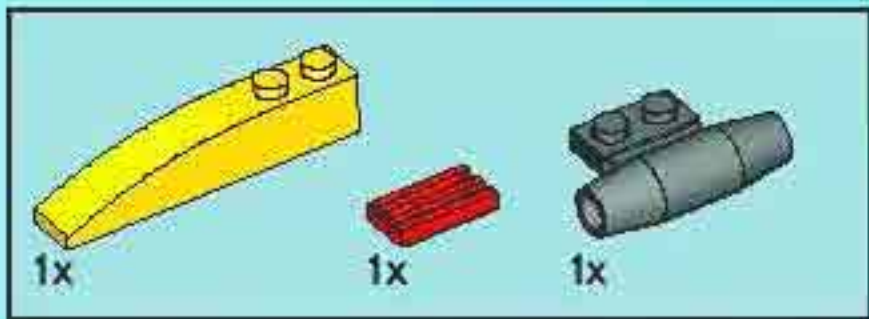
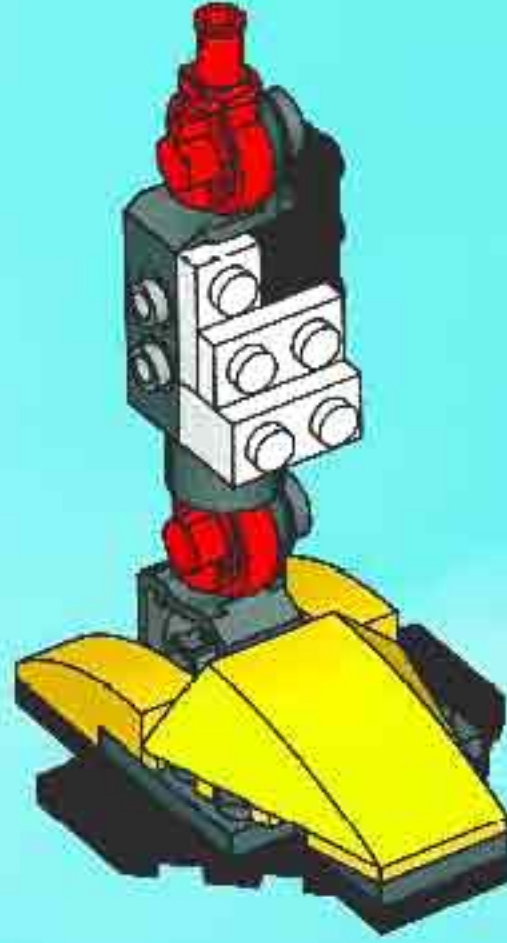

9

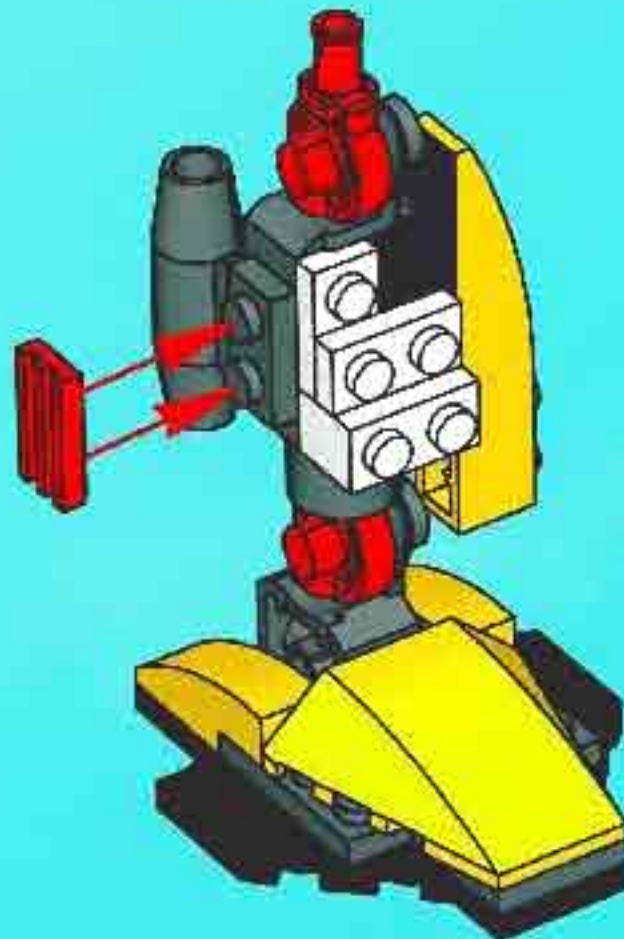

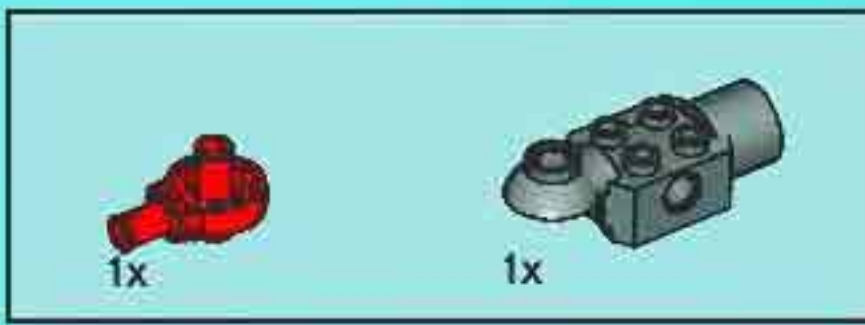

10

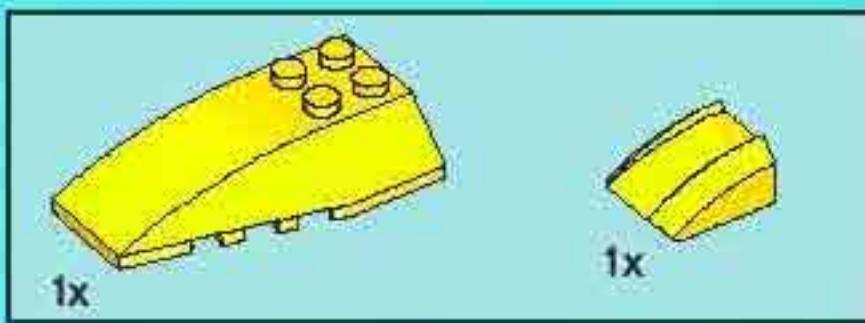
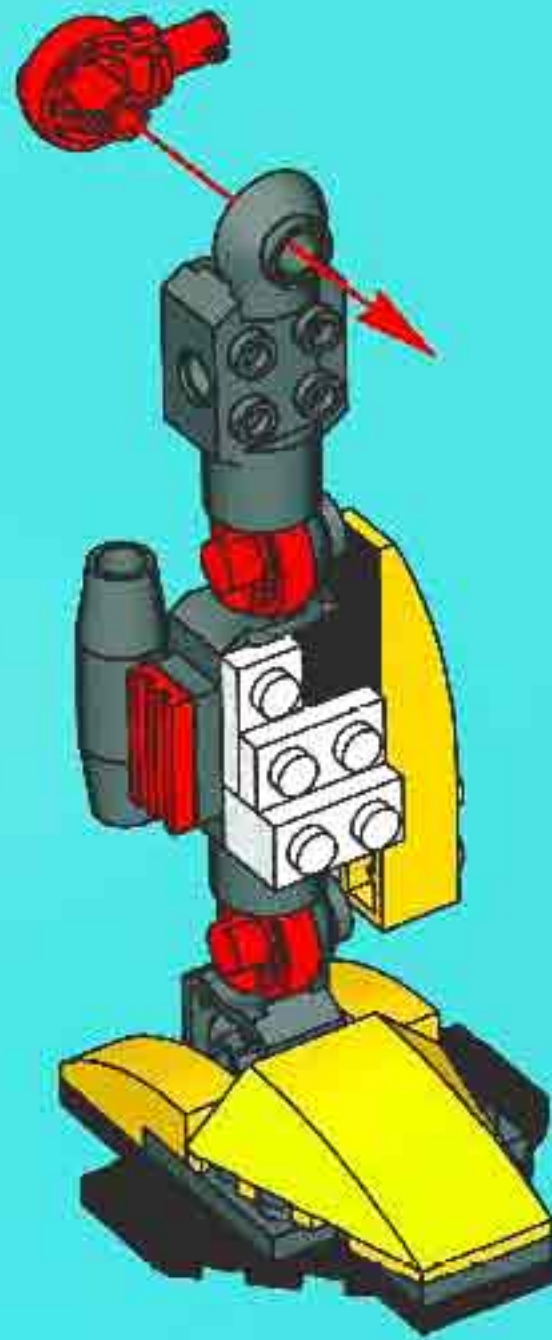

11



12

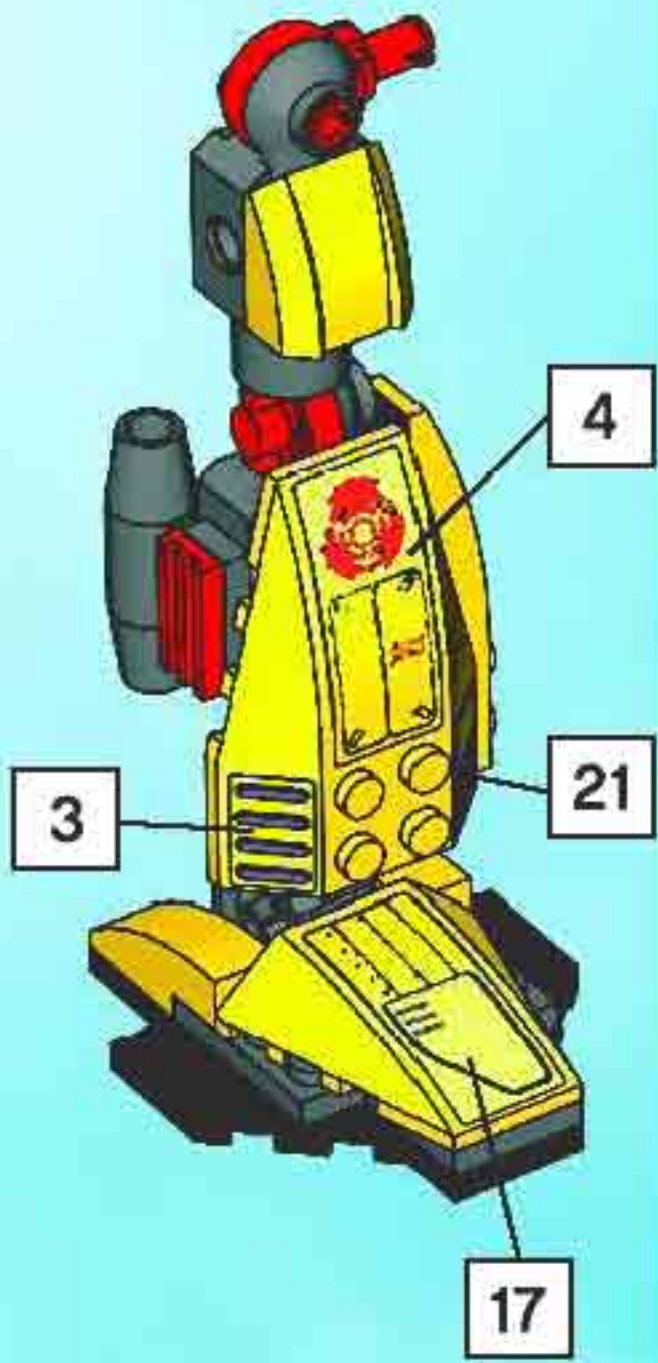

17

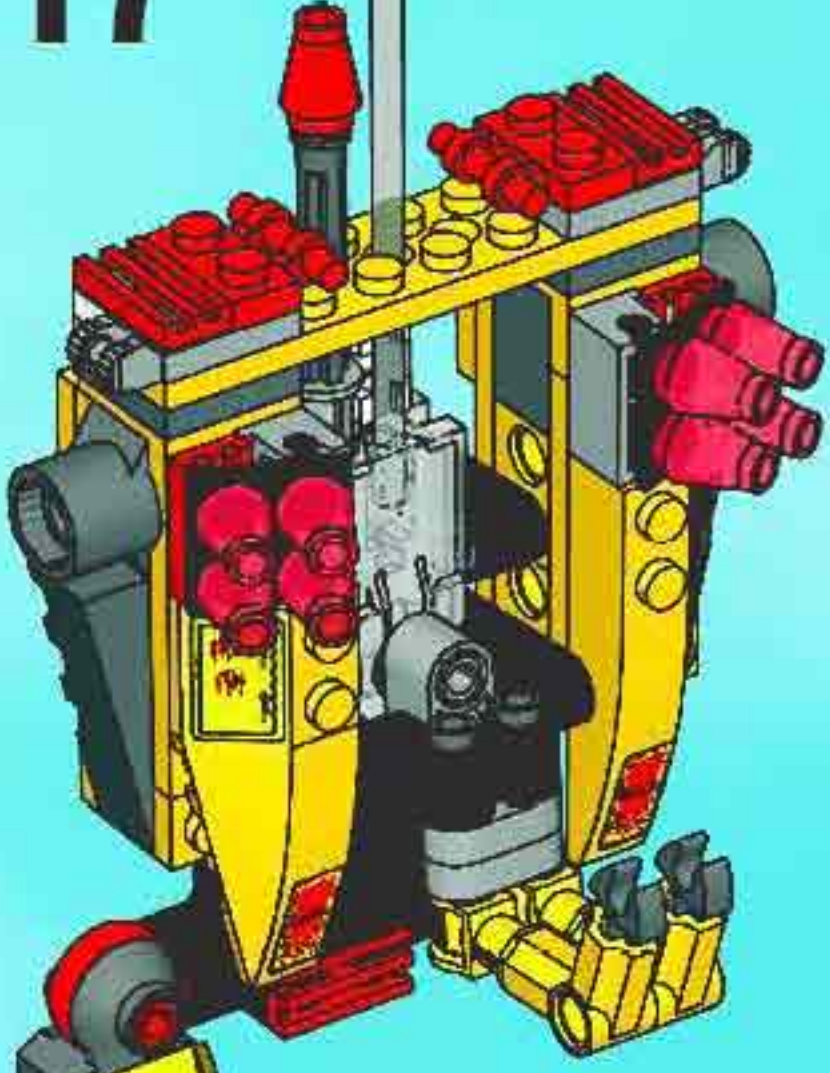

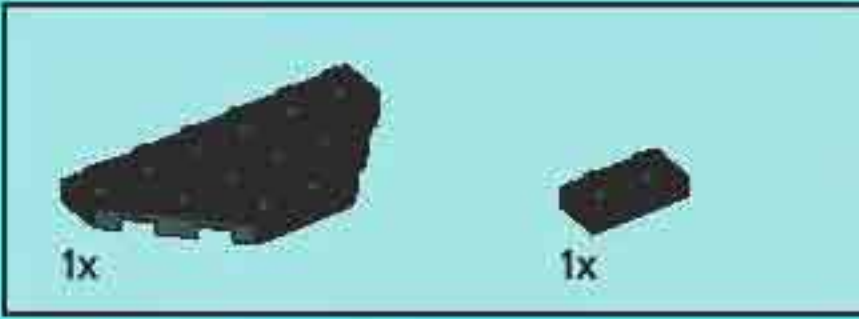

1

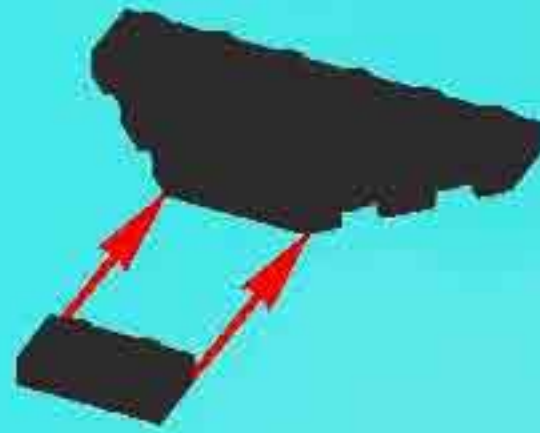

2

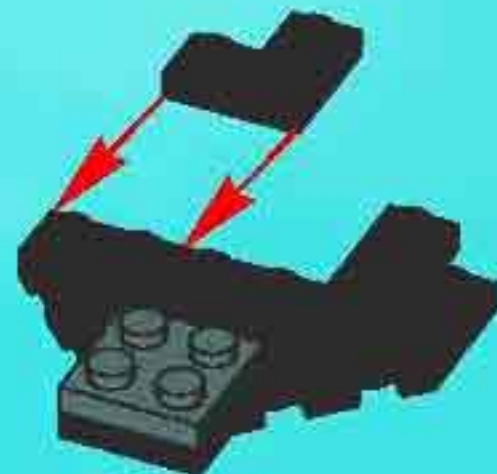

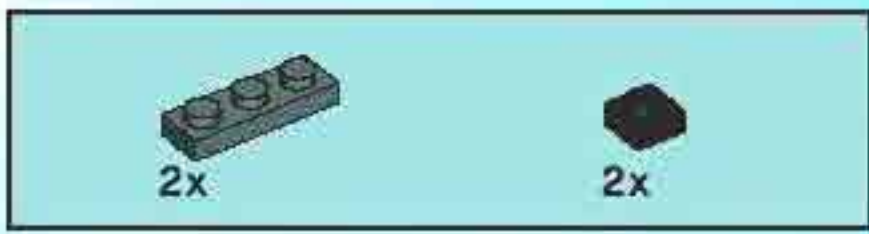

3

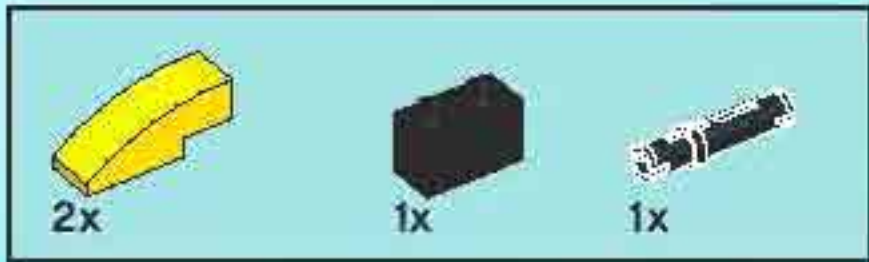
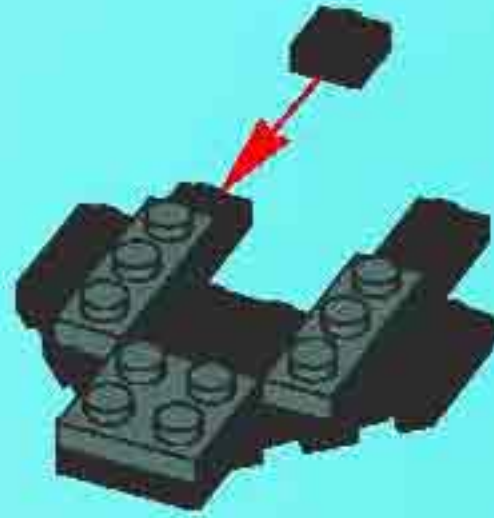

4

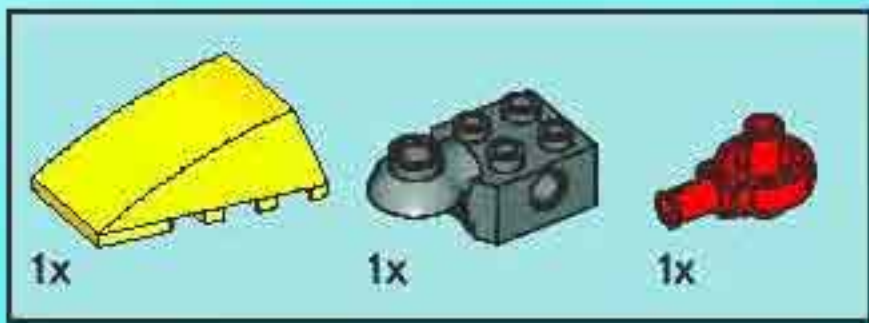

5

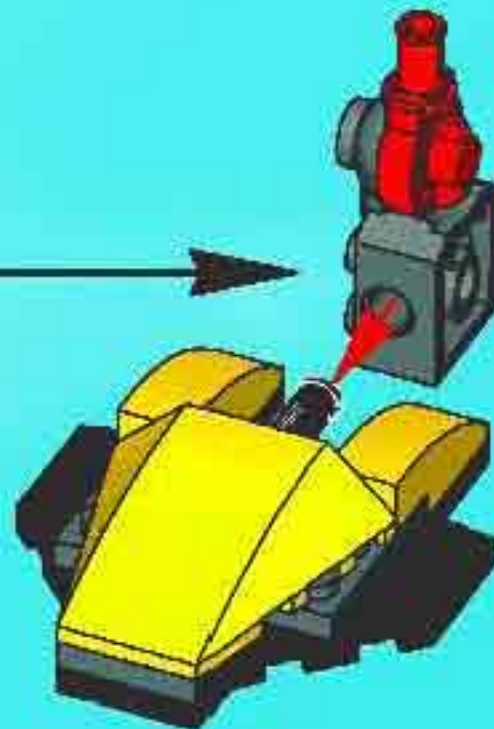
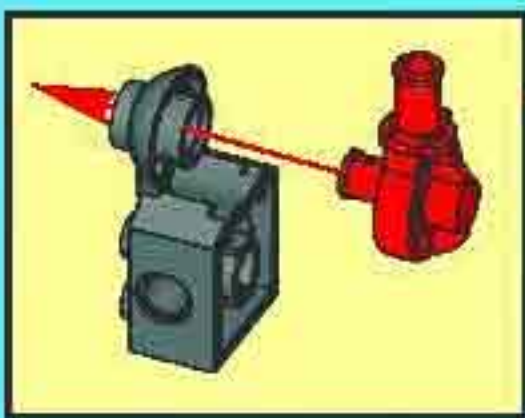

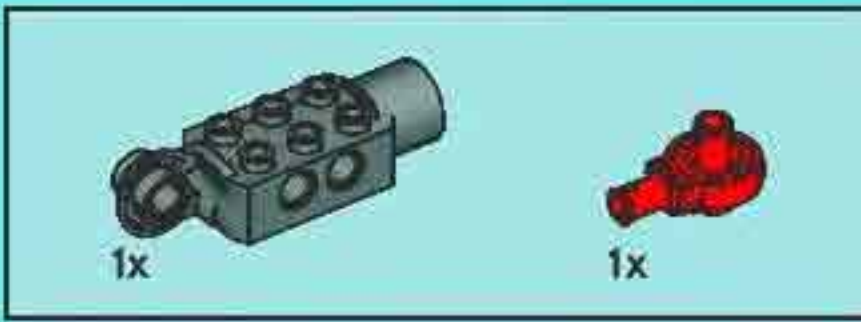

6

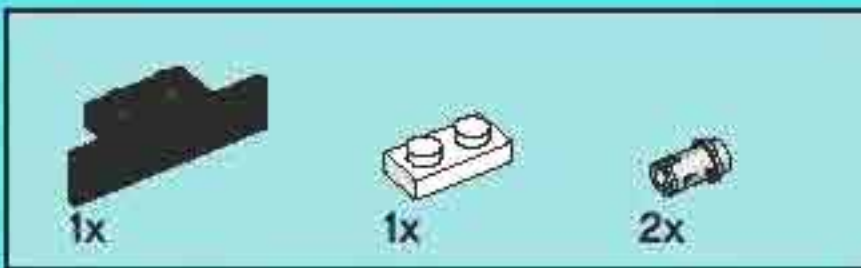
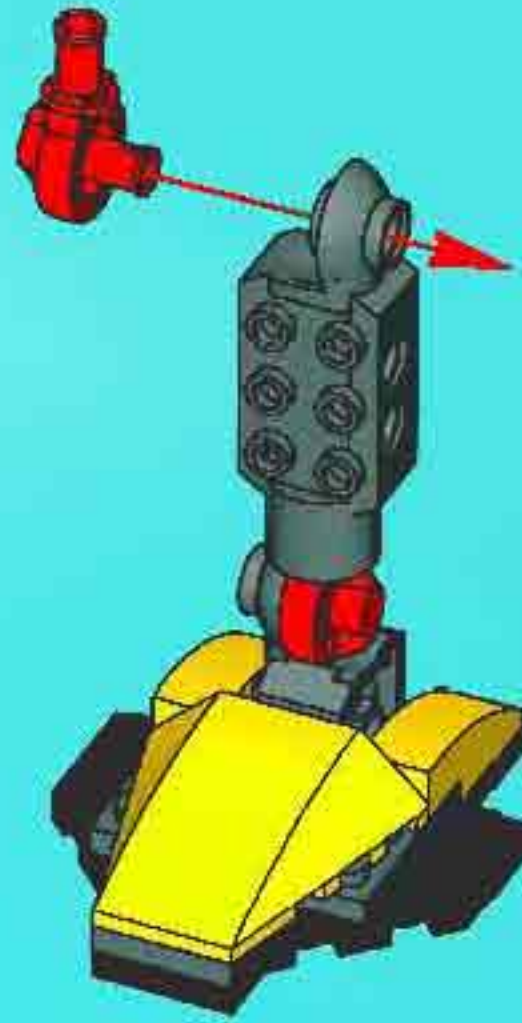

7

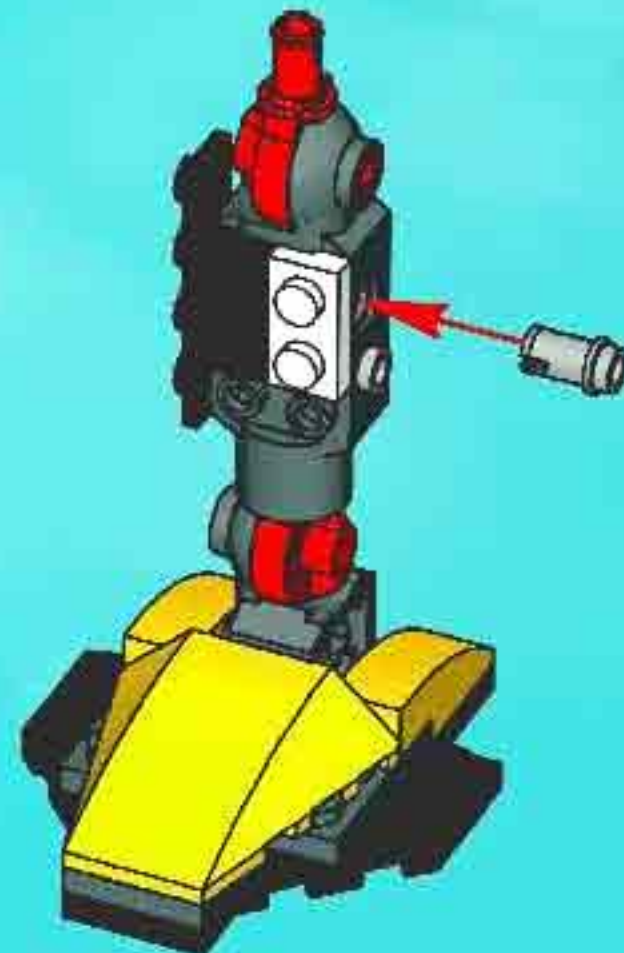



8

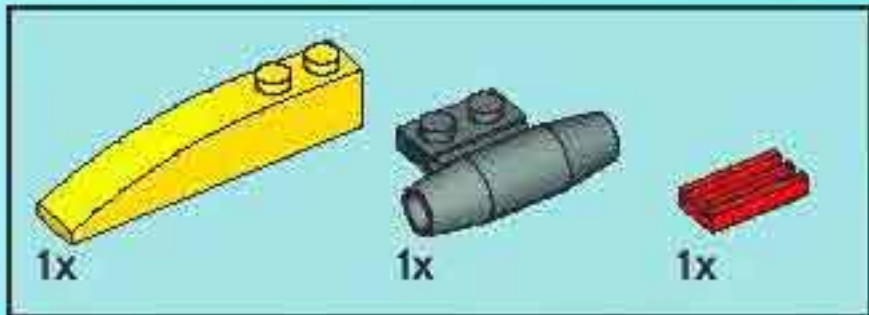
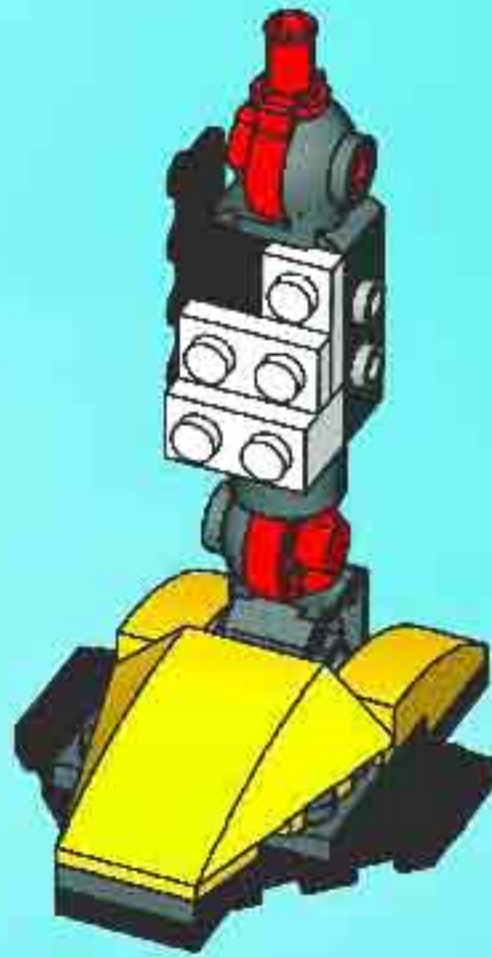

9

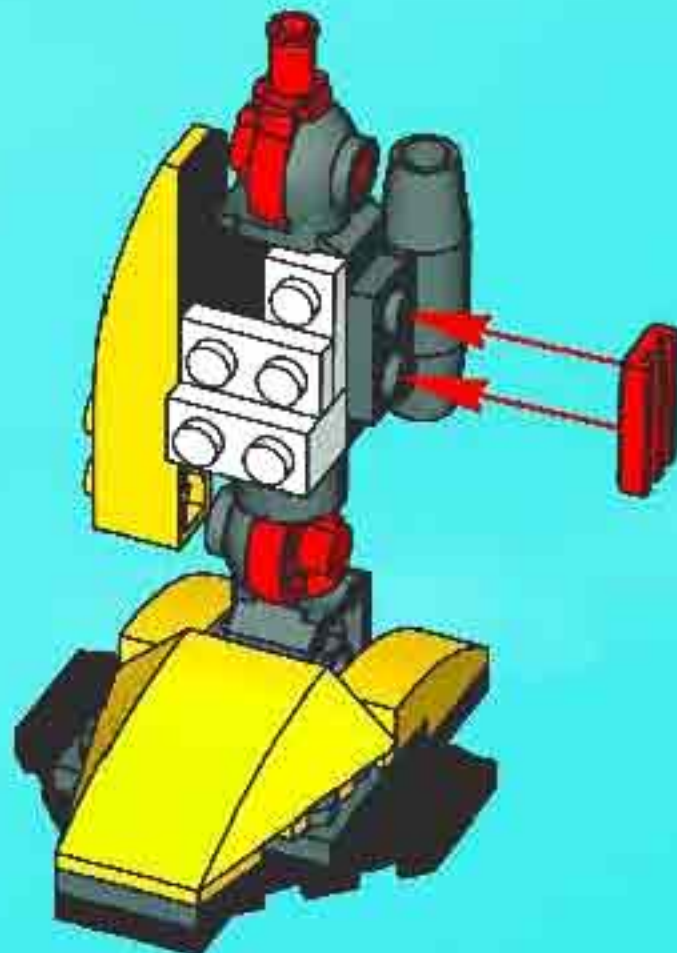



10

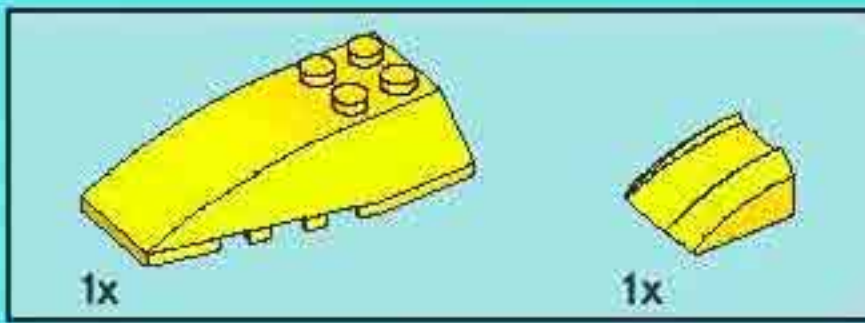
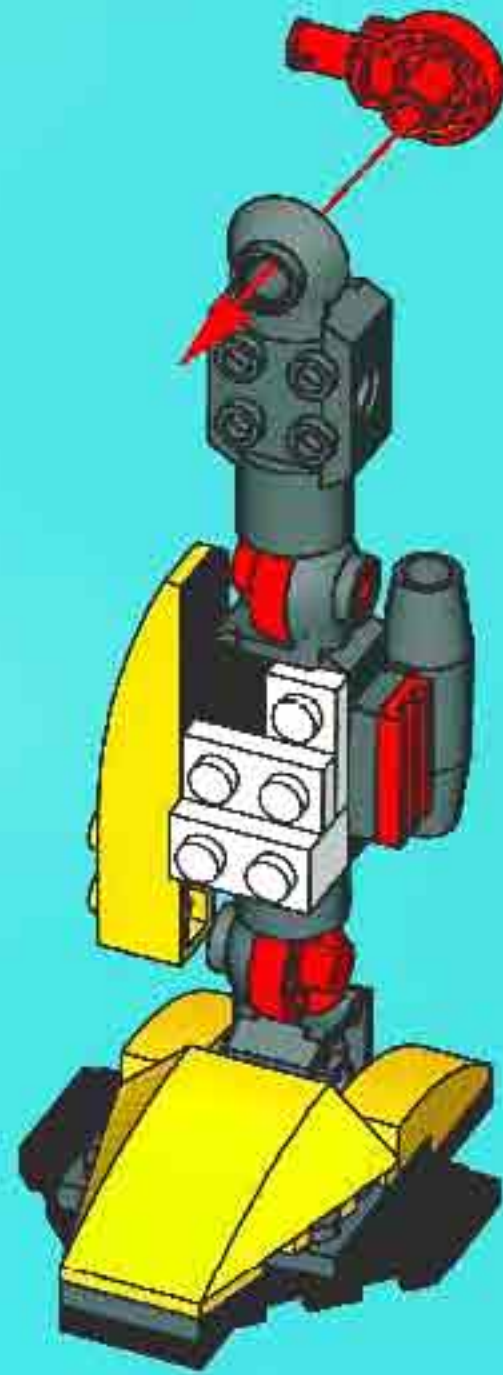

11

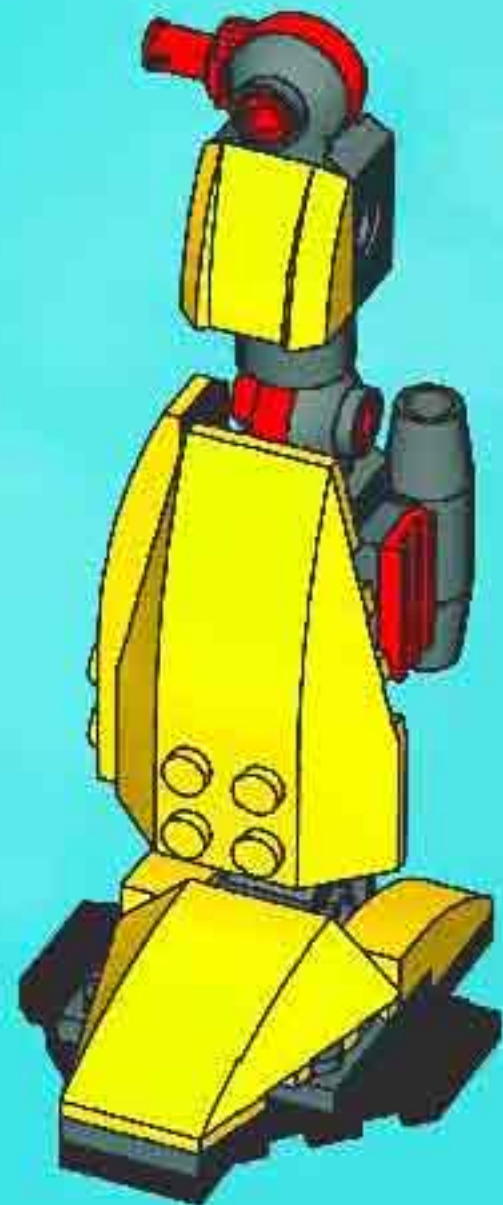

12

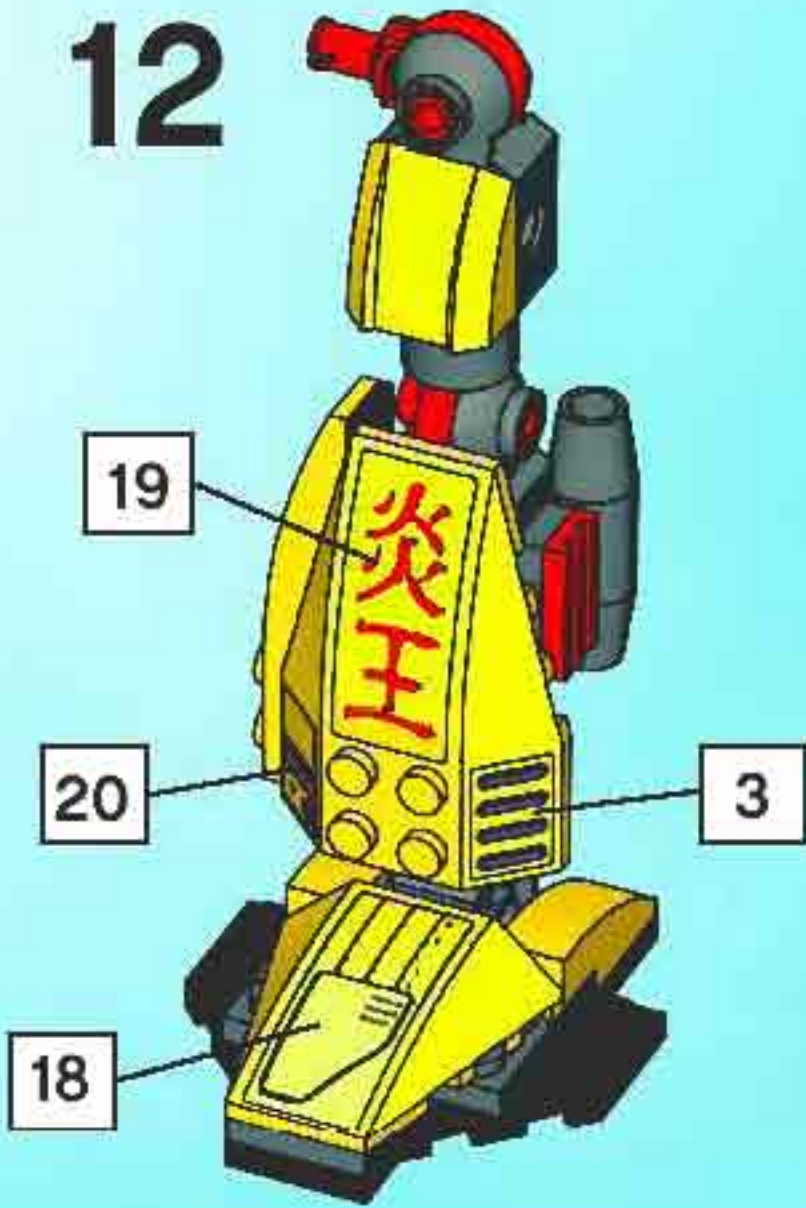

18

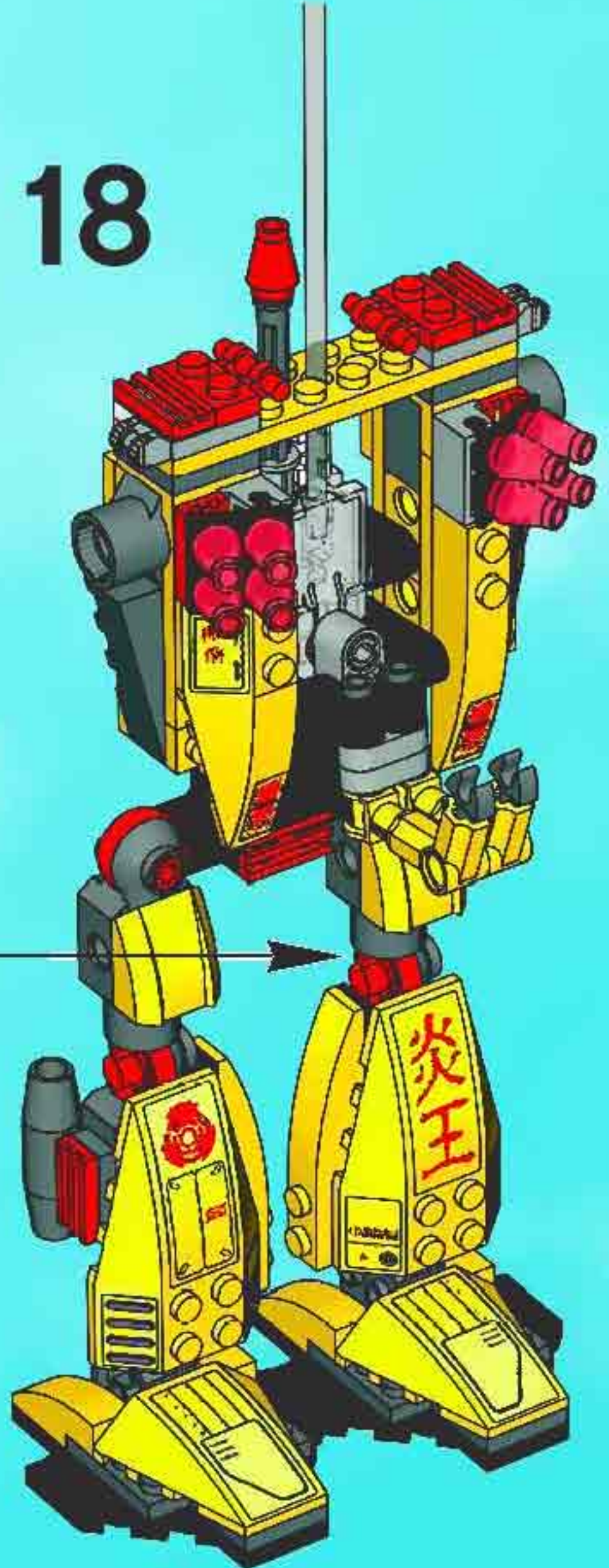

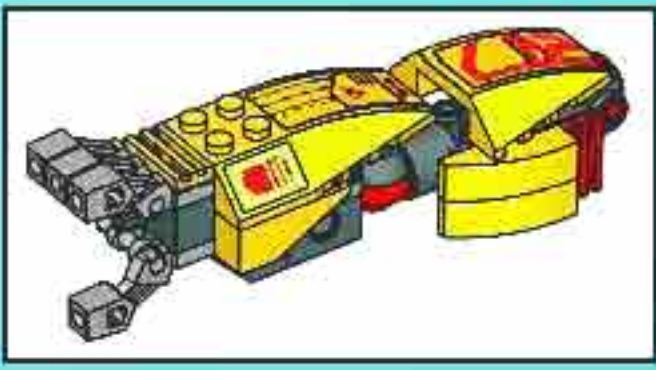

1

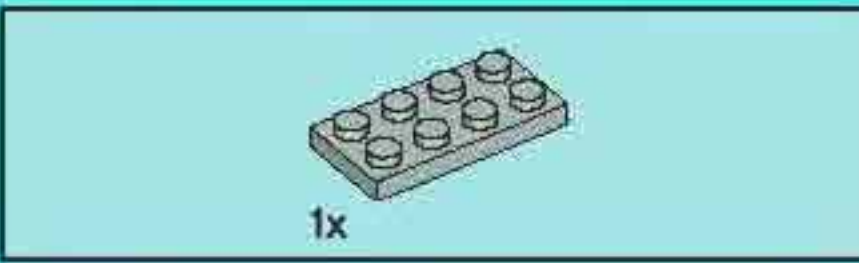
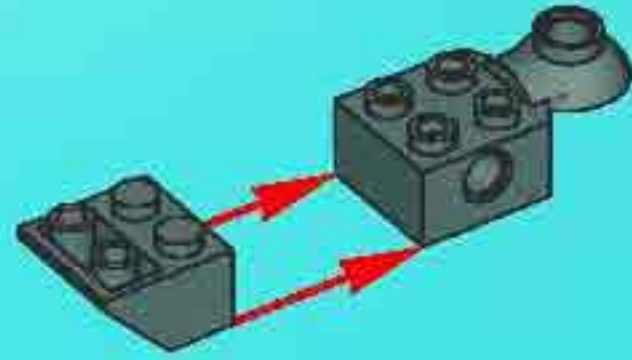

2



3

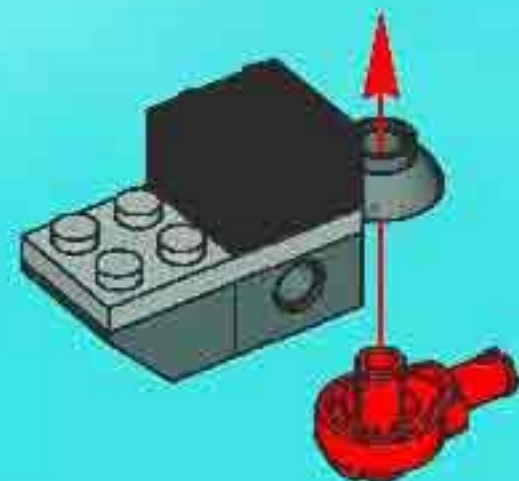



4

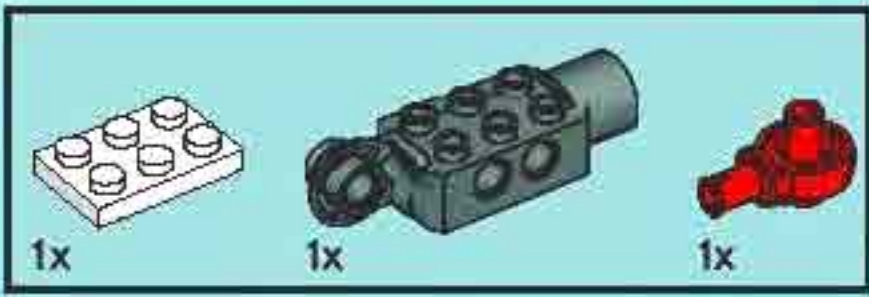
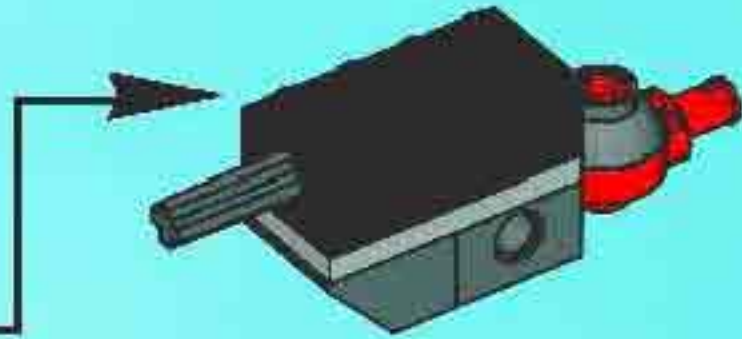
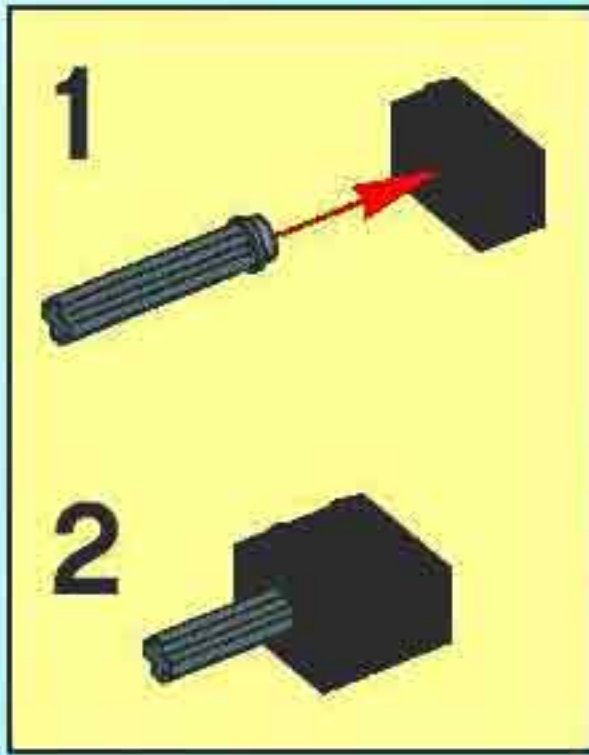

5

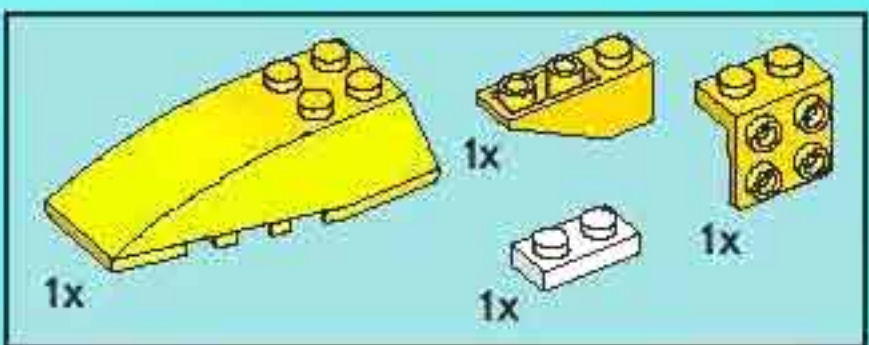
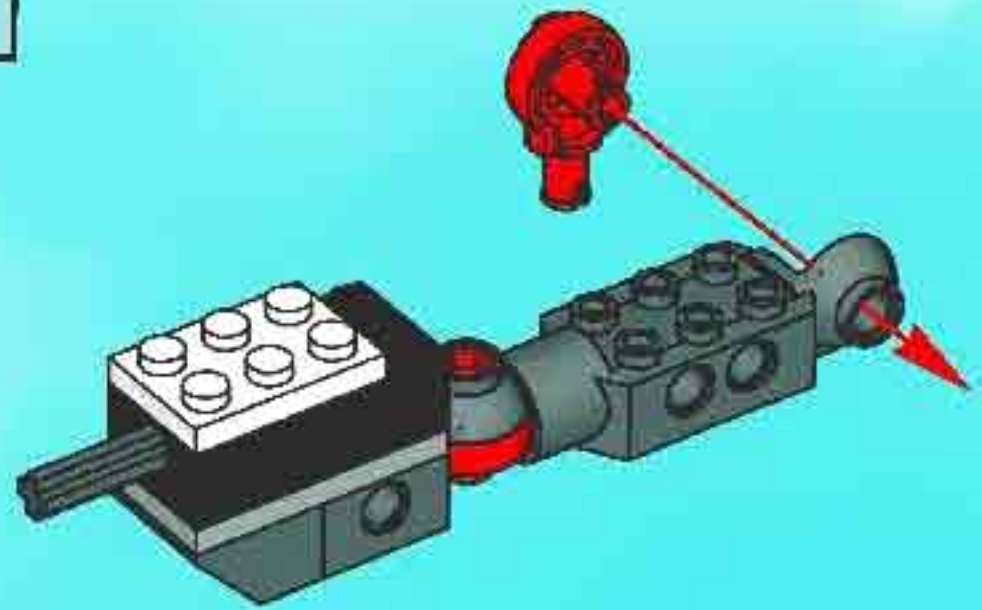

6

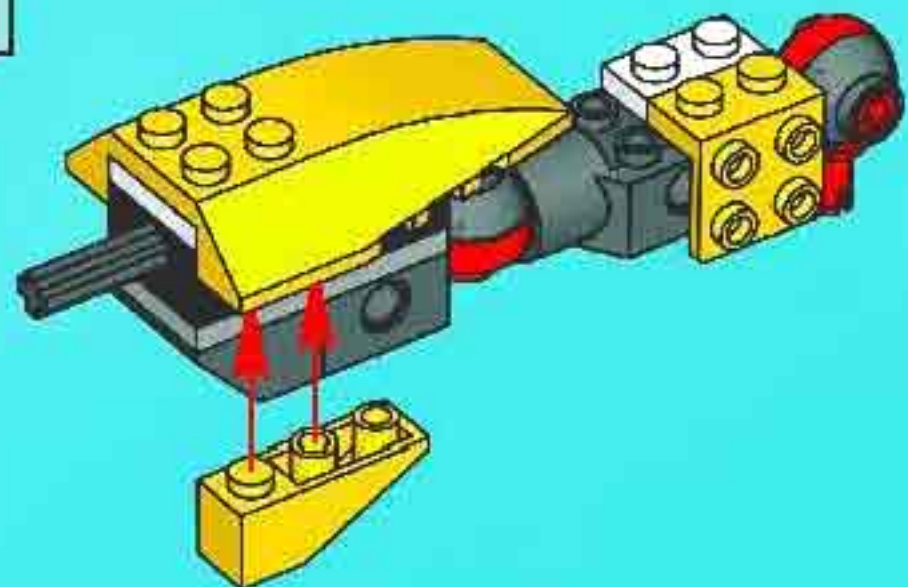



7

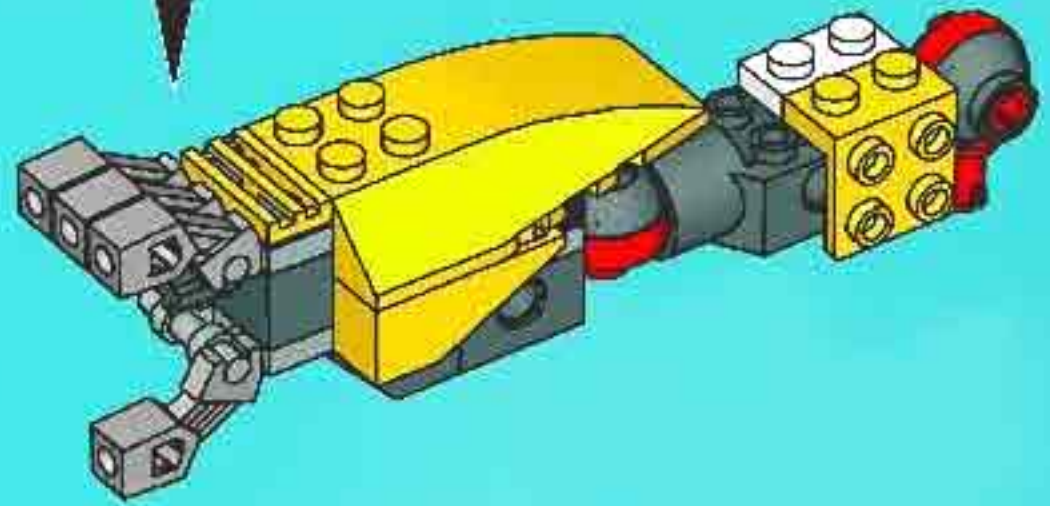
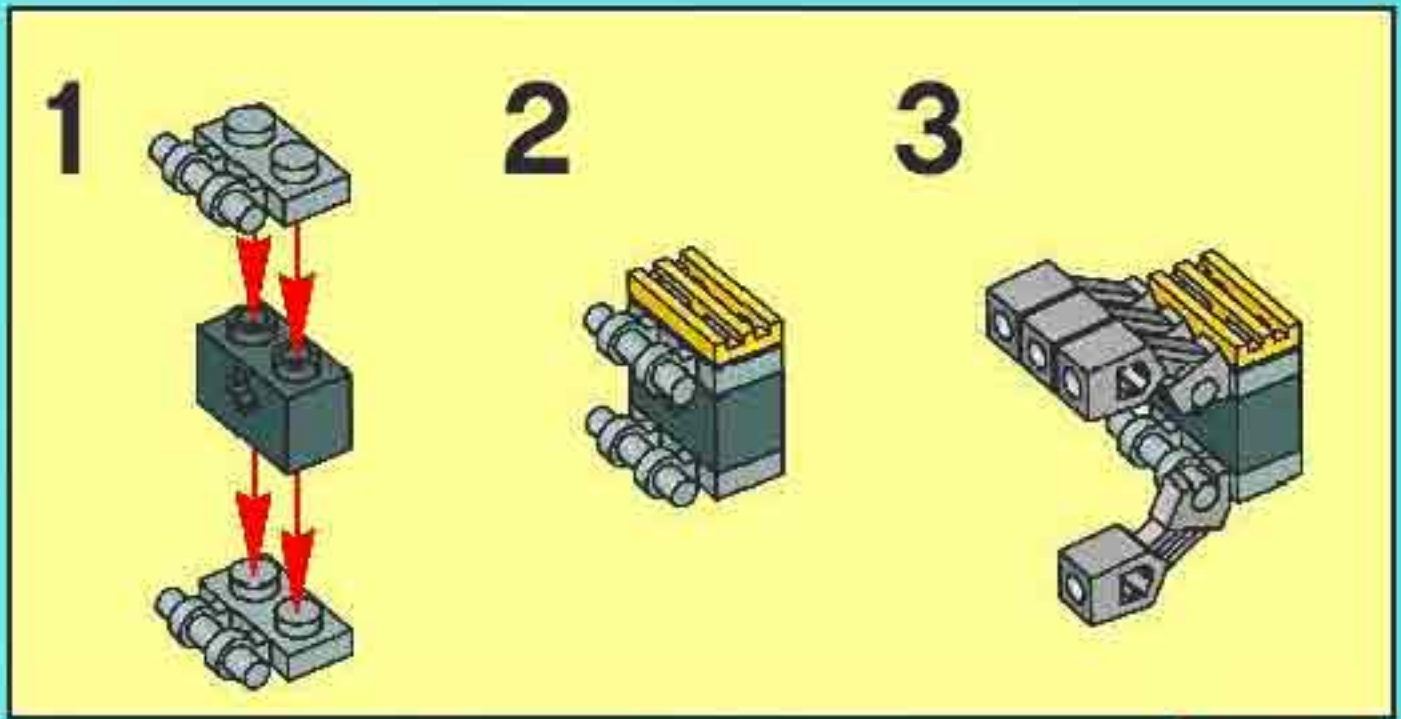

8

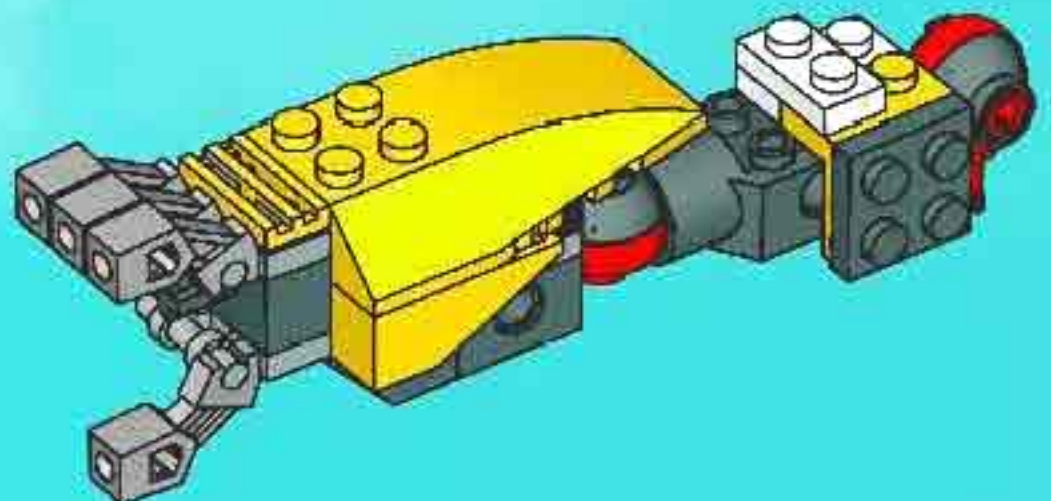

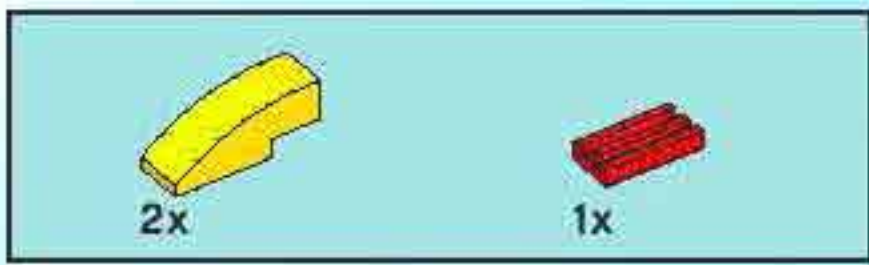

9

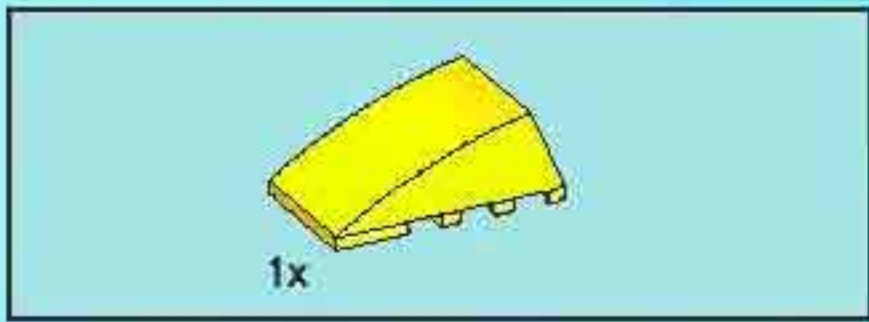
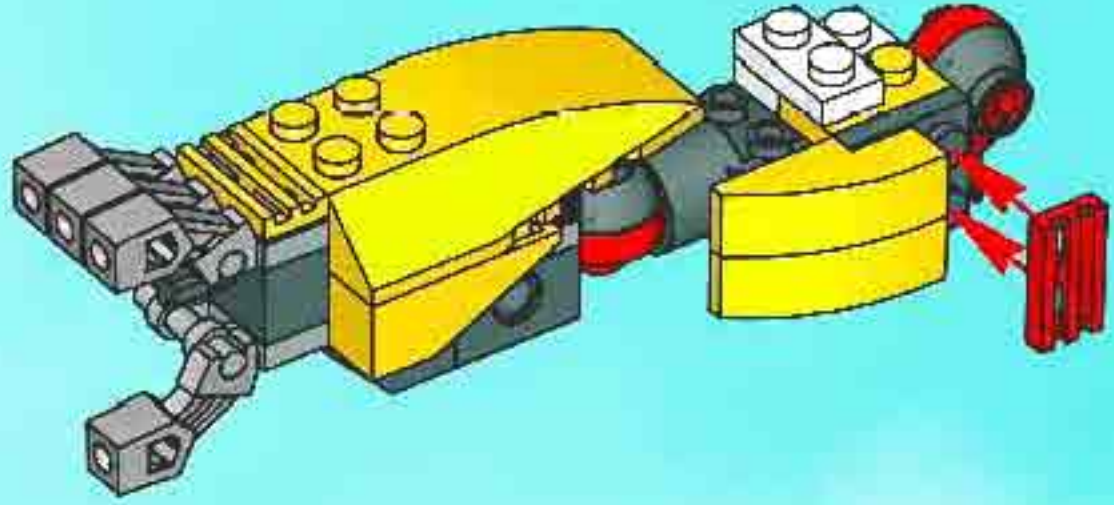

10

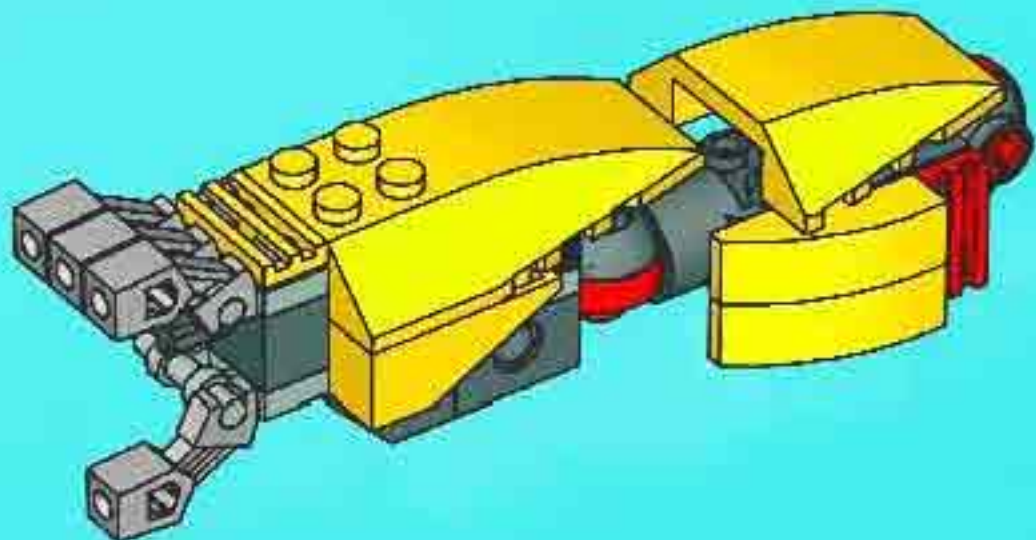

11

16

14

11

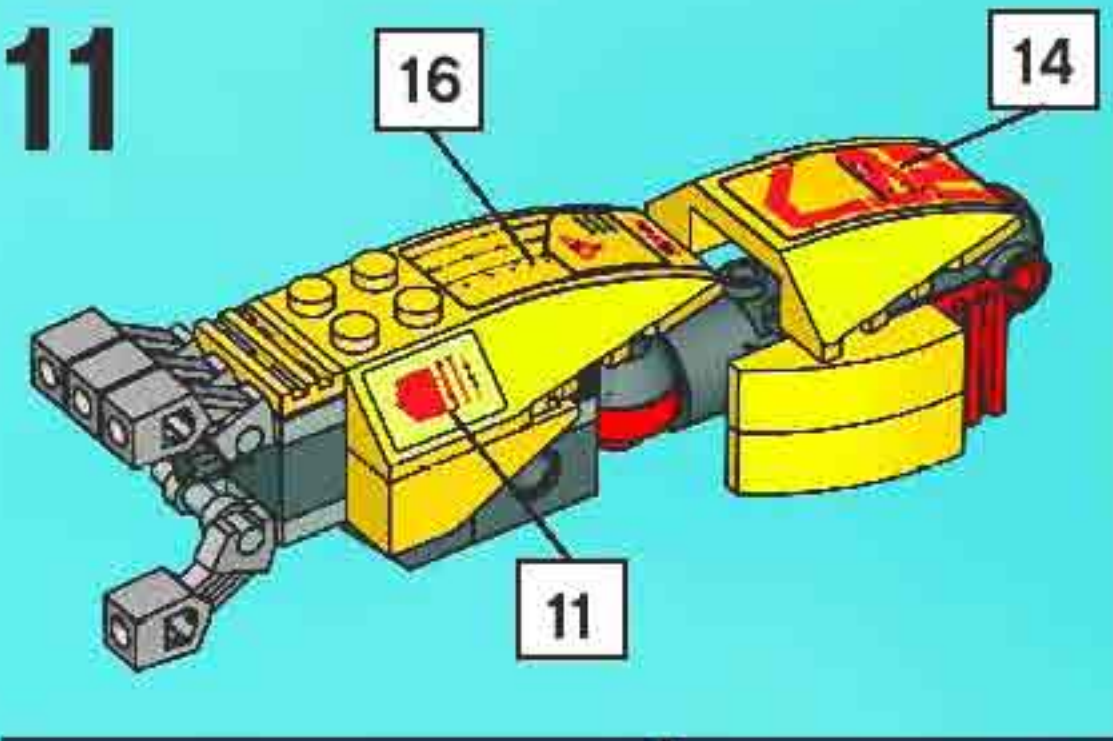

19

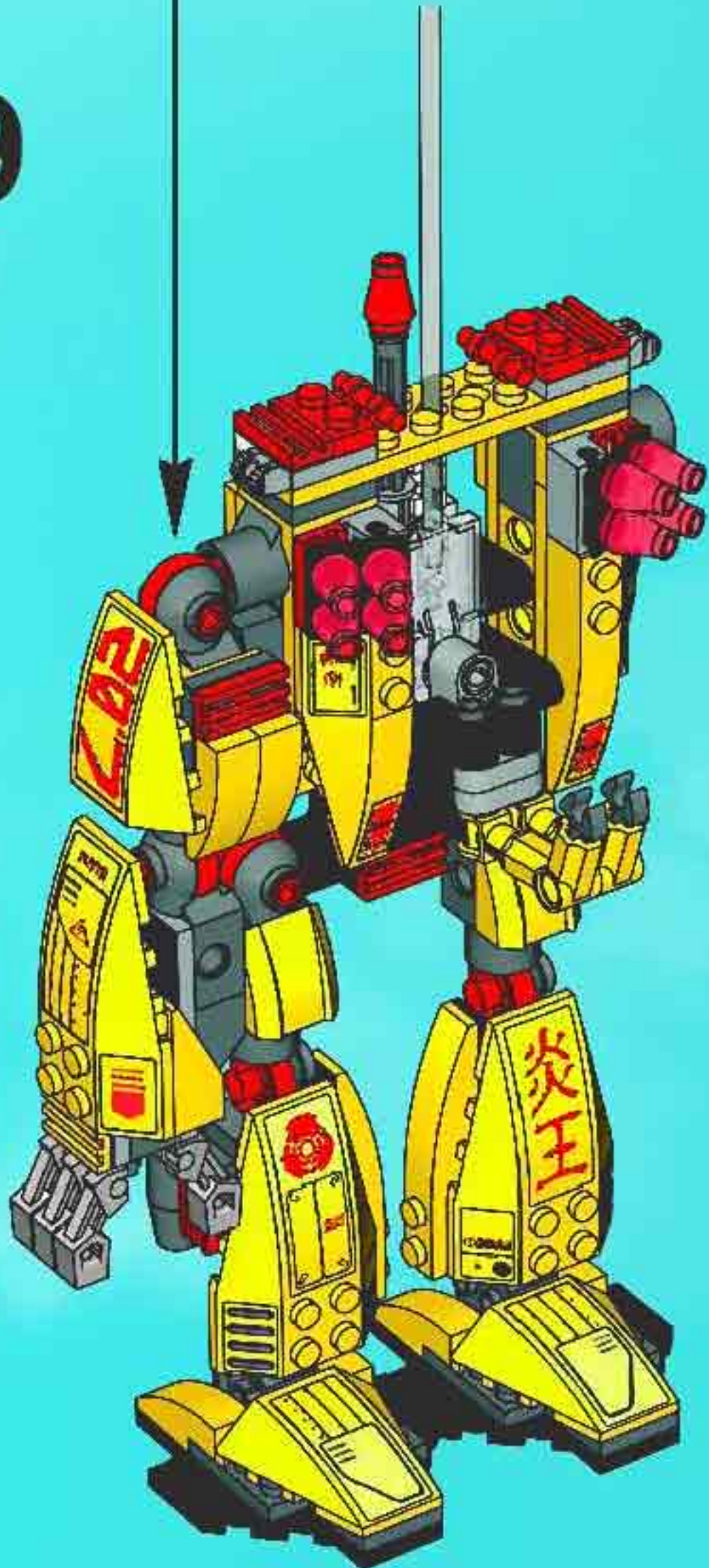

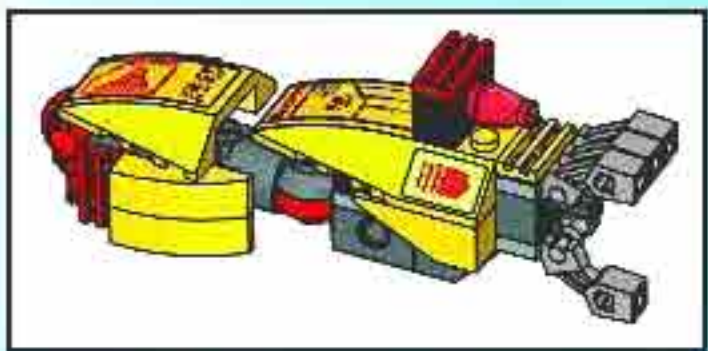

1

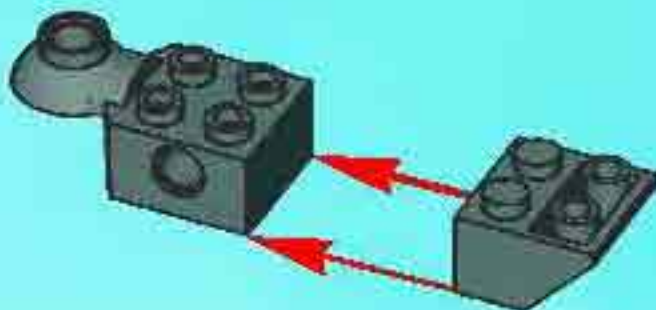

2



3

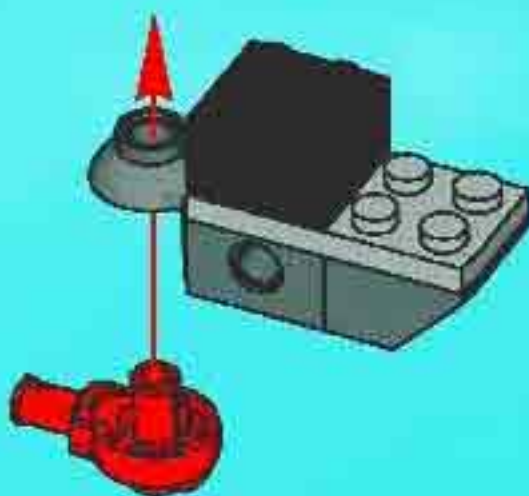

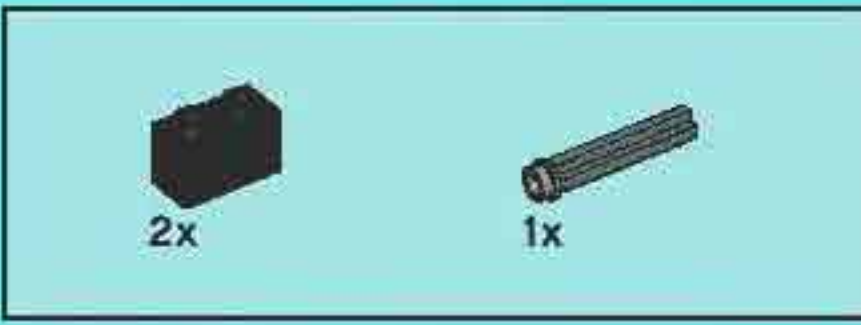

4

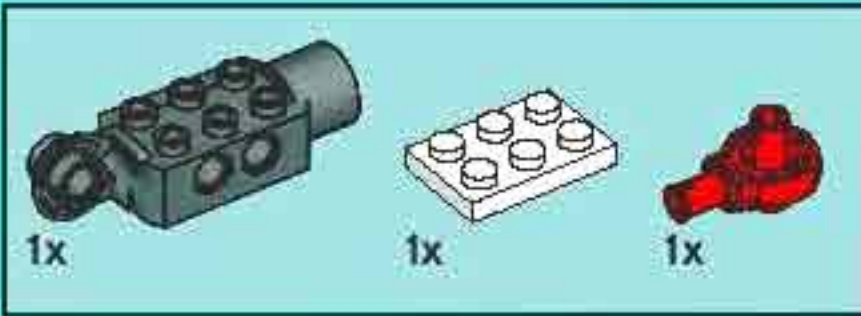
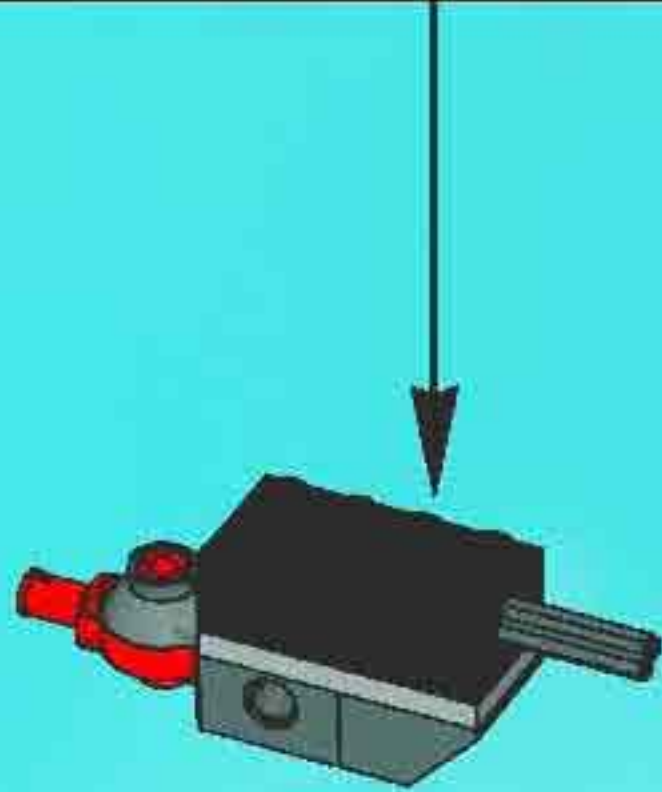

5

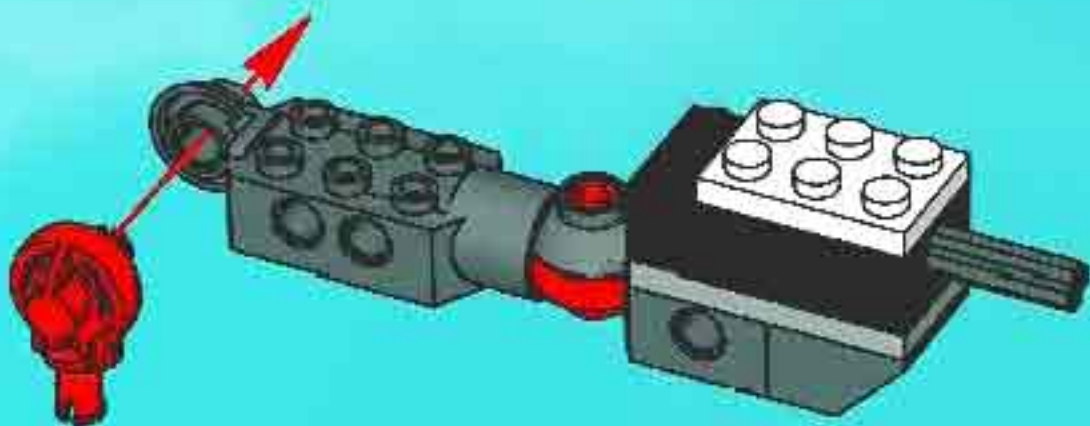

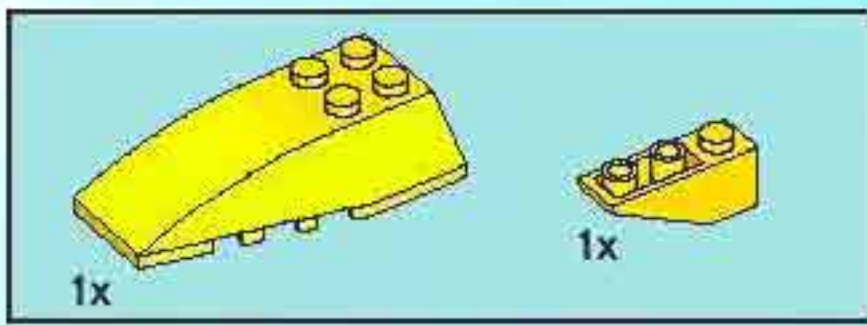

6

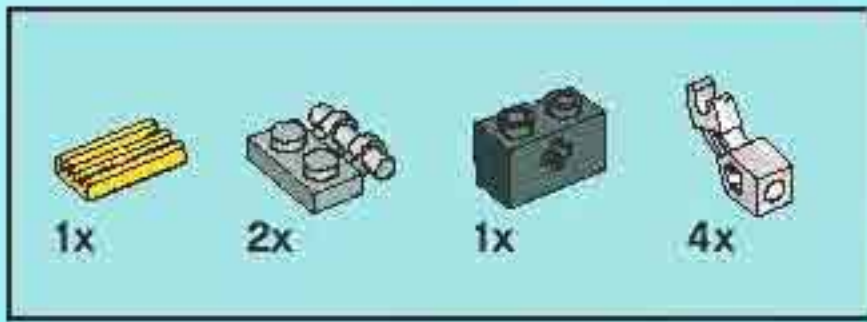
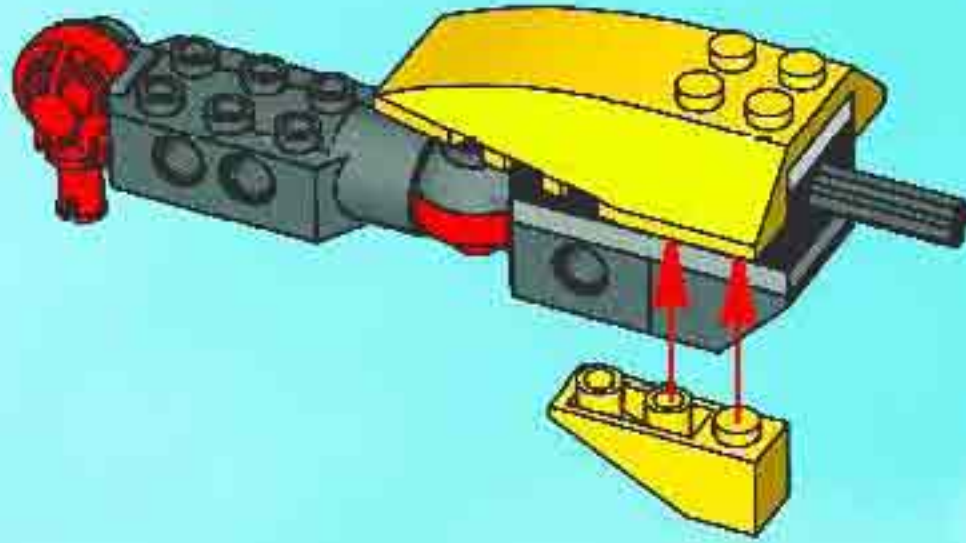

7

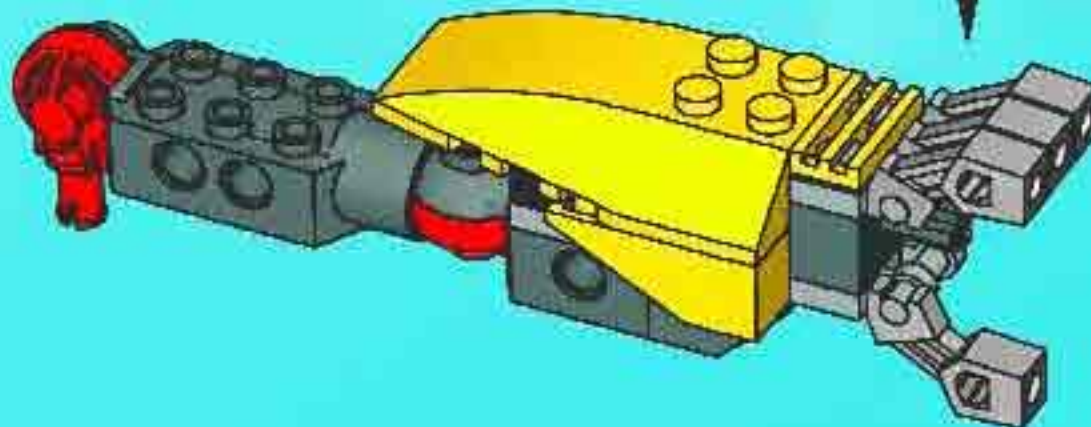
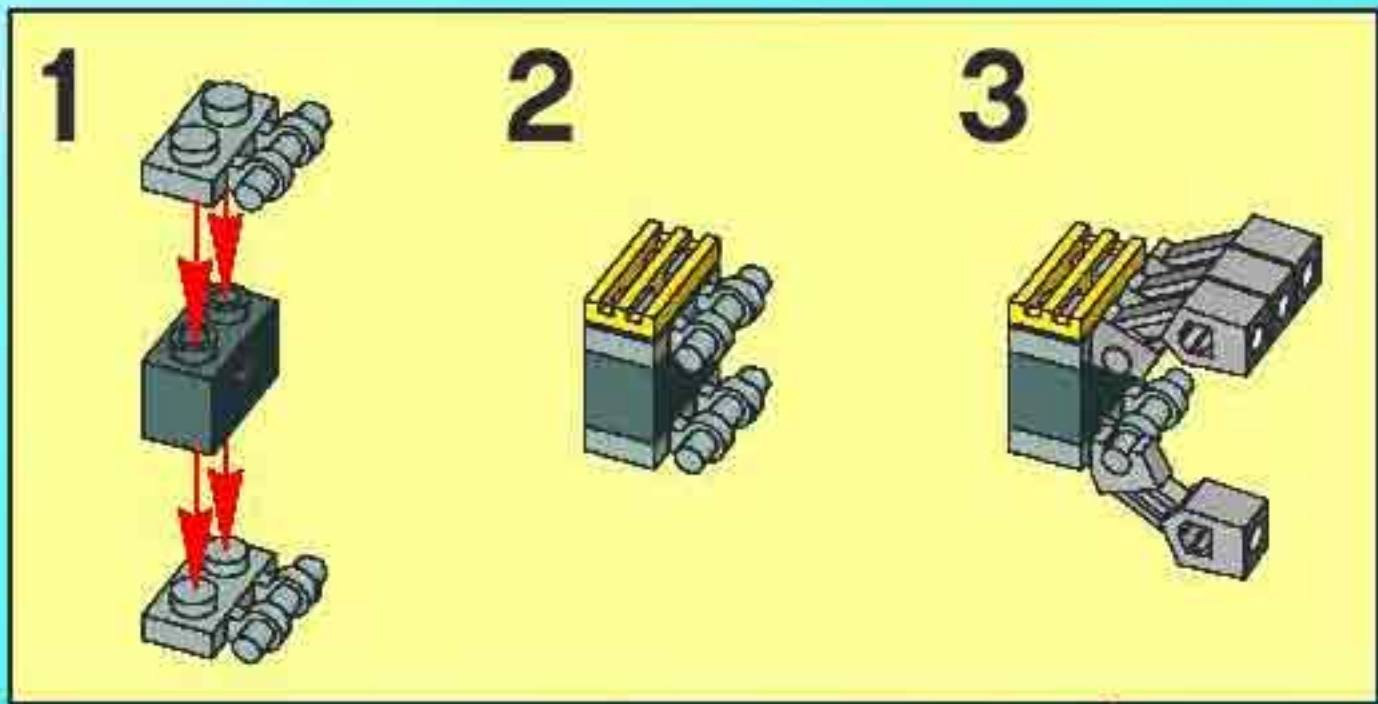

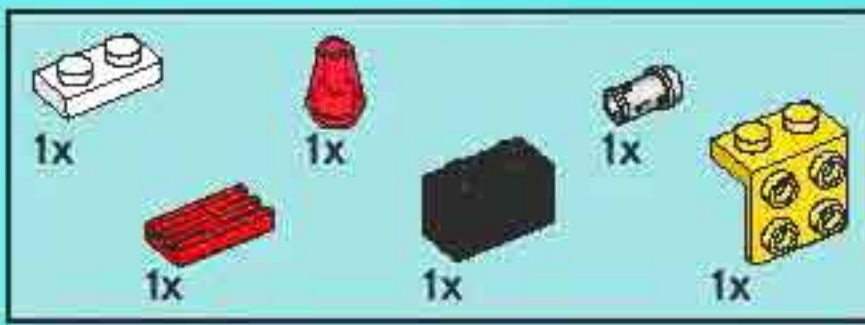

8

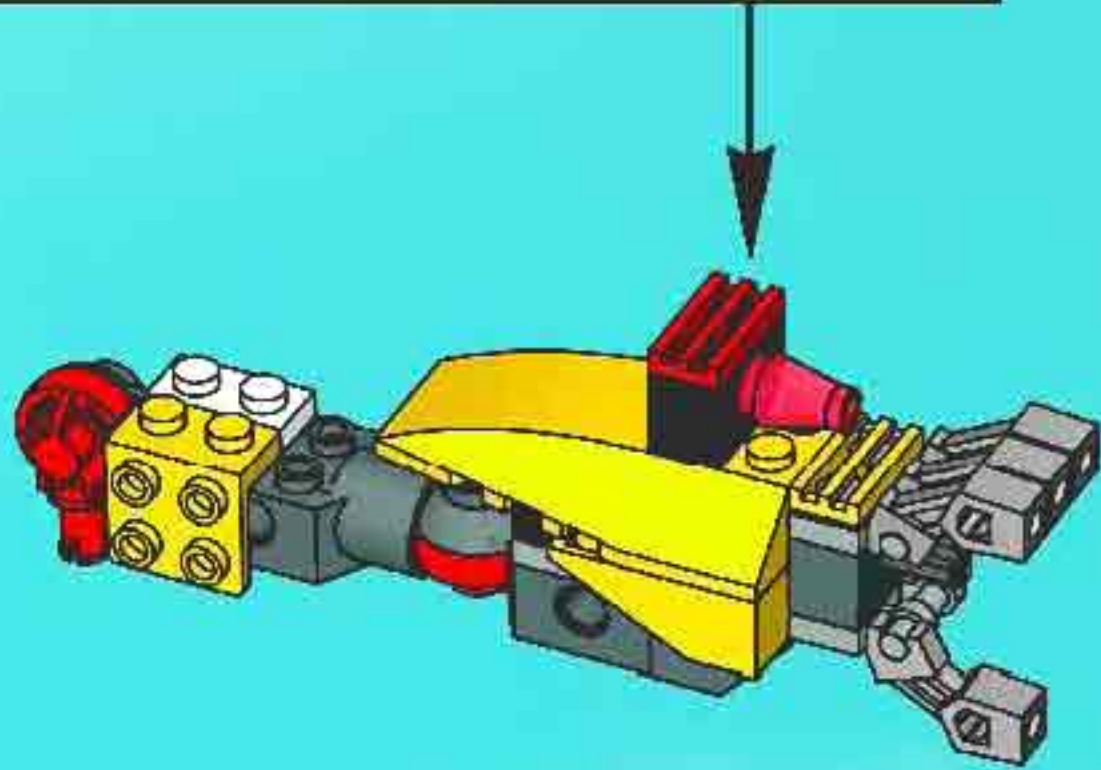
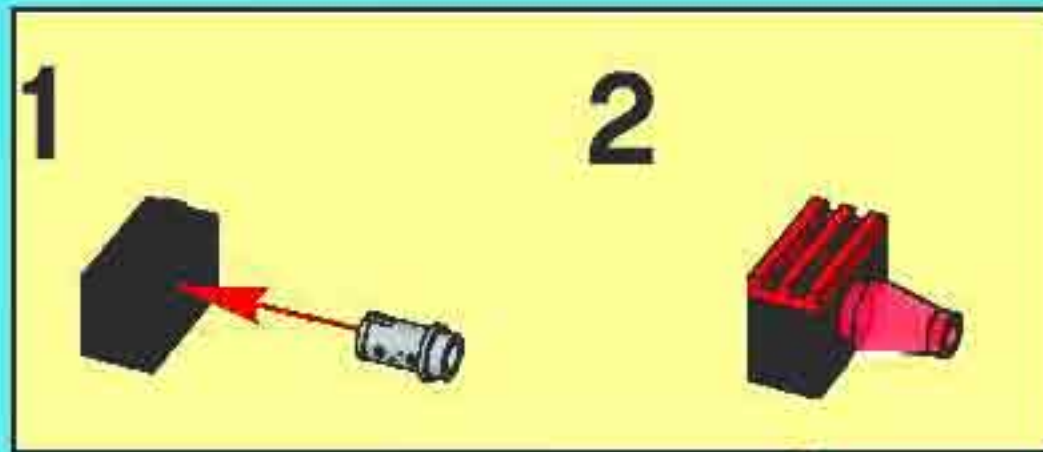

9

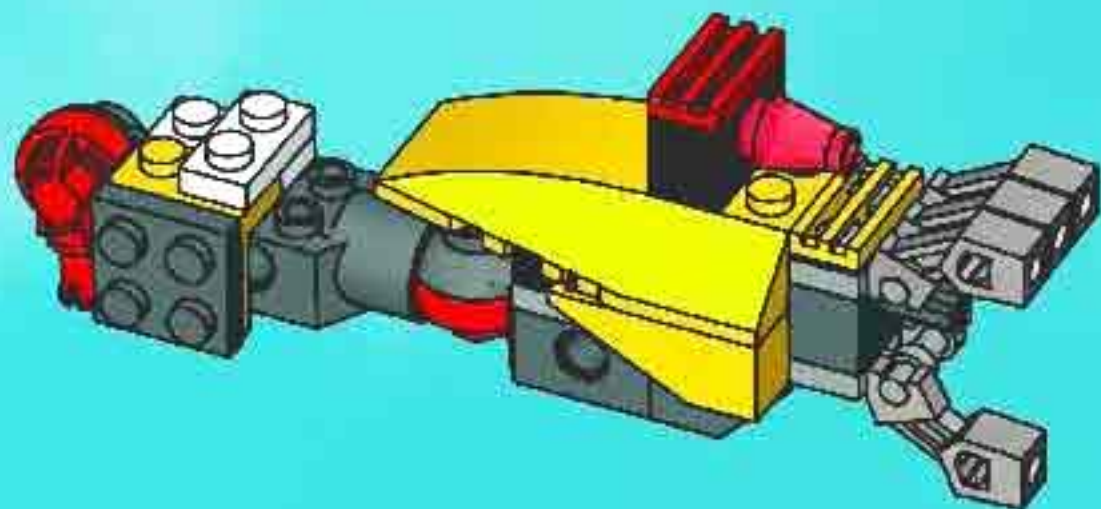



10

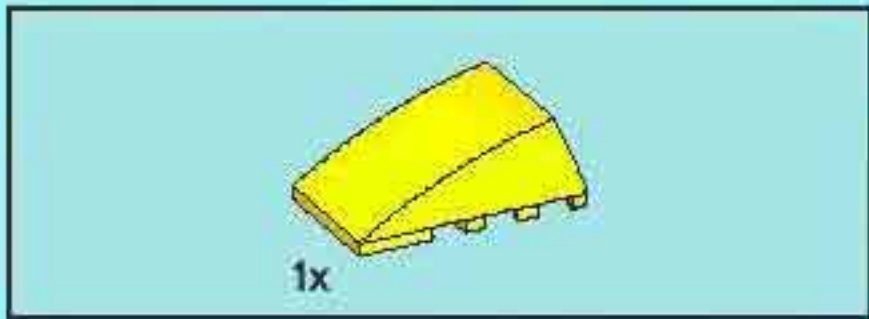
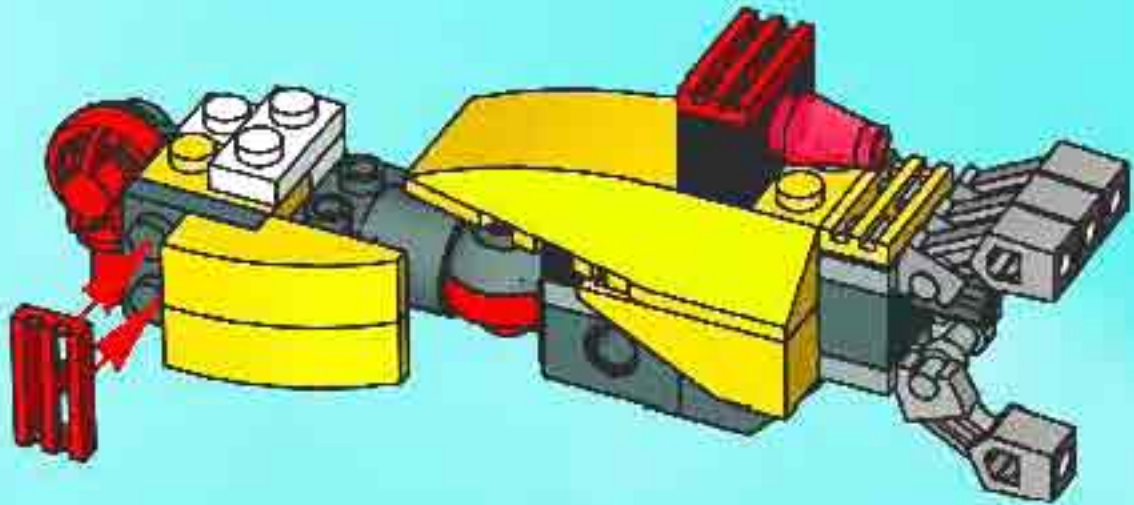

11

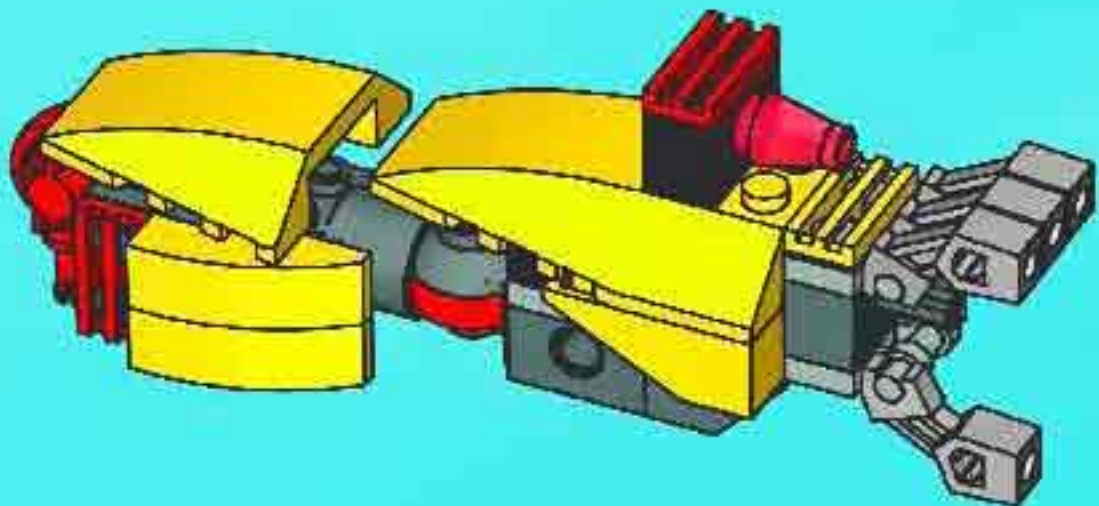

# 12

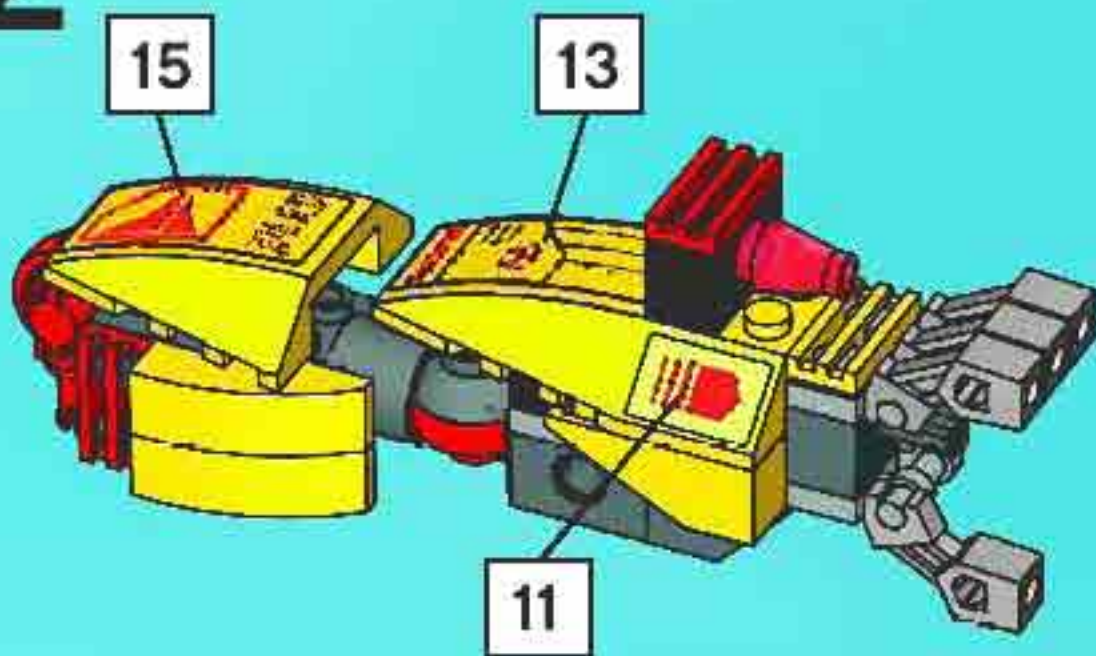

# 20

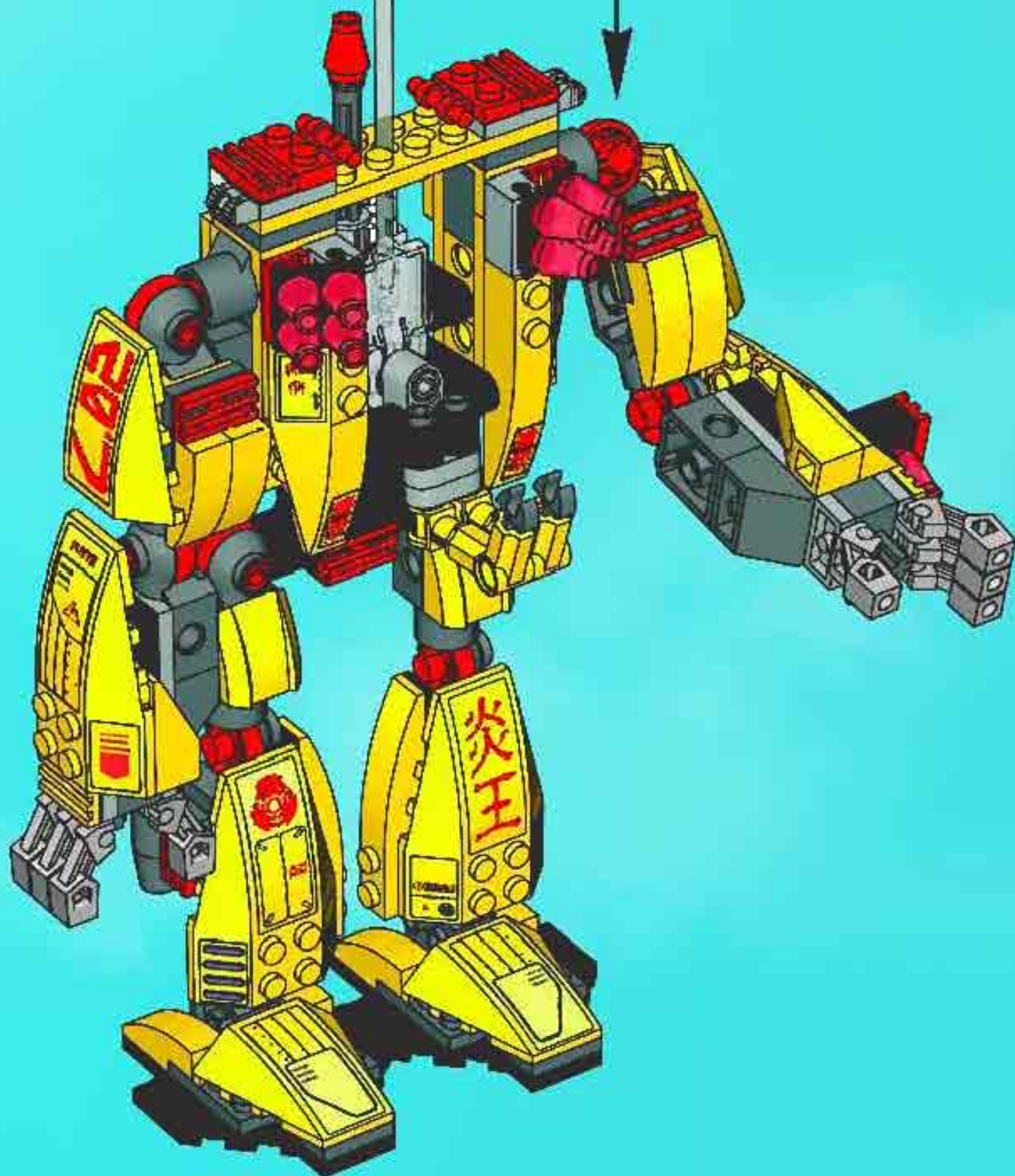

21

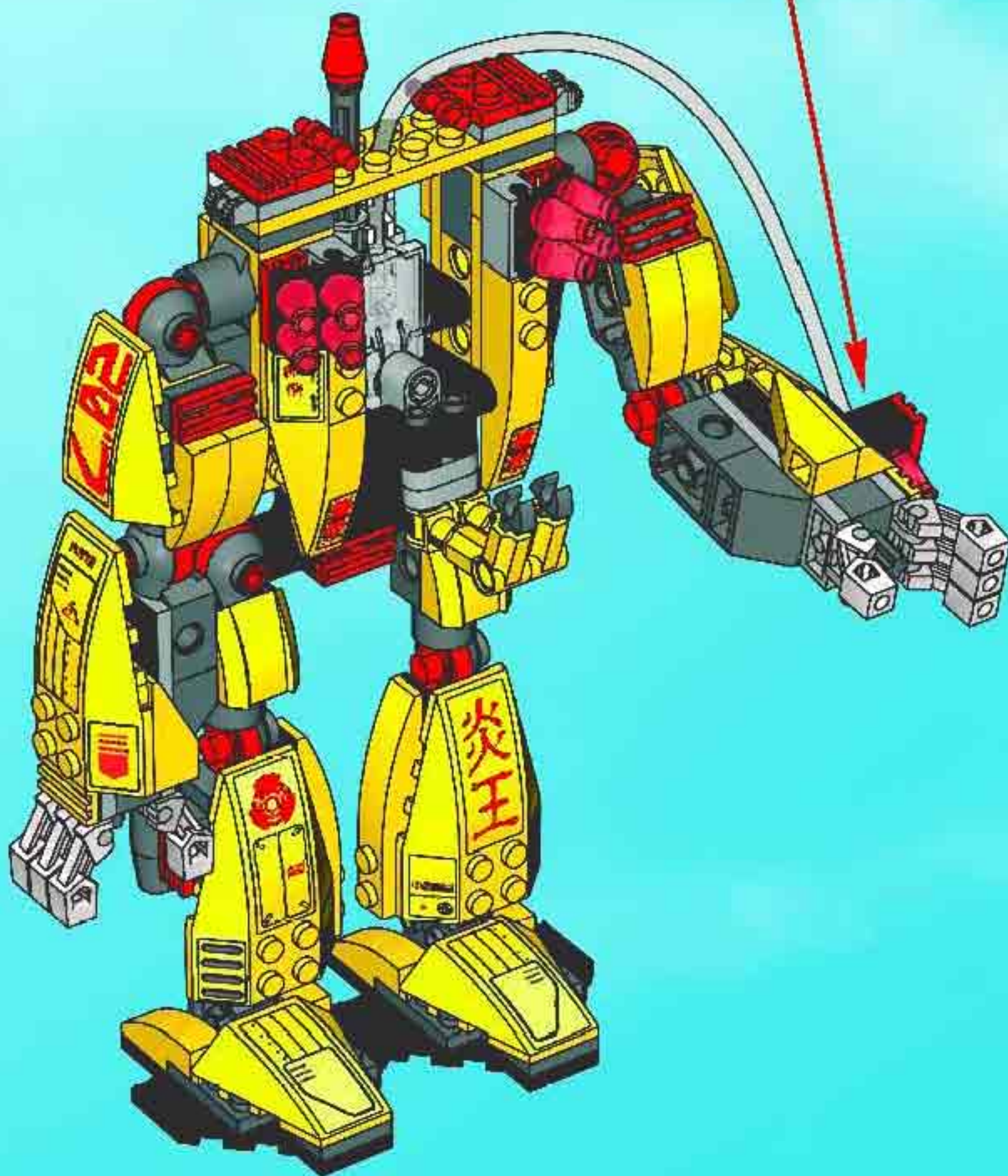
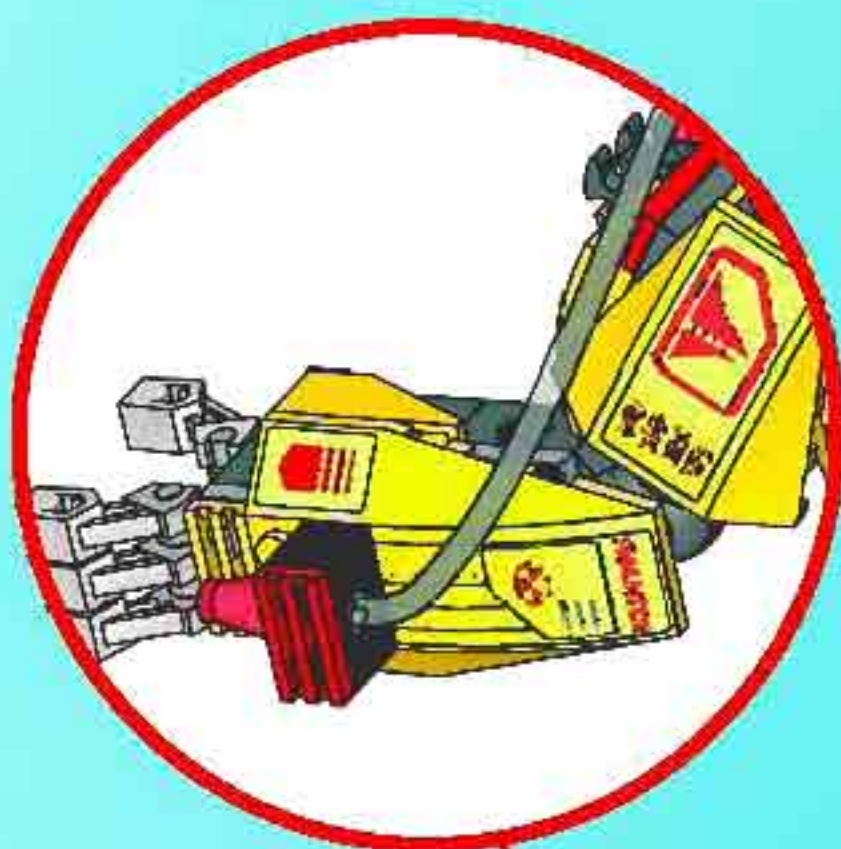

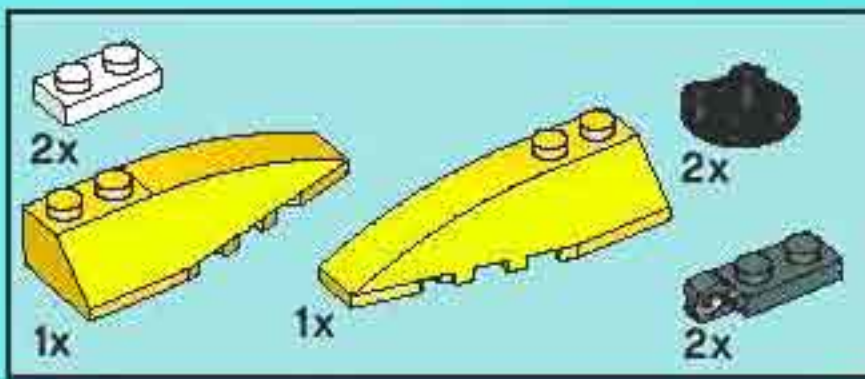

# 22

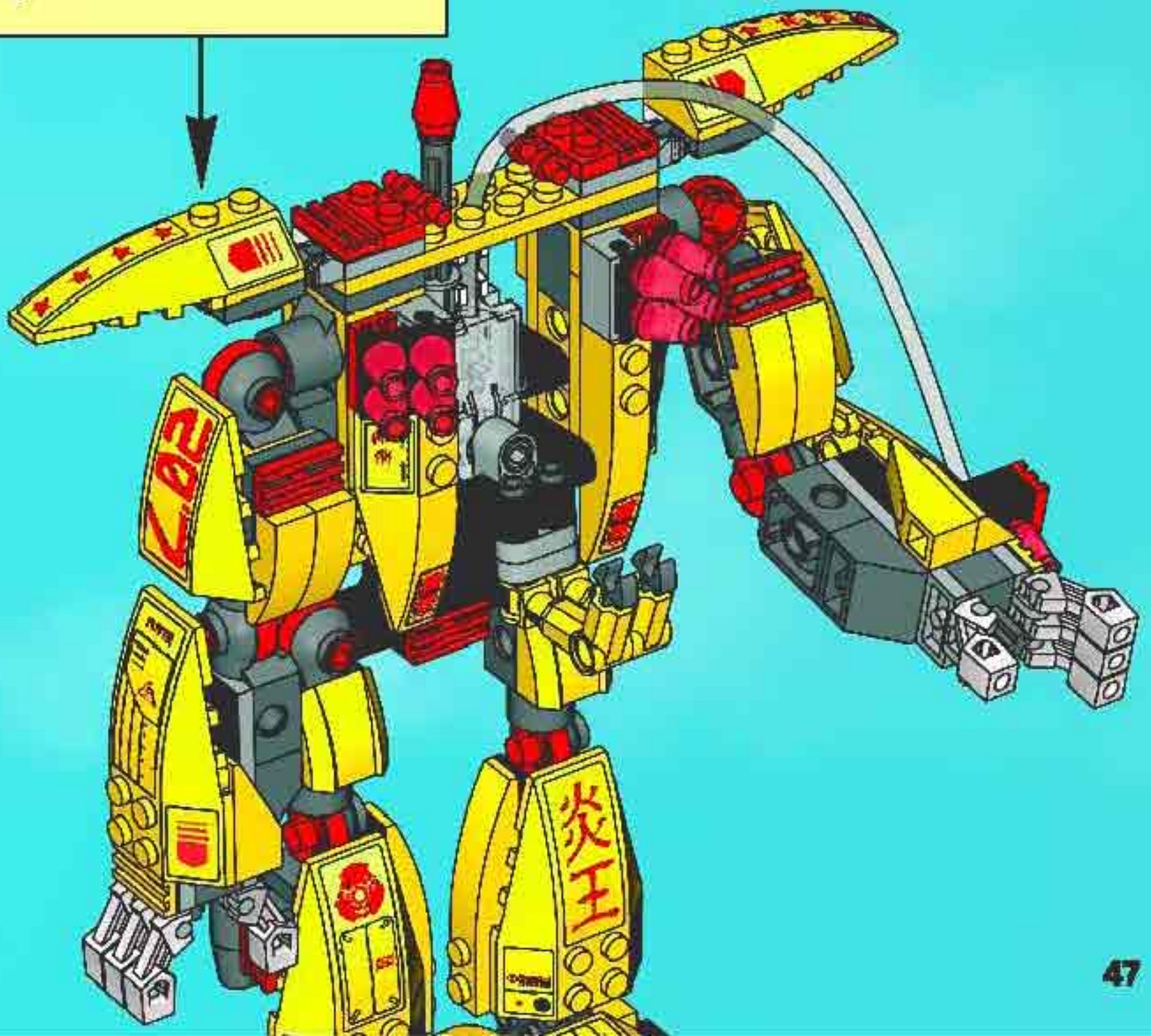
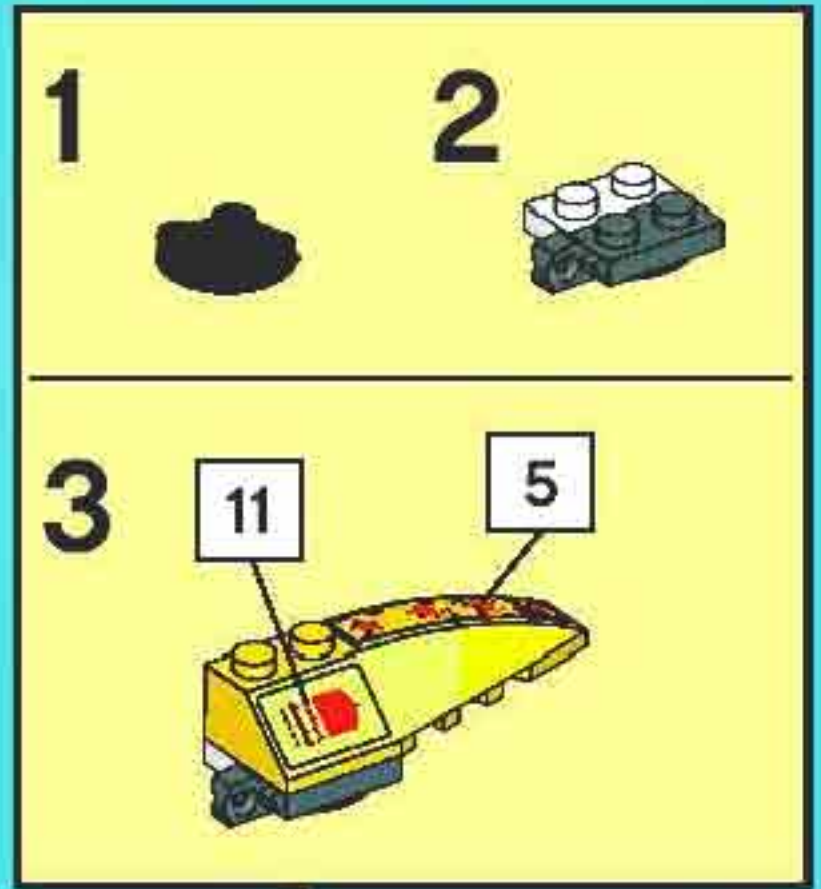
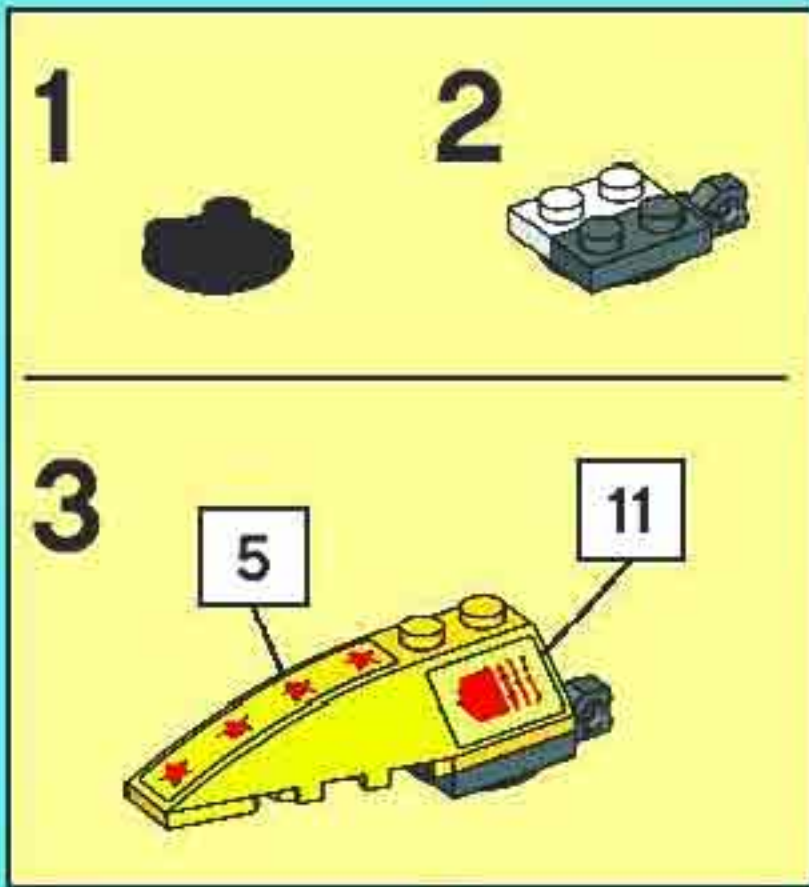

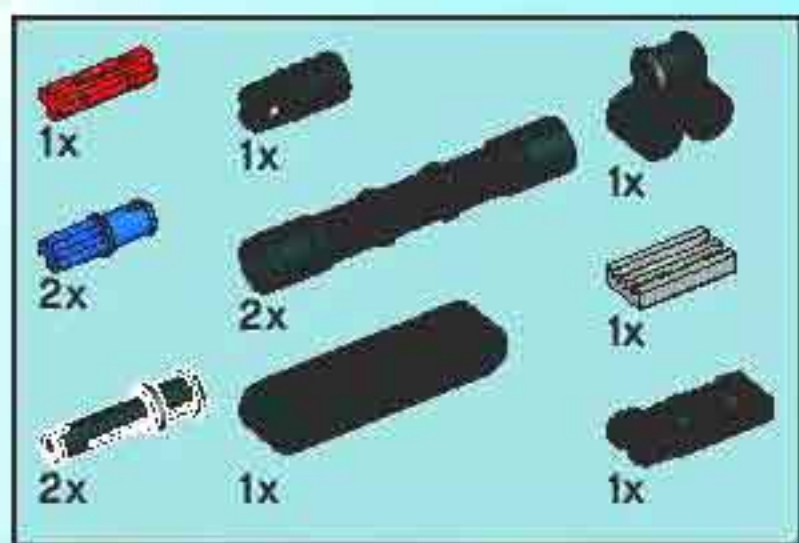

23

1



2



3

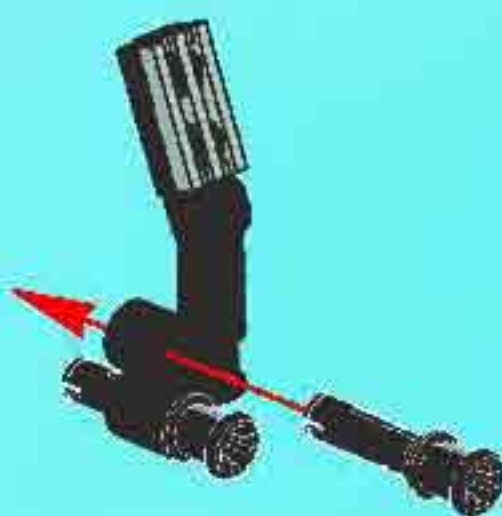

4

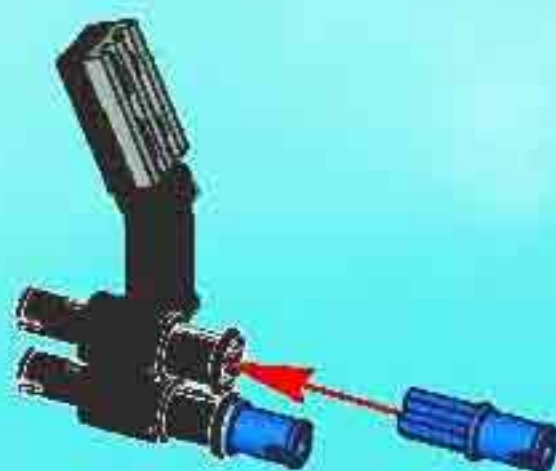

5

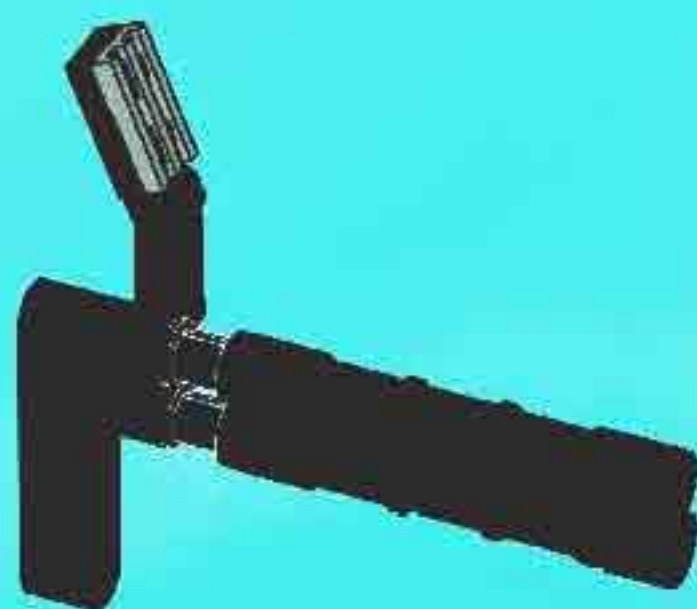

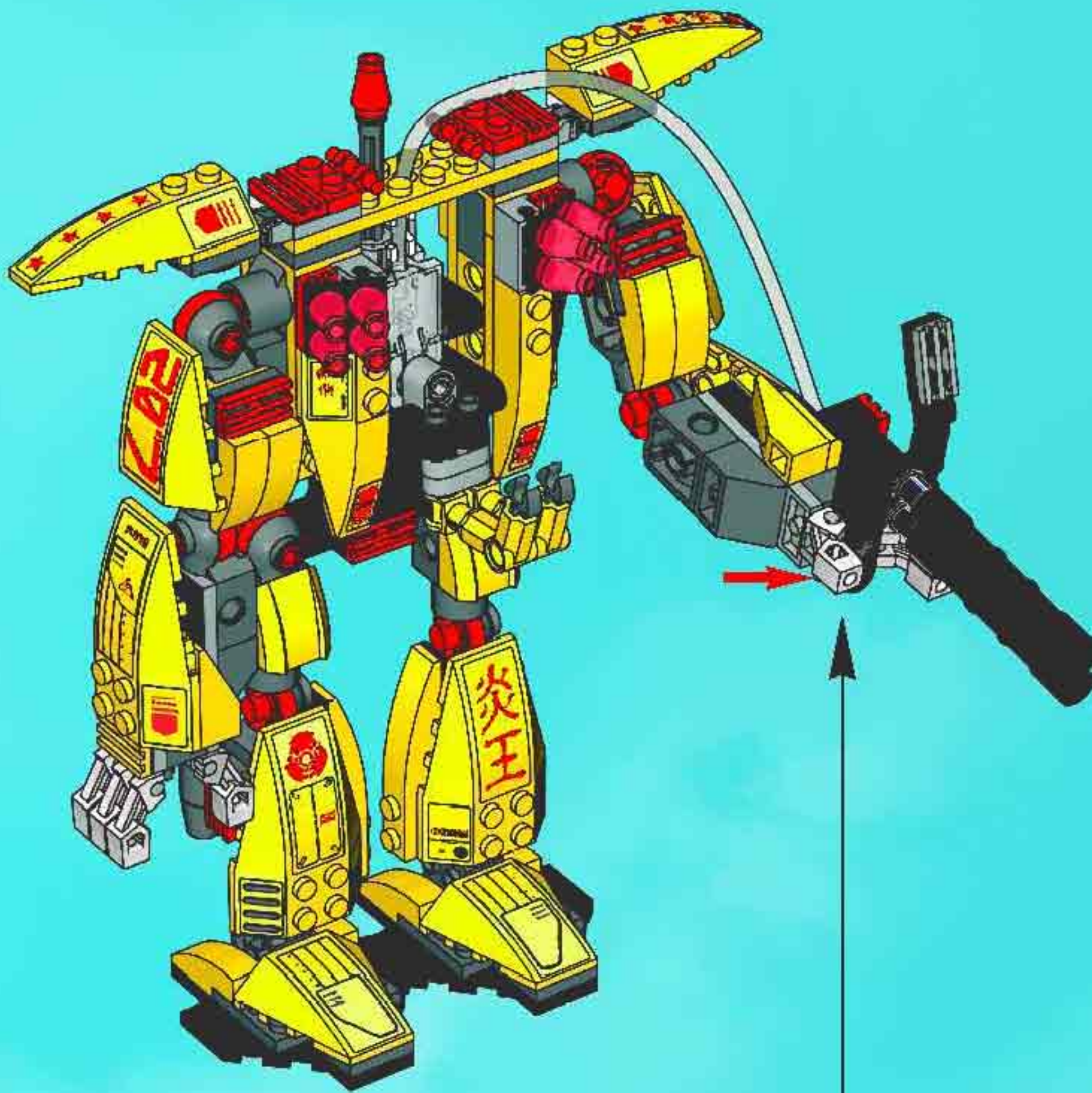

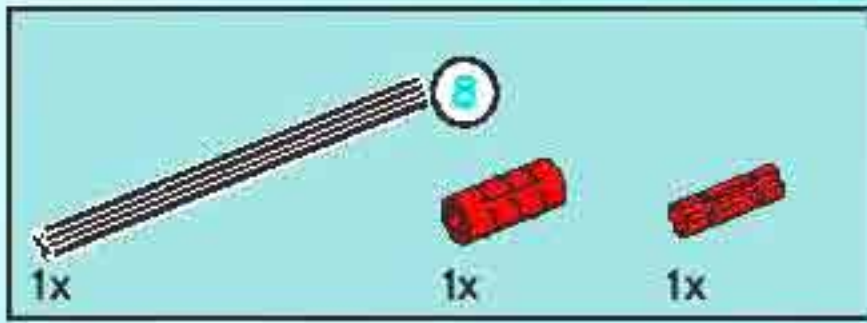

1



2

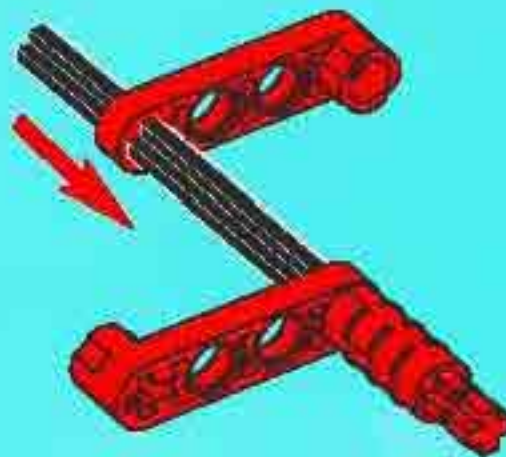

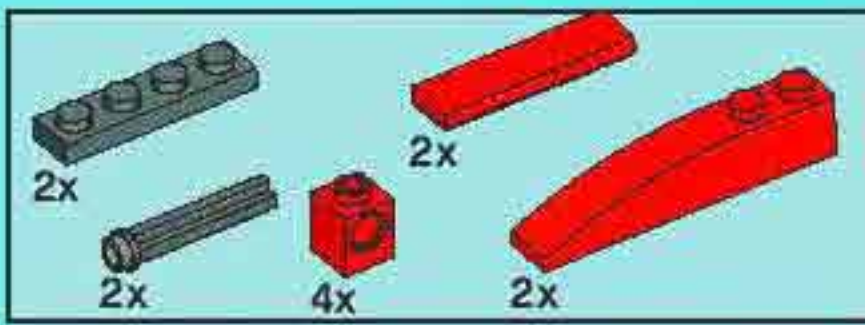

**3**

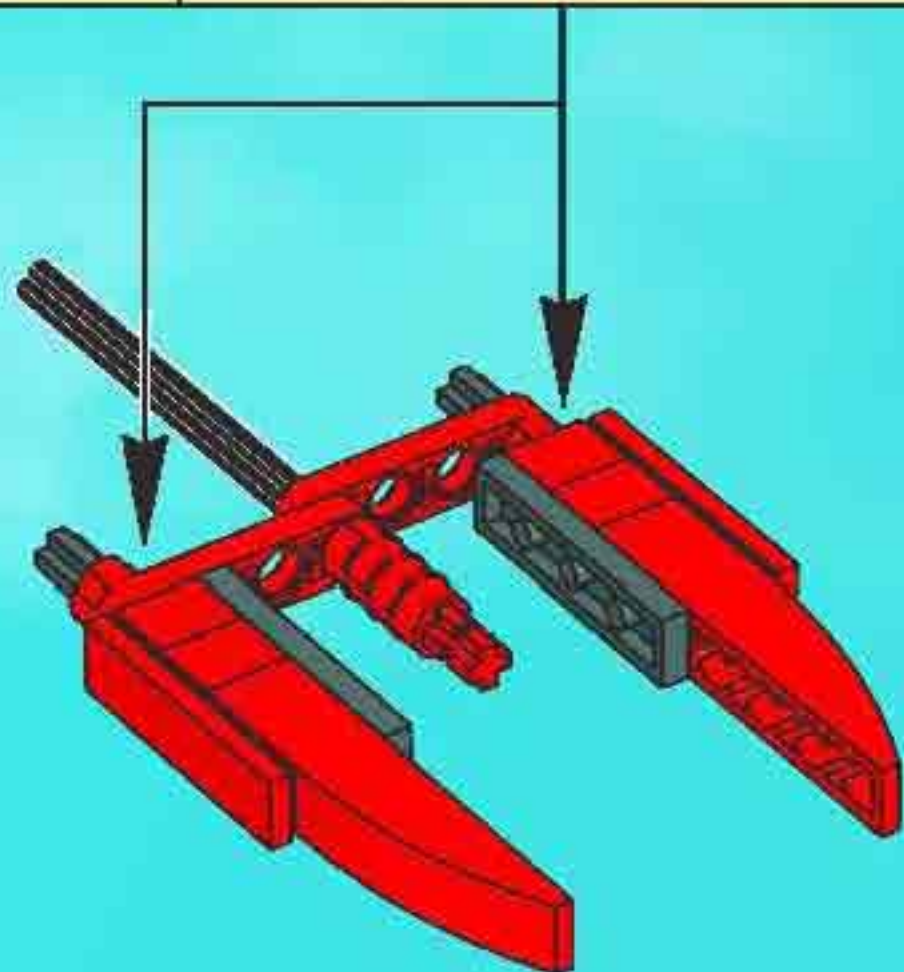
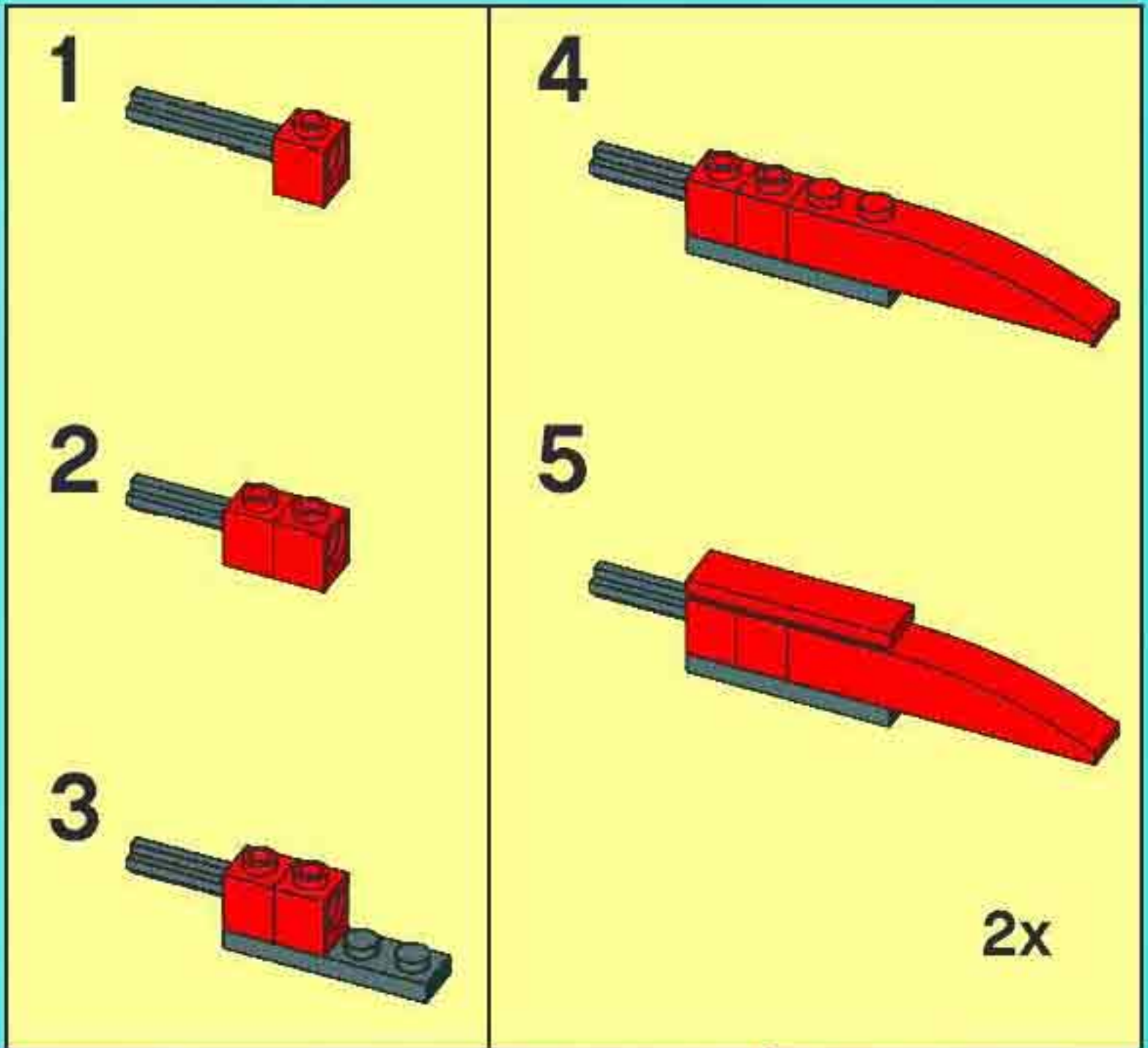



4

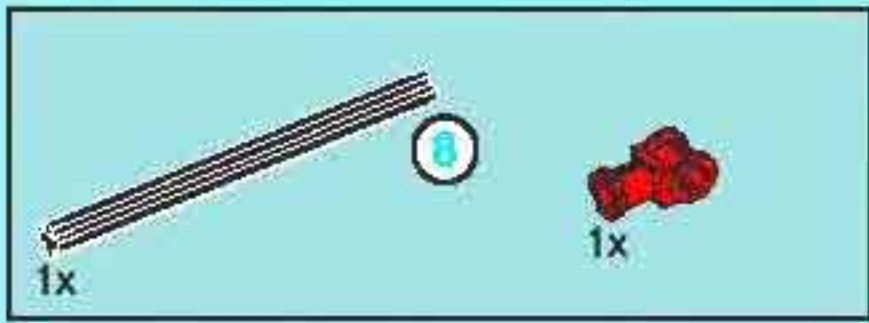
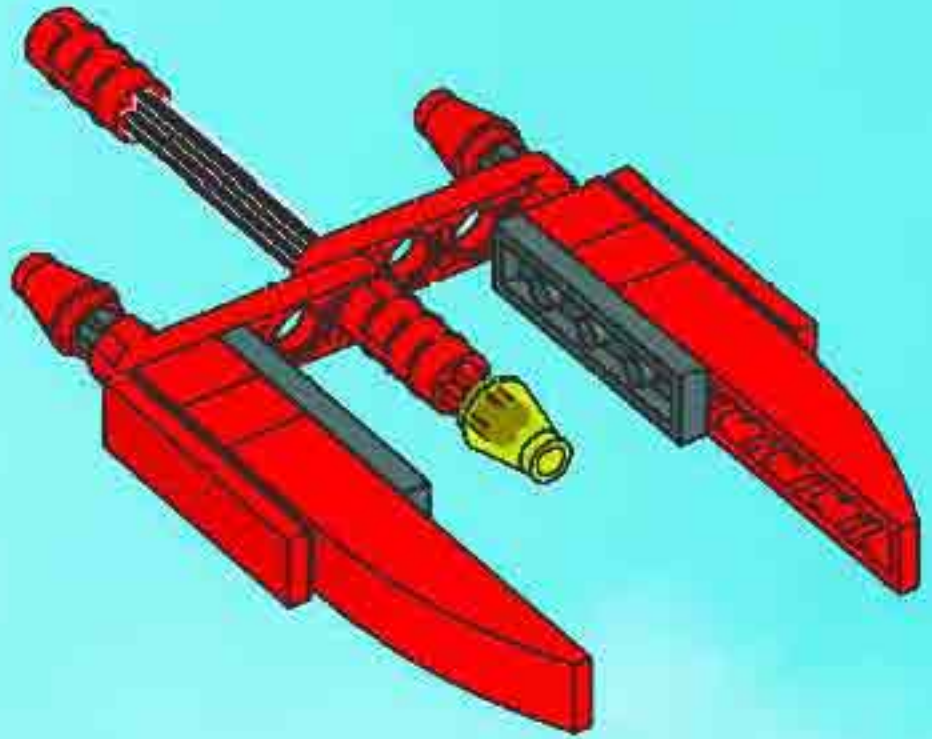

5

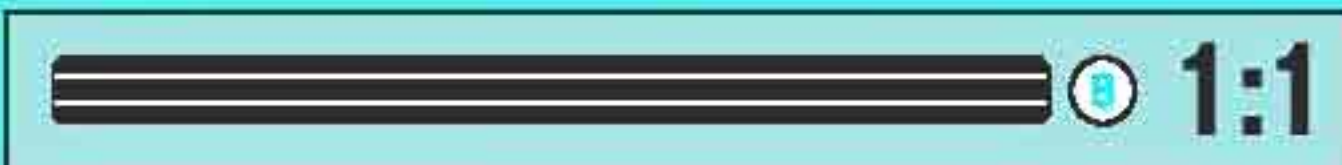
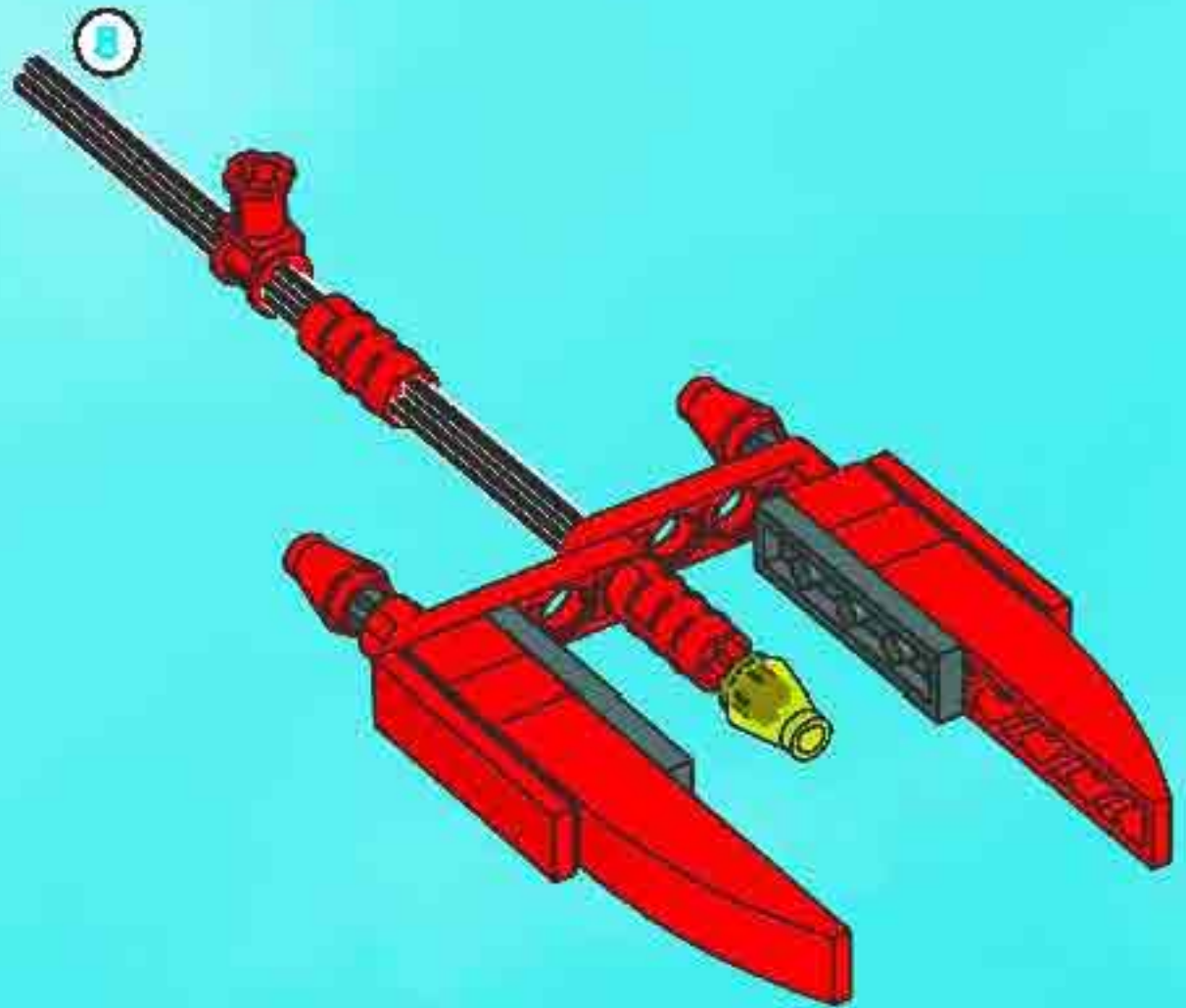

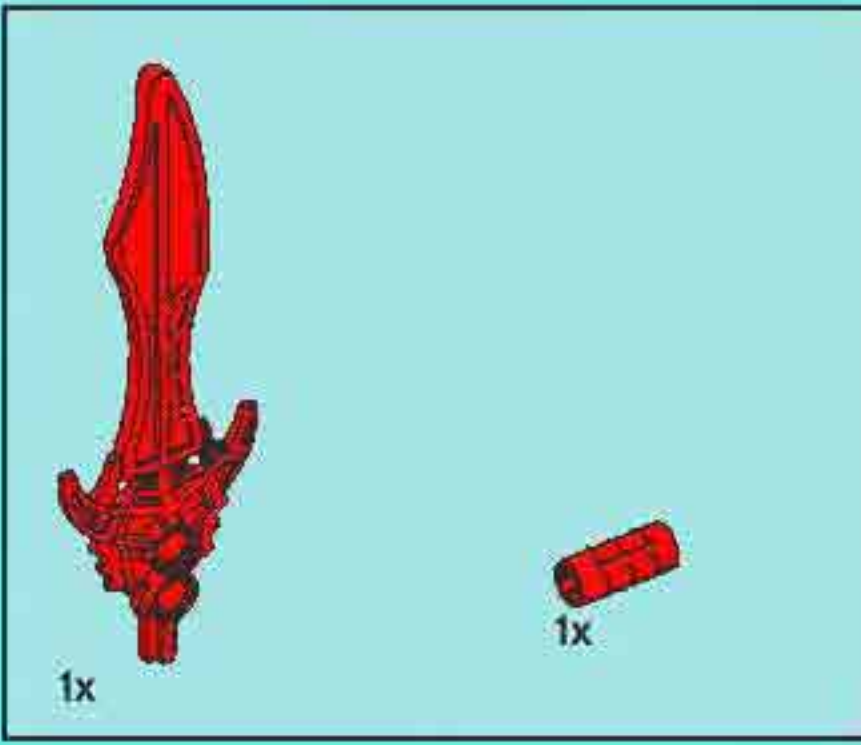

6

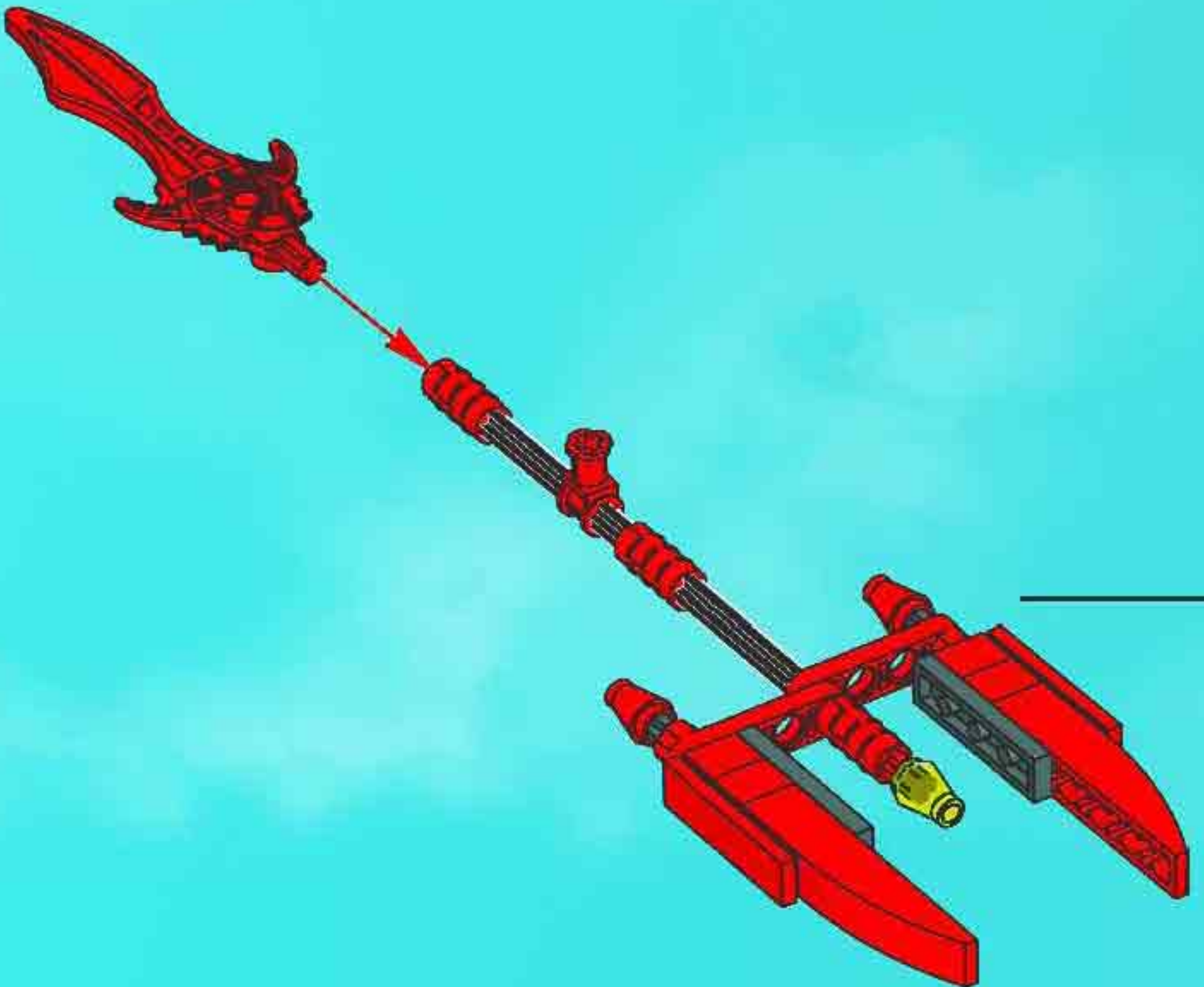

24

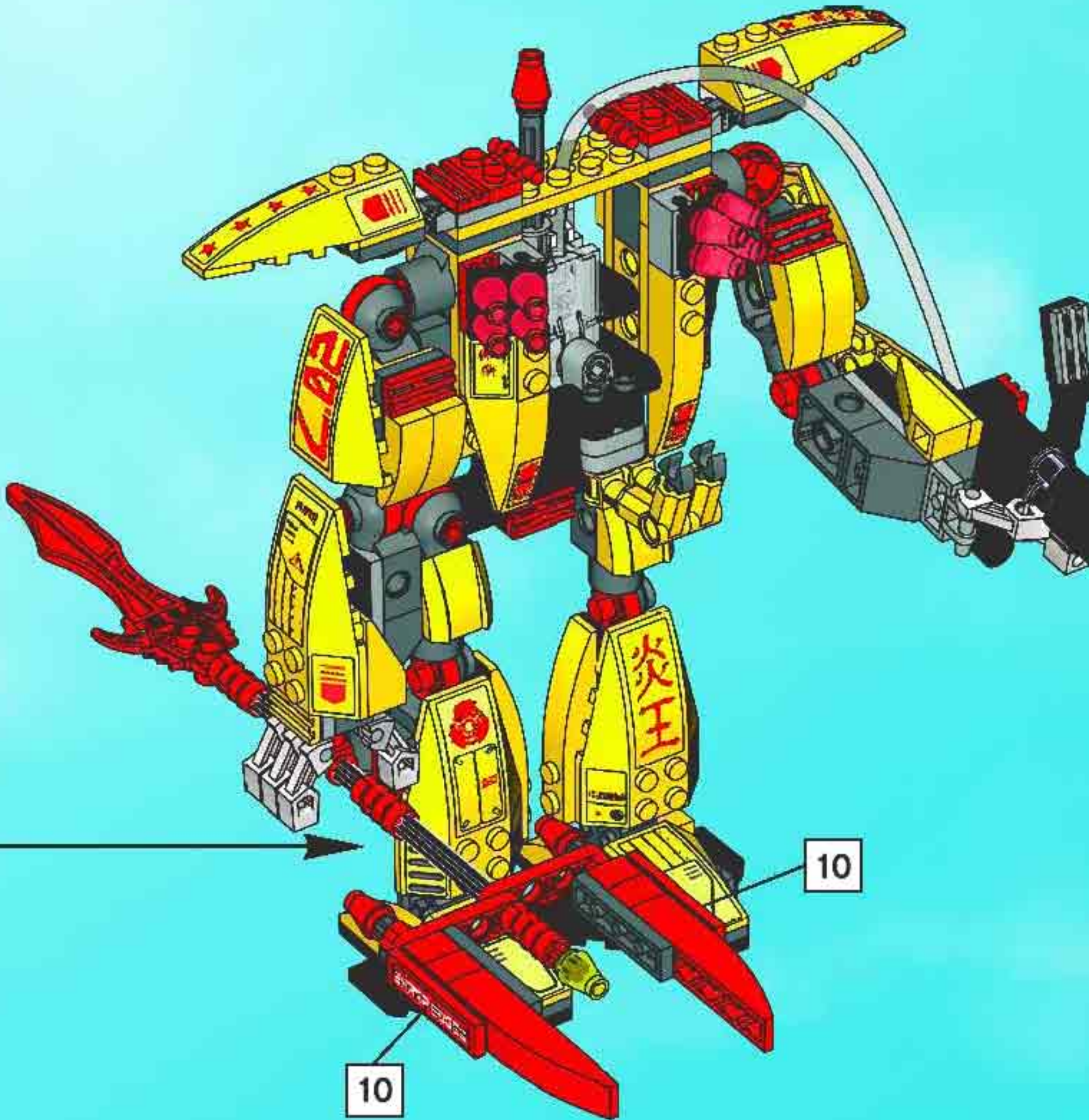

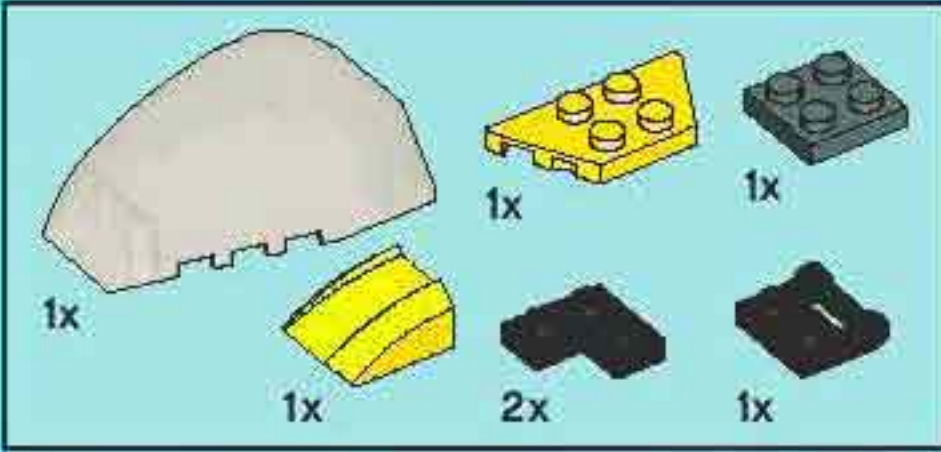
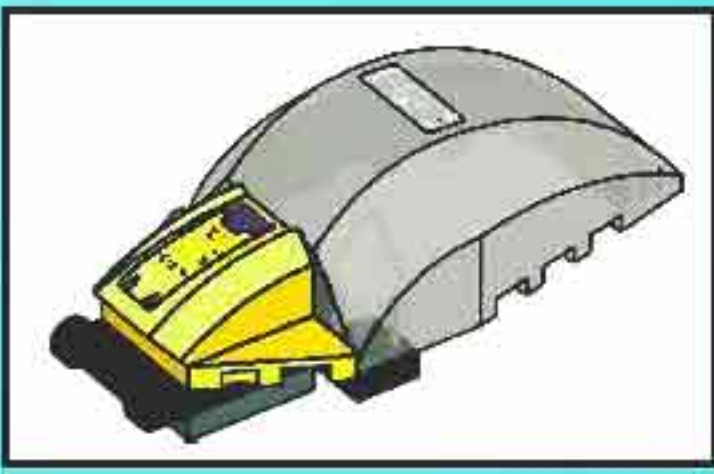

1



2



3



4

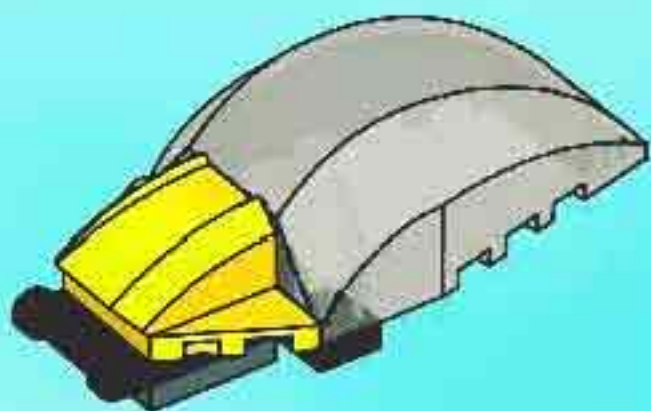

5

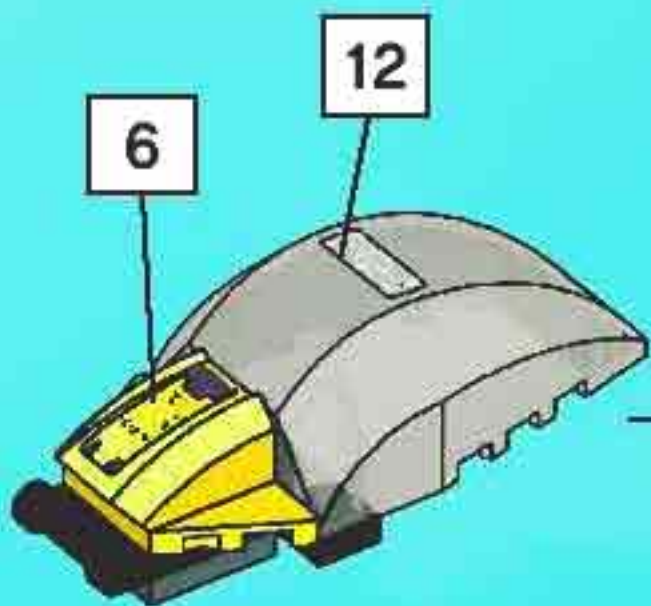

25

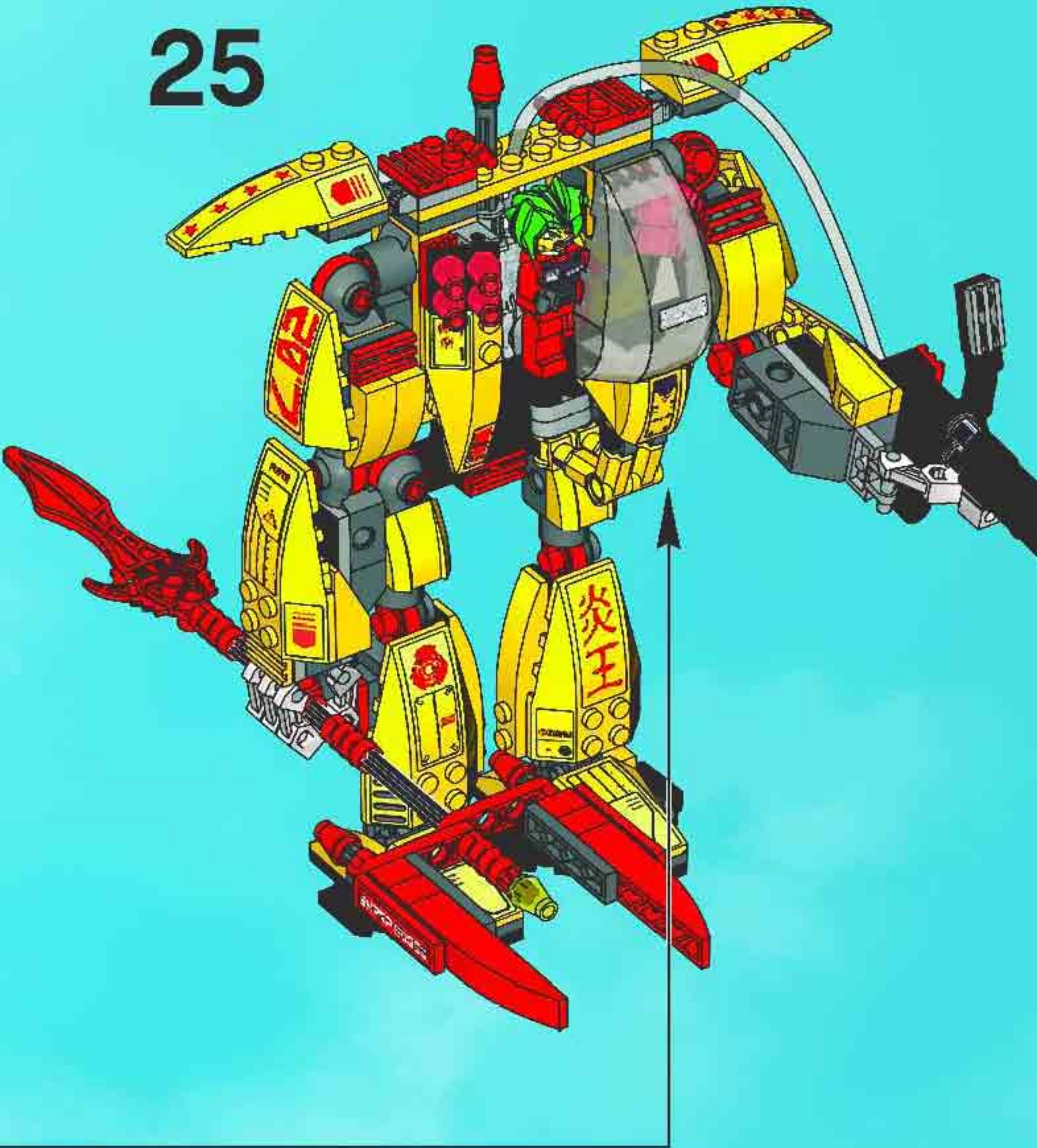

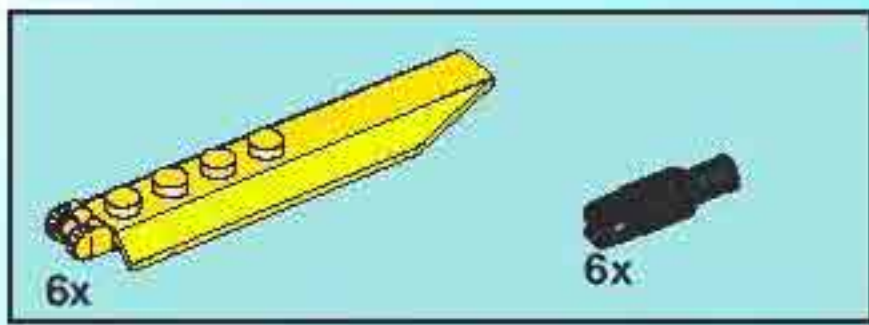

26

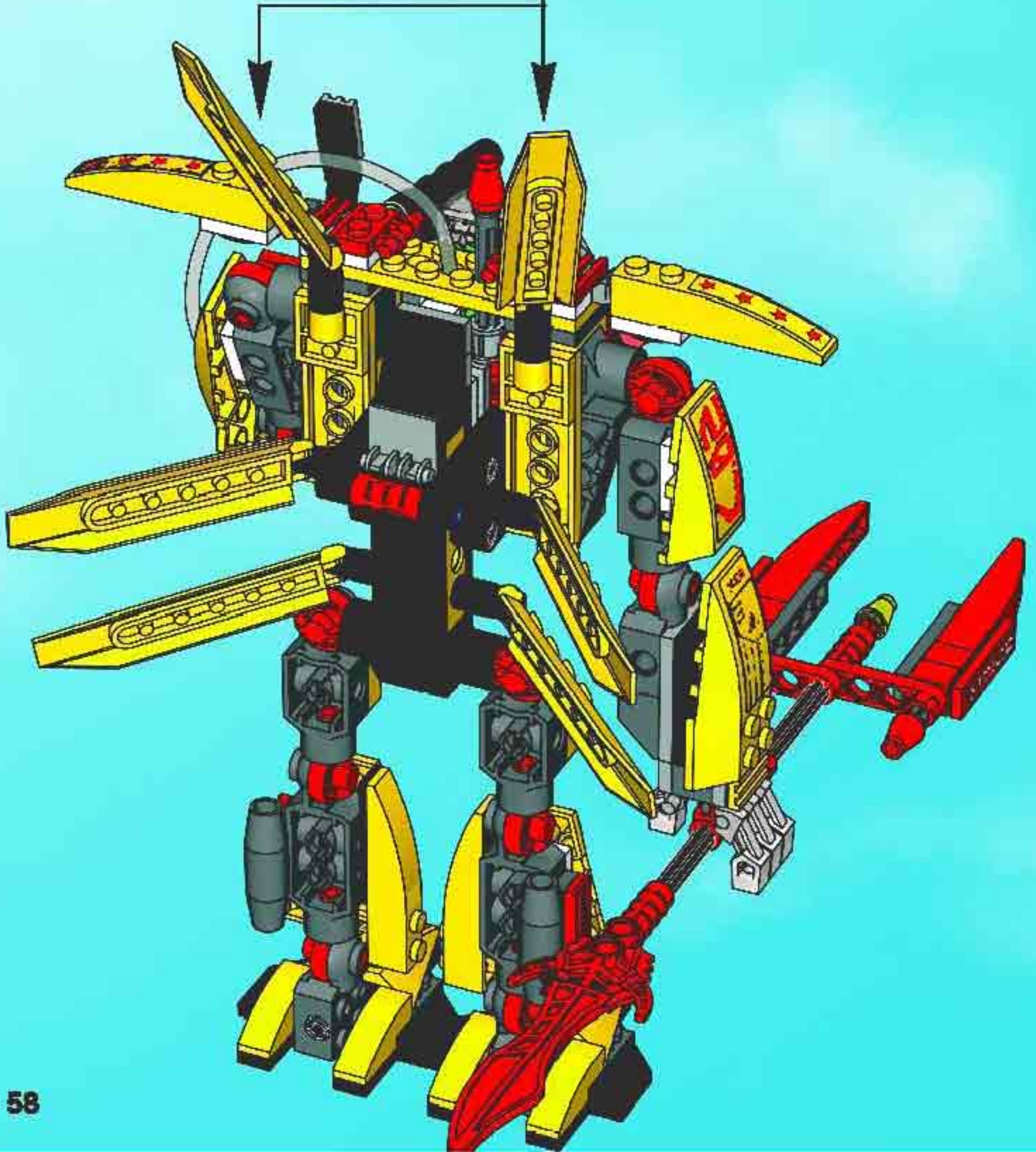
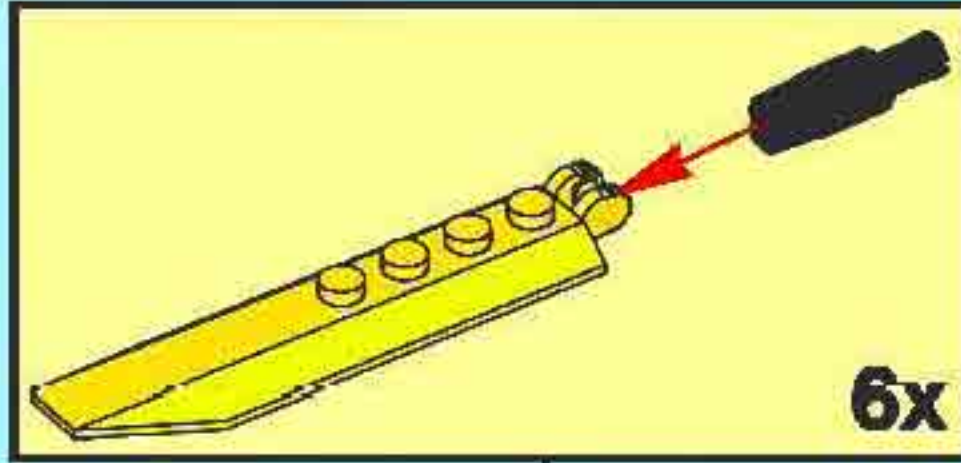

27

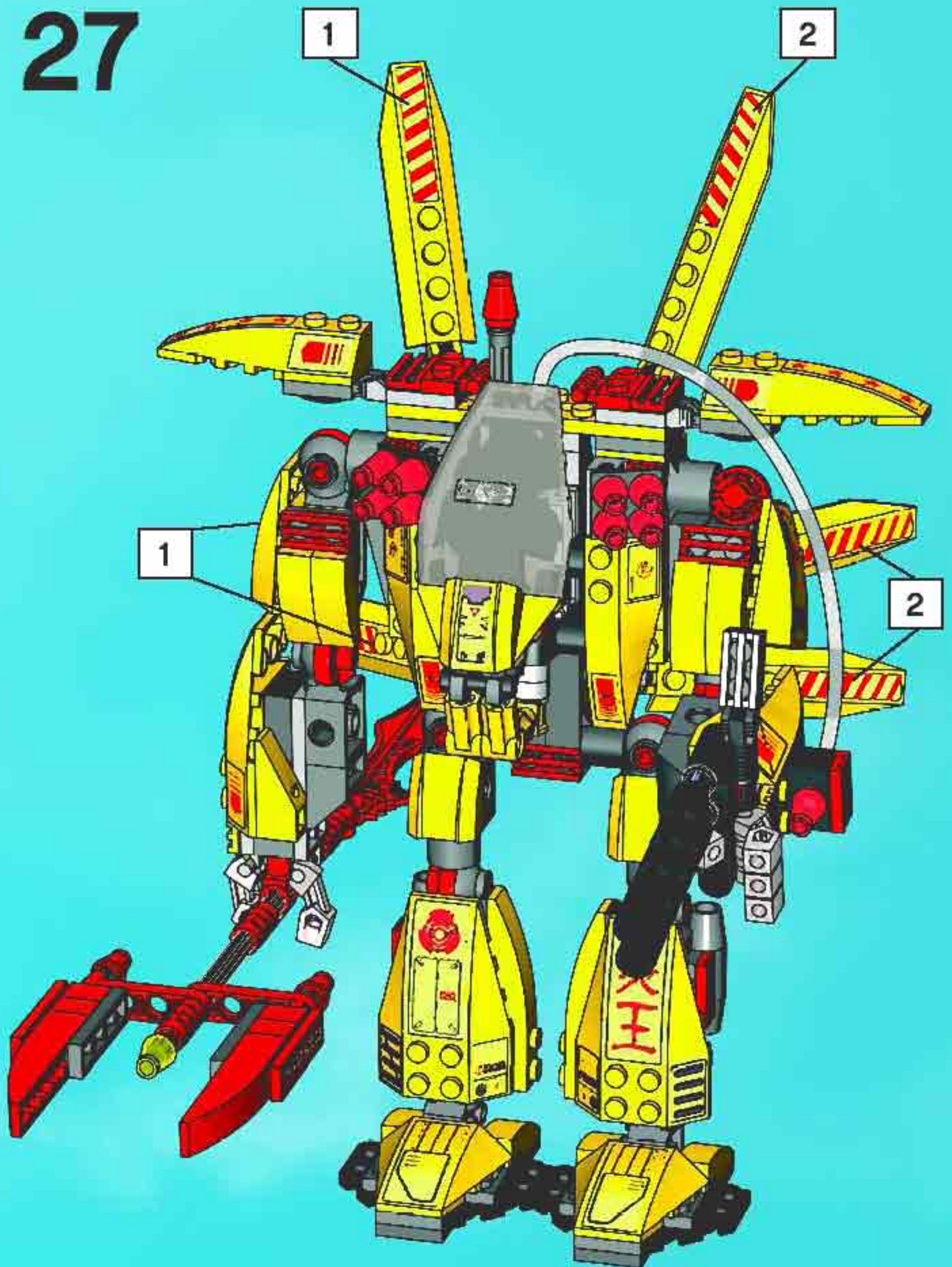



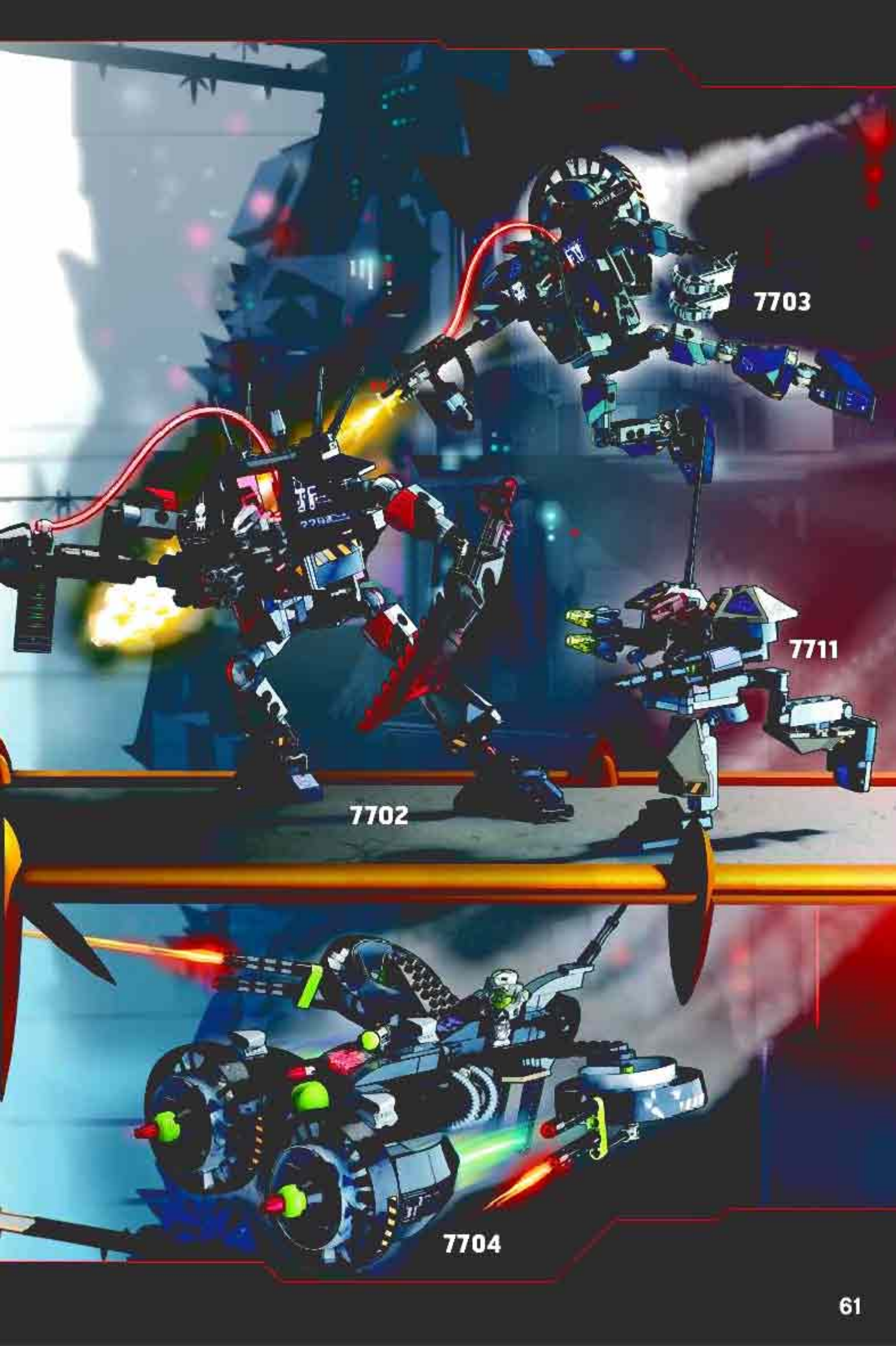

7703

7702

7711

7704

**LEGO**

# EXO-FORCE



[www.EXO-FORCE.com](http://www.EXO-FORCE.com)

# Win!

## Gagne! 当たります

## Gewinne!



### Win LEGO products

We would like to know what you think about your new LEGO product. Log on to the web address below for further instructions.

### Gagne des produits LEGO

Nous aimerions savoir ce que tu penses de ton nouveau produit LEGO. Tu obtiendras davantage d'informations en visitant le site Internet indique ci-dessous.

### Gewinne LEGO produkte

Wir sind sehr an deiner Meinung über dein neues LEGO Produkt interessiert. Gehe einfach zu der unten angegebenen Webadresse – dort findest du weitere Informationen.

### Estimado usuario LEGO

Al contestar algunas preguntas en inglés, francés, alemán o japonés, en el sitio [www.acnielsen.aim.dk/lego](http://www.acnielsen.aim.dk/lego), podrás participar en el sorteo de algunos valiosos premios LEGO.

### Caro Consumidor da LEGO

Ao responder a algumas perguntas em Inglês, Francês, Alemão ou Japonês no endereço [www.acnielsen.aim.dk/lego](http://www.acnielsen.aim.dk/lego) irá participar num concurso para ganhar valiosos prémios da LEGO.

### Kedves Ifjú LEGO Vásárló

Ha ellátogatsz a [www.acnielsen.aim.dk/lego](http://www.acnielsen.aim.dk/lego) honlapra és ott angol, francia, német vagy japán nyelven megválaszolsz néhány kérdést, akkor részt veszel egy versenyben, amelyben értékes LEGO díjakat nyerhetsz.

### 抽選でレゴ製品が当たります

私たちは、皆さんが買い求めのレゴ製品についてどんな感想をお持ちか、知りたいと思っています。質問に答えて、楽しいレゴ製品の抽選に応募ませんか。アンケートの回答には、ほんの3分ほどしかかかりません！詳しくは、以下のウェブアドレスまでアクセスしてください。

[www.acnielsen.aim.dk/LEGO](http://www.acnielsen.aim.dk/LEGO)



Any questions regarding your new LEGO product, please contact:

**Customer Service | Kundenservice**

**Service Consommateurs**

**Servicio Al Consumidor at**

**[www.lego.com/service](http://www.lego.com/service) or dial**



**00800 5346 5555**



**1-800-422-5346**



Discover the **LEGO® UNIVERSE!**

Entdecke das **LEGO® UNIVERSUM!**

Ontdek het **LEGO® UNIVERSUM!**

Découvrez **L'UNIVERS LEGO®!**



**FREE LEGO Magazines**  
Des Magazines LEGO GRATUITS !  
**GRATIS LEGO Magazine**  
KOSTENLOSE LEGO Magazine

**SHOP at HOME**



Sign up now! Jetzt anmelden!

Abonne-toi maintenant! Meld je nu aan!

<http://club.LEGO.com/signup>

[www.LEGOshop.com/catalog](http://www.LEGOshop.com/catalog)