

**Train
SNOT**

**by James Mathis
e-mail: thakius@nmt.edu**



SNOT Synopsis

- A fundamental brick and plate dimensional ratio (5:2)
- Illustrate several SNOT (Studs Not on Top) compatible constructions
 - Illustrations will focus on train rolling stock applications
 - Windows
 - Undercarriage modules
 - SNOT-wise stripes and lettering
 - Wheel shrouds
 - Anatomy of a locomotive– from imagination to reality
 - Examples
 - Basic SNOT
 - More complex interwoven SNOT modules



Credits to the Community

- Notable influence for this presentation comes from Steve Barile, Jason Railton, Jeremy Rear, David VinZant, and Carsten “CaL” Luetjens
 - **and, builders like you!**
- All of whom contribute ideas, tips, and techniques to educate and advance the state of excellence in creative construction solutions.
- Many of my ideas are collaborations, extensions, or copies of others’ ideas.
- Thanks to all of us for:
 - Sharing
 - Collaborating
 - Generating new and exciting creations!



Topics of Techniques

- SNOT
 - Definition
 - Elements & Geometry
 - Philosophy
- Window Treatment
 - Side windows
 - Inverted Cab window
 - Oval door window
- Lettering
- Bumpers and Noses
- Undercarriage
 - Fuel tank
 - Low-height under frame curve
- Stairs on wheels
- Hinges and Vents
- Smooth-curved underbody framework
- 3-high thin-wall panel and the power of 3 studs
 - Uniform 1-plate thick striped box
 - 9-volt wheel shroud
- Anatomy of a Locomotive
 - From Imagination to Reality
 - Sub-model identification
 - Step-by-Step Instructions



SNOT: Defined

- SNOT
 - Studs Not On Top
- Descriptive of any construction method that results in the stud of an element not being facing “up”.
- Results in a vast array of interesting design stylings and functions.
- Opens up a previously unavailable brick resolution
- SNOT 90° and SNOT 180°
 - tube-to-tube, stud-to-stud

Elements of SNOT

- This presentation uses the following elements to achieve SNOT rotations:
 - 1x1 Technic brick with side hole
 - 1x4 Technic plate with pass-thru holes
 - “headlamp” brick: 1x1 brick with side stud and side hole
 - 1x2 – 2x4 “L” bracket
- There are many more SNOT techniques
 - Too many to include all of them in this presentation
 - Explore and discover your own

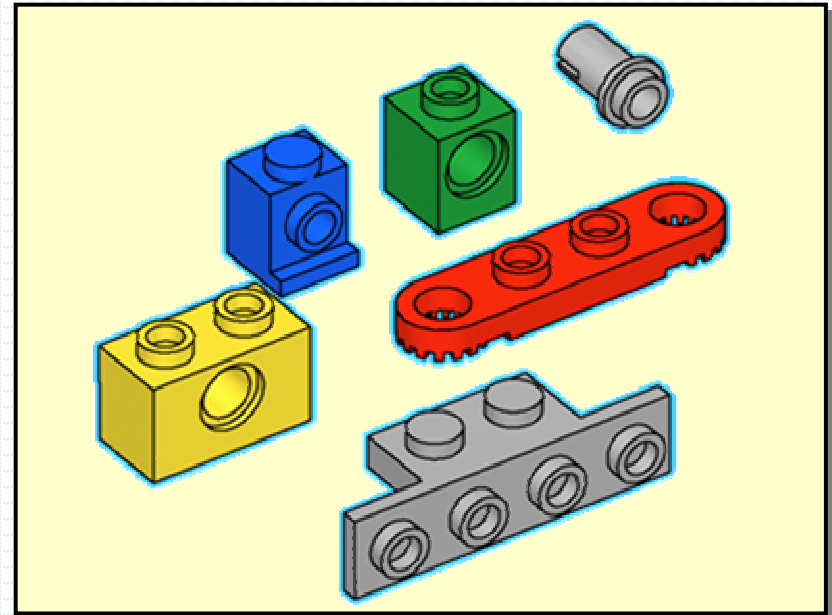

Fundamental SNOT Geometry

- **5 : 2** mantra

- 2 stud SNOT height = 1-2/3 brick height*

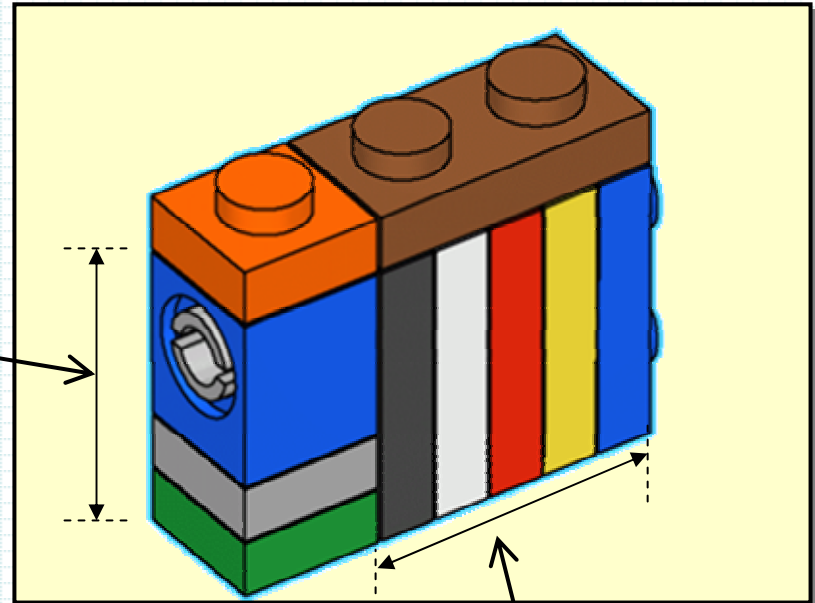

- 5 plate SNOT thickness = 2 studs width*
- Useful for integrating SNOT modules into main superstructure of a studs-up model

*These two descriptions are equivalent– the same thing! One is simply the SNOT of the other.

Fundamental SNOT Geometry

The 1/2-plate thickness

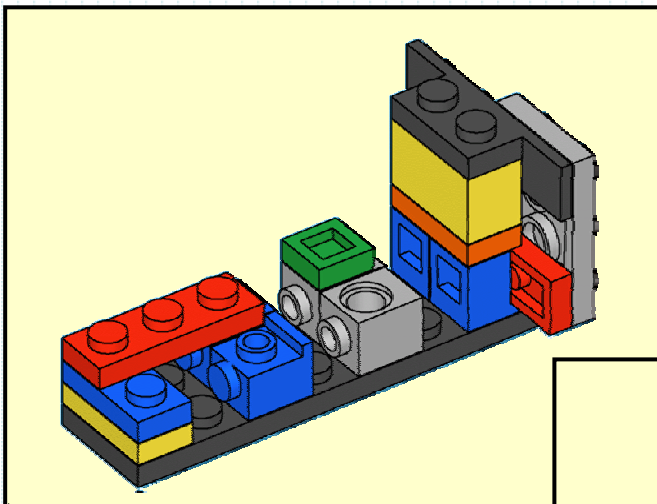

This juxtaposition of elements would result in a slight “rocking back” of the blue headlamp brick due to the adjacent stud height being slightly greater than 1/2-plate .

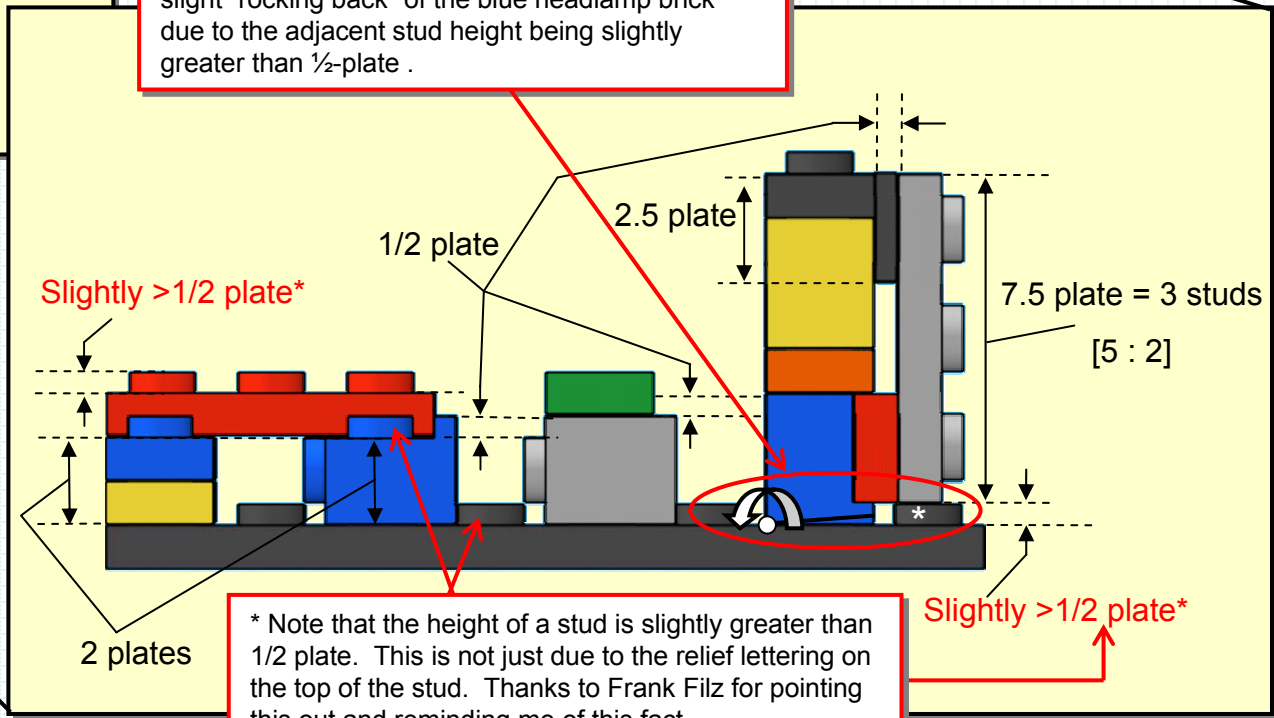

* Note that the height of a stud is slightly greater than 1/2 plate. This is not just due to the relief lettering on the top of the stud. Thanks to Frank Filz for pointing this out and reminding me of this fact.

SNOT Construction Philosophy



- Visualize your overall model
- Identify sub-sections of the model that define endpoints or unique partitions within the main overall model structure
- Can these sub-sections benefit from a SNOT-wise approach?
 - Yes: then manage the SNOT-wise construction based on the basic SNOT-compatible geometry
 - Build the main model body to accommodate the insertion of the SNOT sub-model

Low Aspect Ratio Train Window

- 10 SNOT plate thickness = 4 Studs width (5 : 2)
- String this window style together for train windows
- Note the 2x2 “L” and 1x2 “jumper” to hold everything in place.

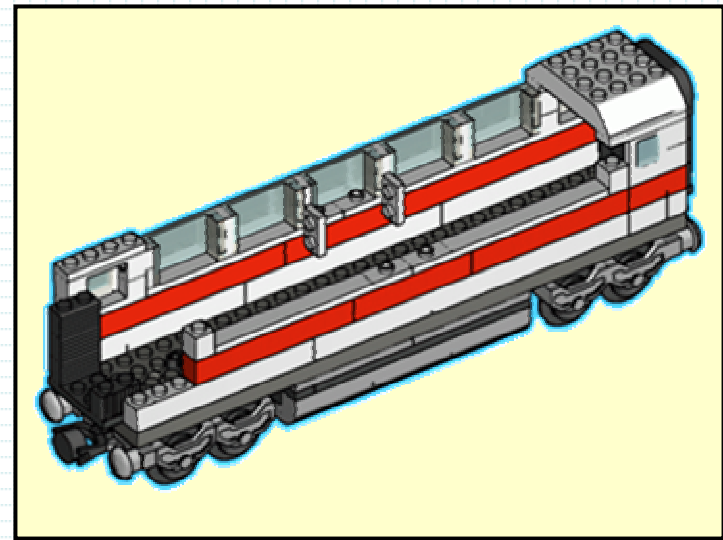
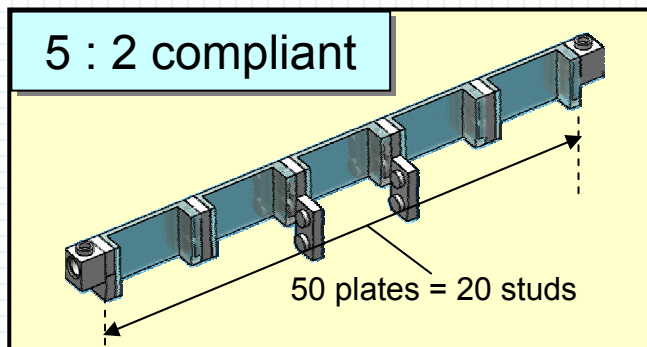
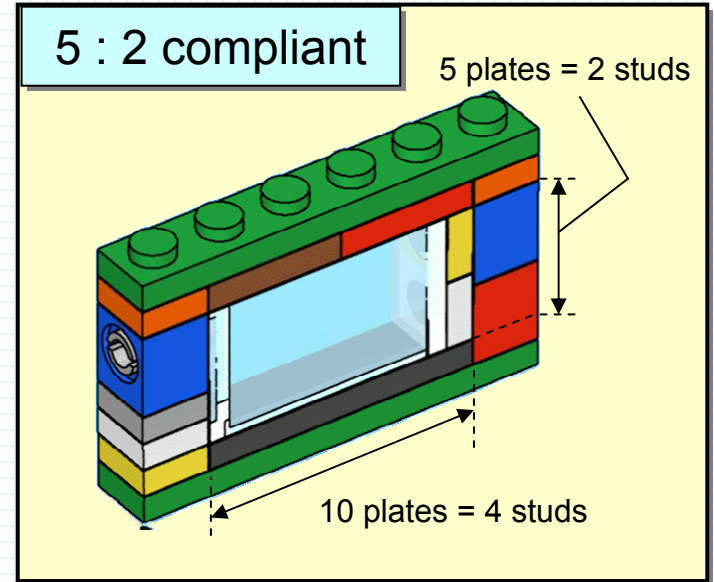

More SNOT Window Arrangements



5 : 2 compliant

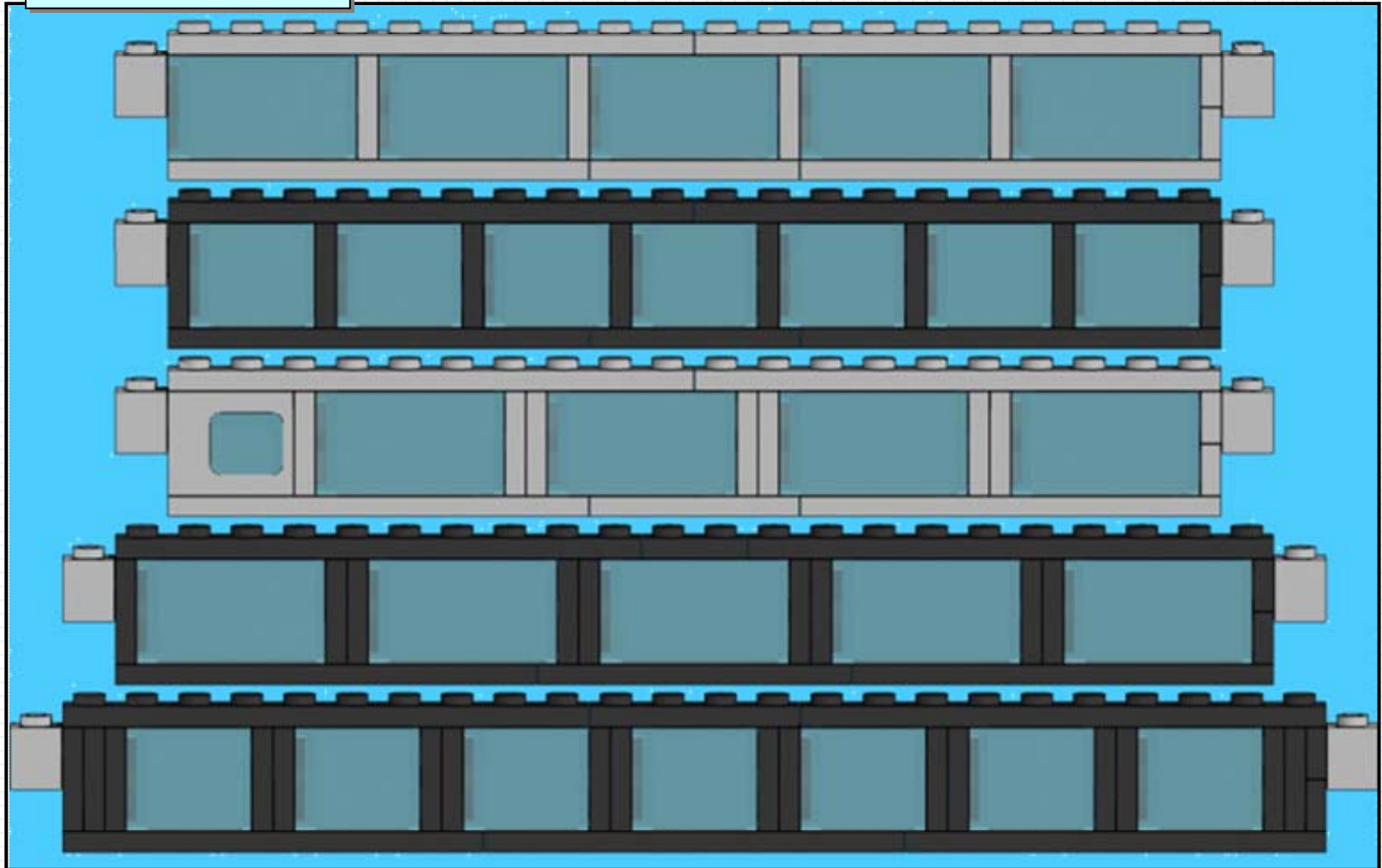

Inverting a Window

- SNOT-Wise Locomotive Cab Window
- When the complementary inverted element doesn't exist— SNOT it!

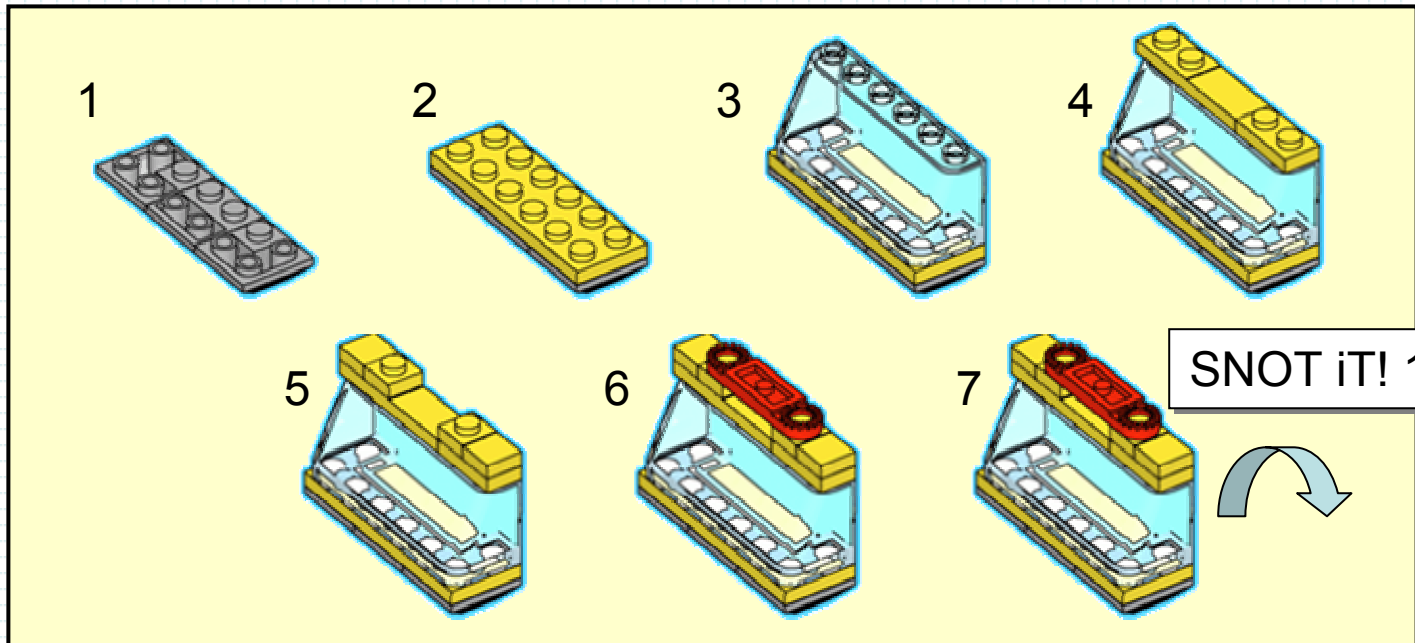

Ovals from Arches (1 of 3)

Shaping a train door

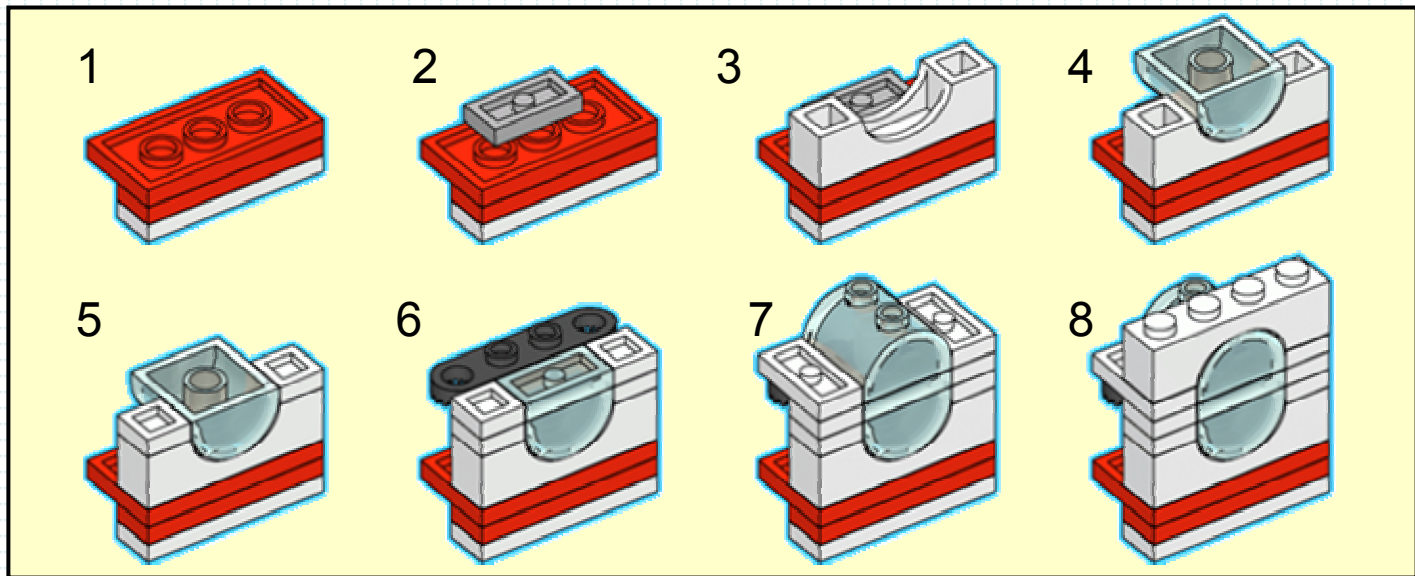

Oval Window by Steve Barile (2 of 3)

- Note use of 2 stud long Technic axles in tube-to-tube orientation
- Window is lower profile than previous window by 1 plate

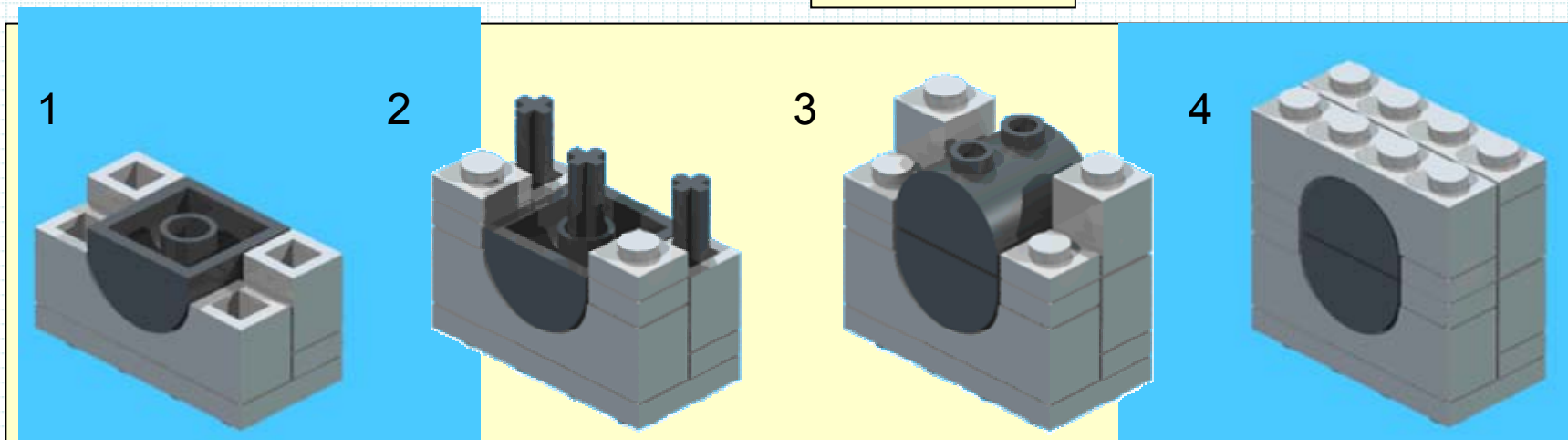
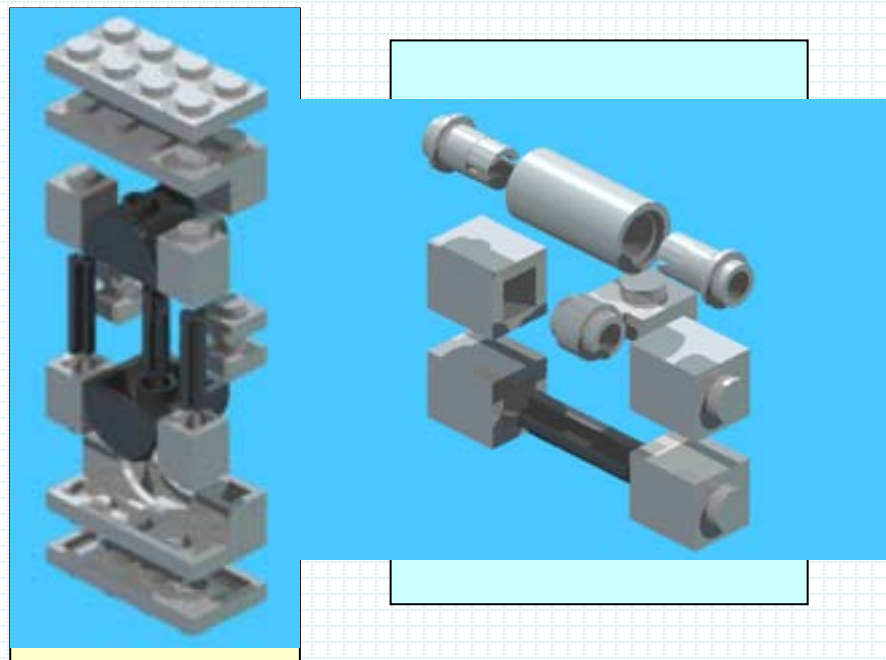

Ovals from Arches (3 of 3)

- Another Train Door Window Style
 - A tight squeeze!
 - The space between the red arches in which the black tiles are recessed may not be quite 3 studs wide– but it is very close!

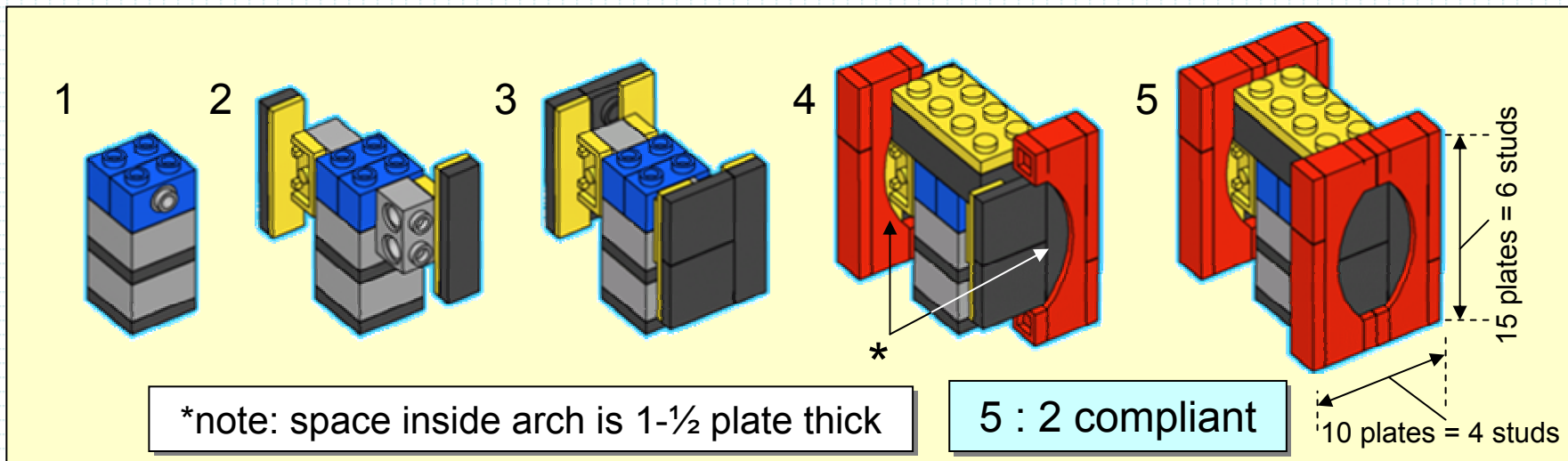
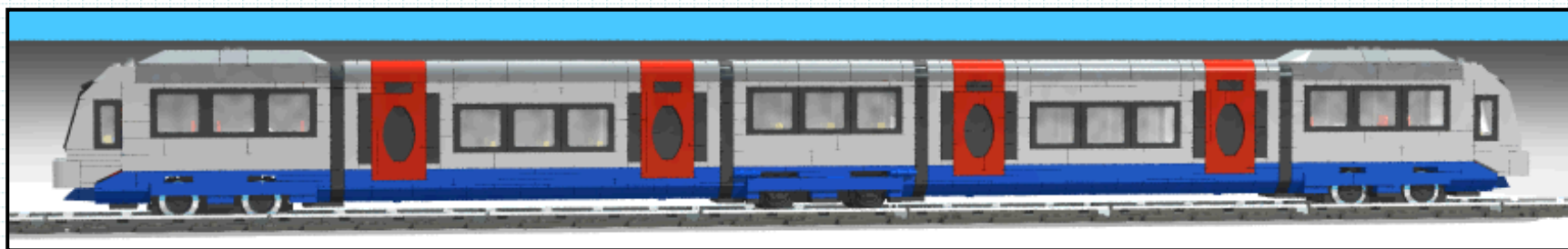

Lettering

- Lettering in the 5:2 format
- An extension of the SNOT side windows
- Mix SNOT with Studs-Up to create design patterns
- Step-by-step instructions available in back-up slides

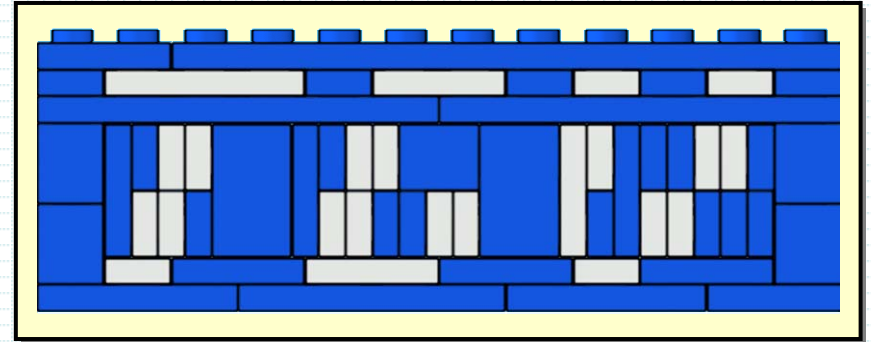

1/2-Plate SNOT: Curved Nose Bumper

15 SNOT plate thickness = 6 studs (5 = 2)

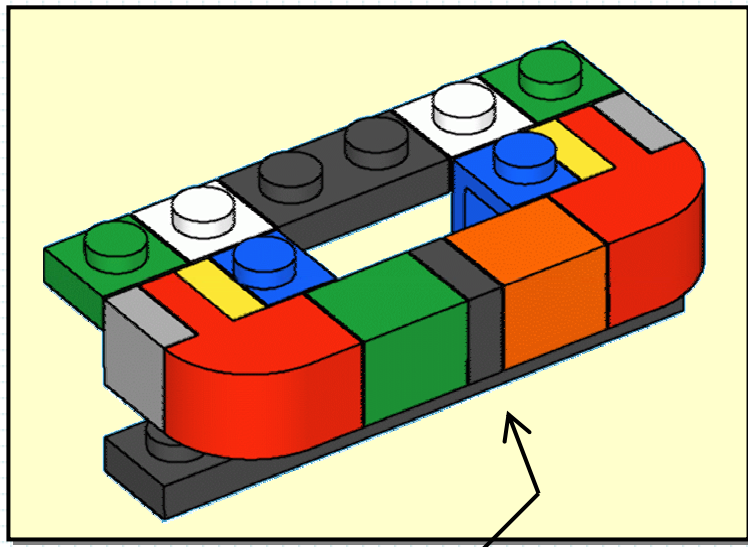
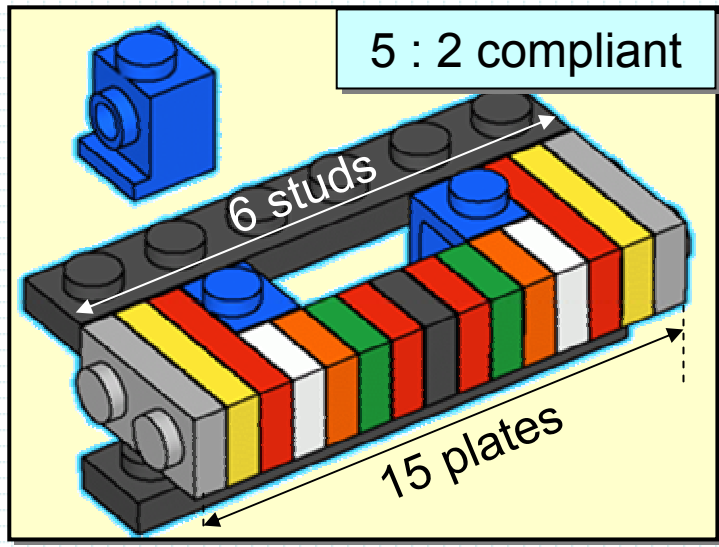

Centered SNOT plate!

A Seamless Cylinder

fuel tank

5 : 2 compliant

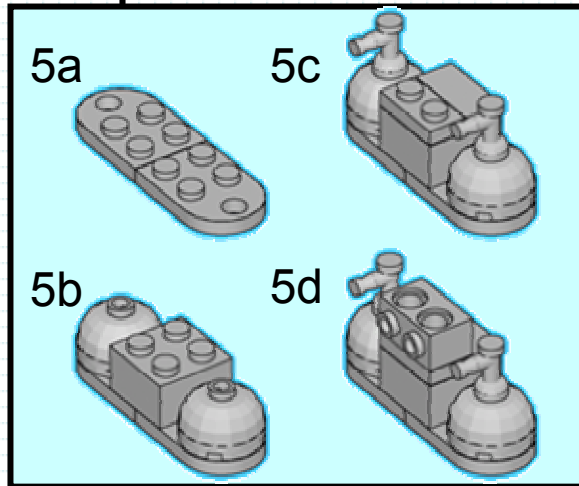
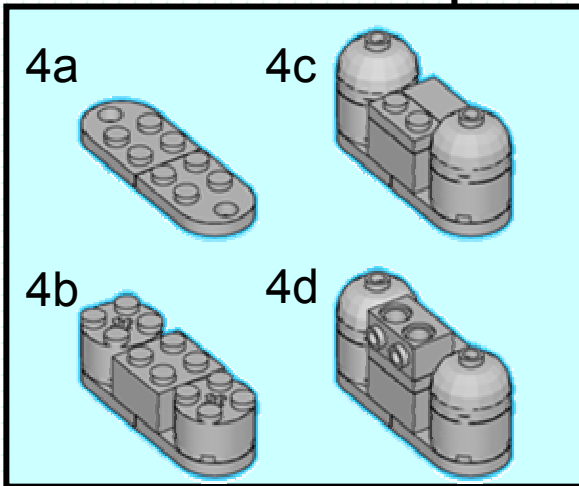
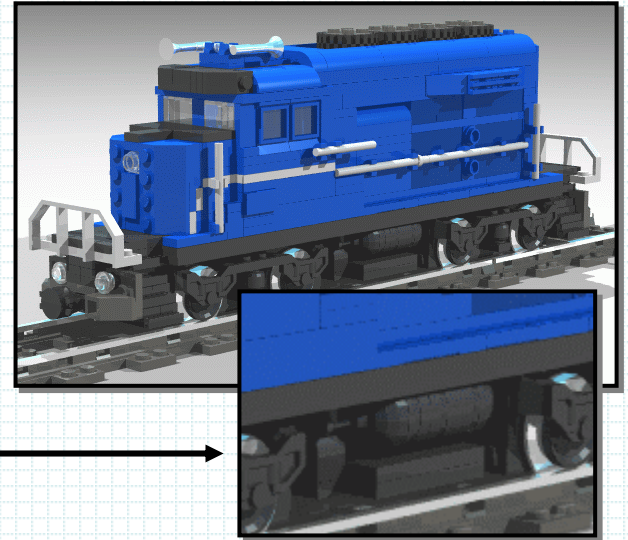
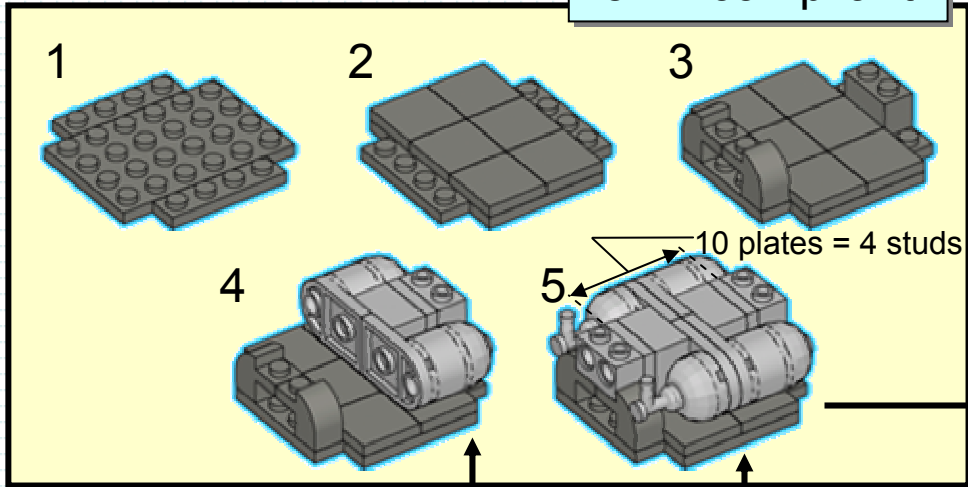

Low-Profile Curved Under-Frame

1/2-plate SNOT works, too

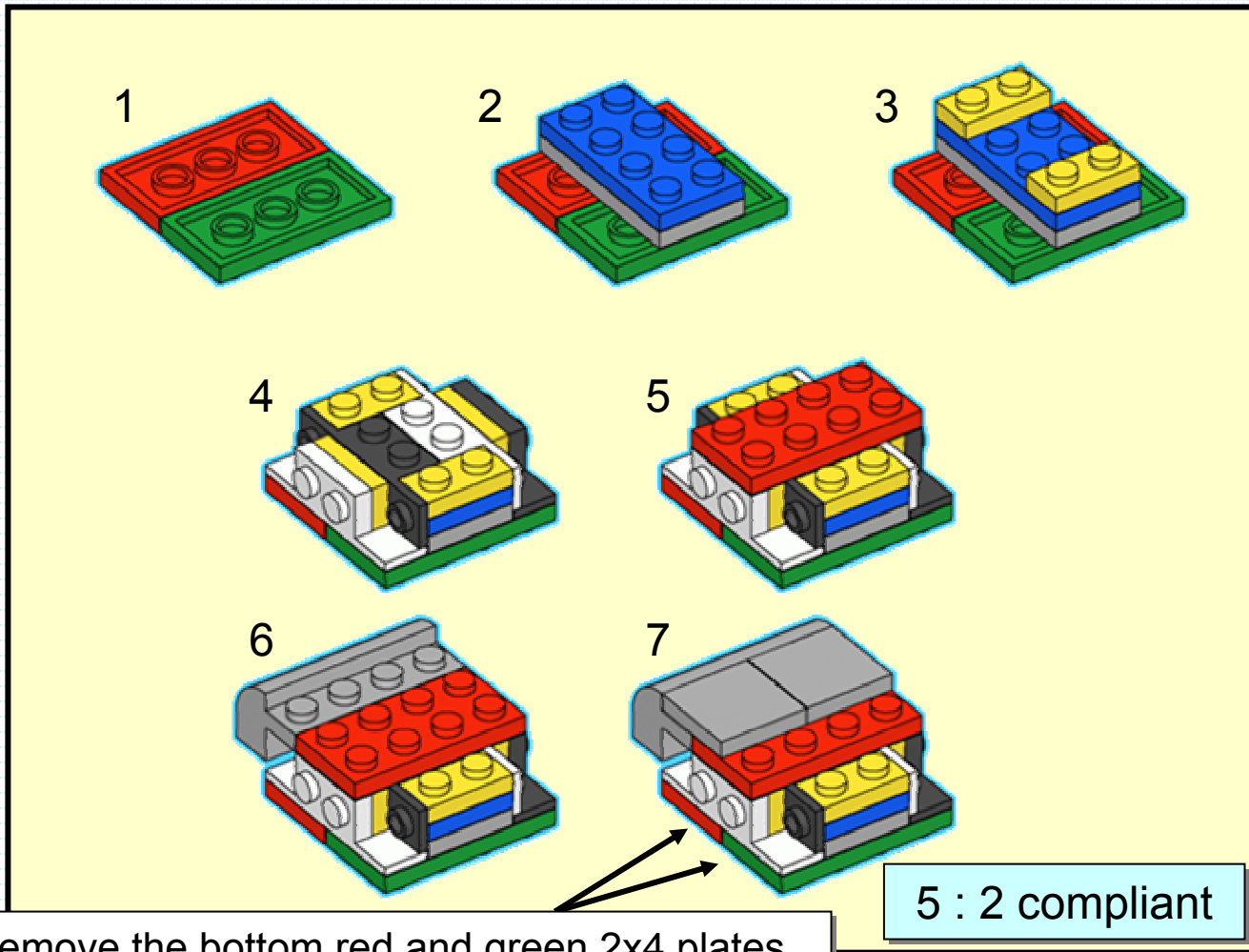

Remove the bottom red and green 2x4 plates to reduce the profile further

Truck-Mounted Steps

Mount stairs to wheels

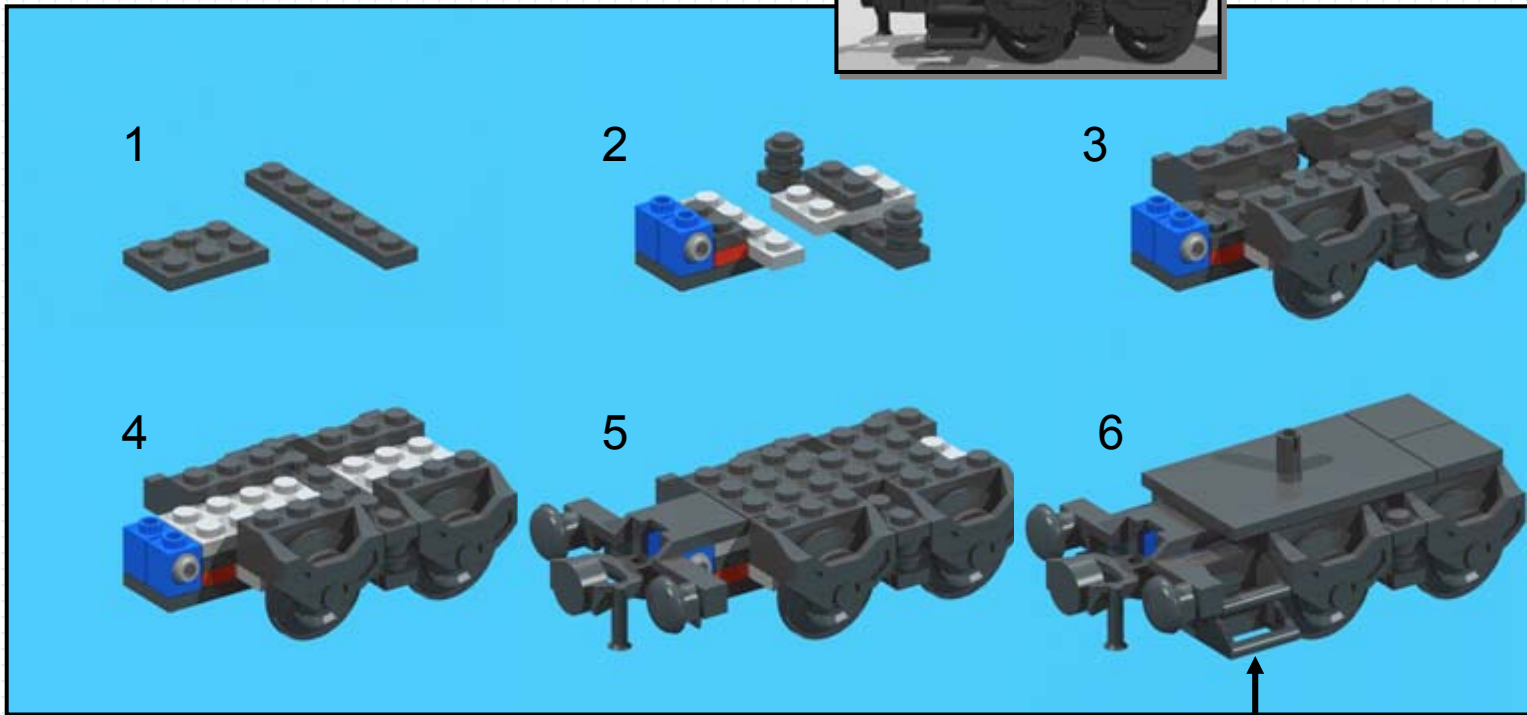

Hinged Framing & Striping

- Hinges and tiles contour sloping nose
- Provides “facing” and thin angled striping

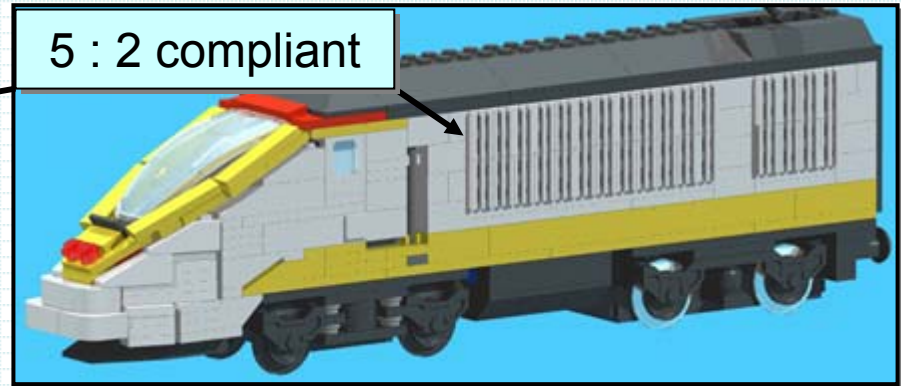

1/4-Round Coach Underside by CaL

- Carsten “CaL” Luetjens
 - Brought this construction technique to public attention
 - 8 studs wide

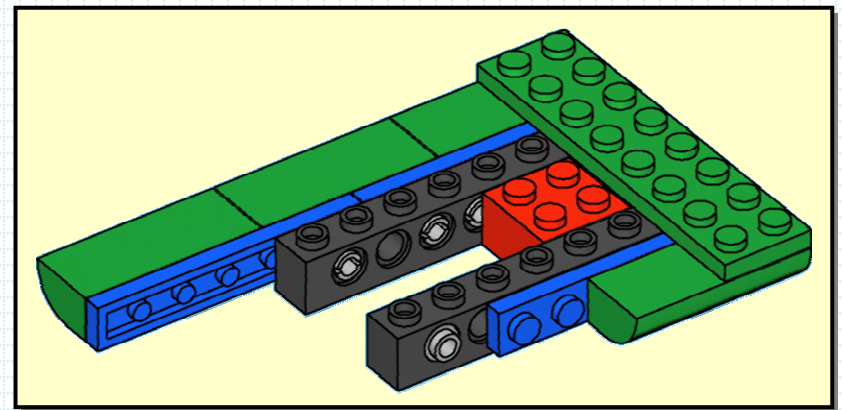

1/4-Round Coach Underside

Smooth the edge of the underside of a train car

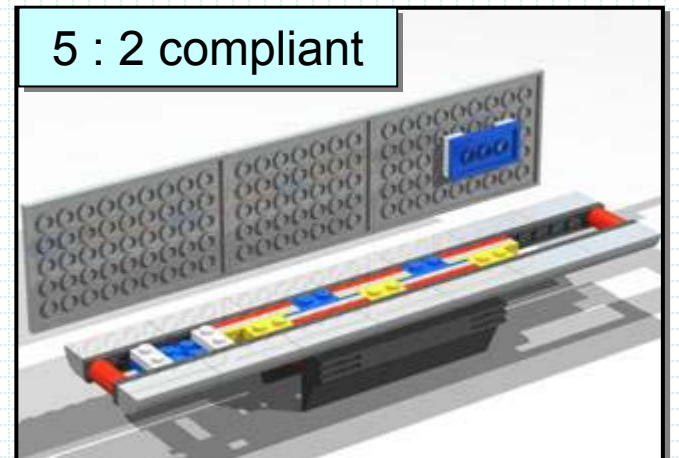
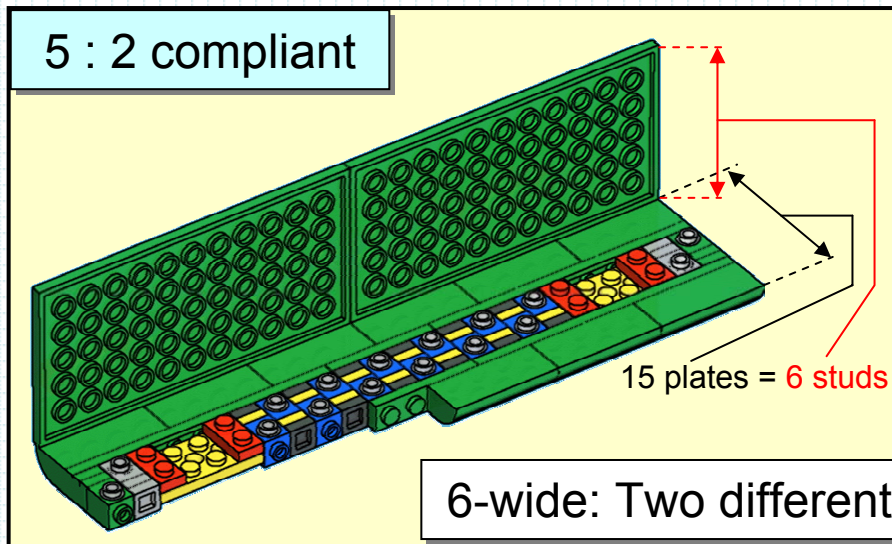

6-wide: Two different techniques achieve similar result.

1/4-Round Coach Underside by Barile

- By Steve Barile
 - Note texture relief by inseting 1/4-curved element by 1/2-plate
 - Simple and low piece count

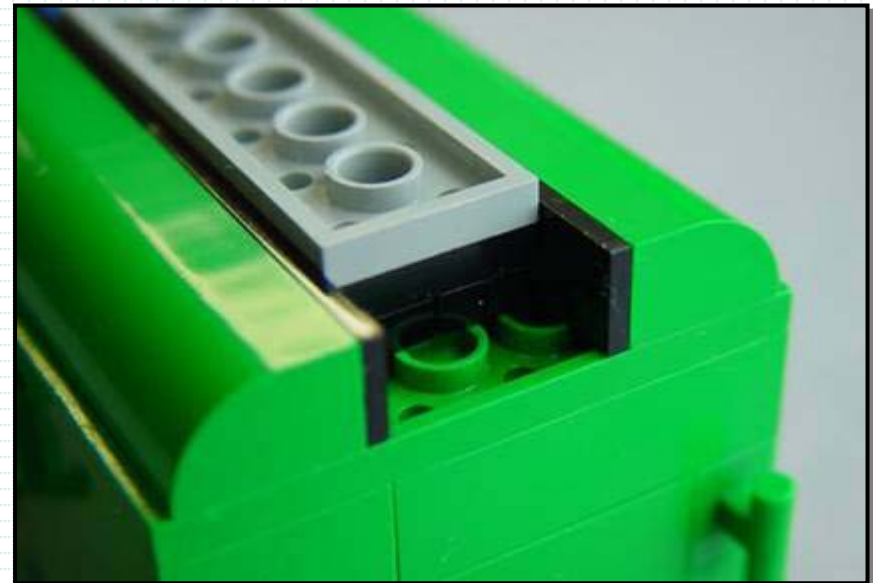

The 1x2x3 Panel and 3-Stud SNOT

- A SNOT-wise 3-stud plate fits into a 1x2x3 Panel
- Panel relief is 2 SNOT-wise plates deep
- Thin-wall of panel is $\frac{1}{2}$ -plate thick

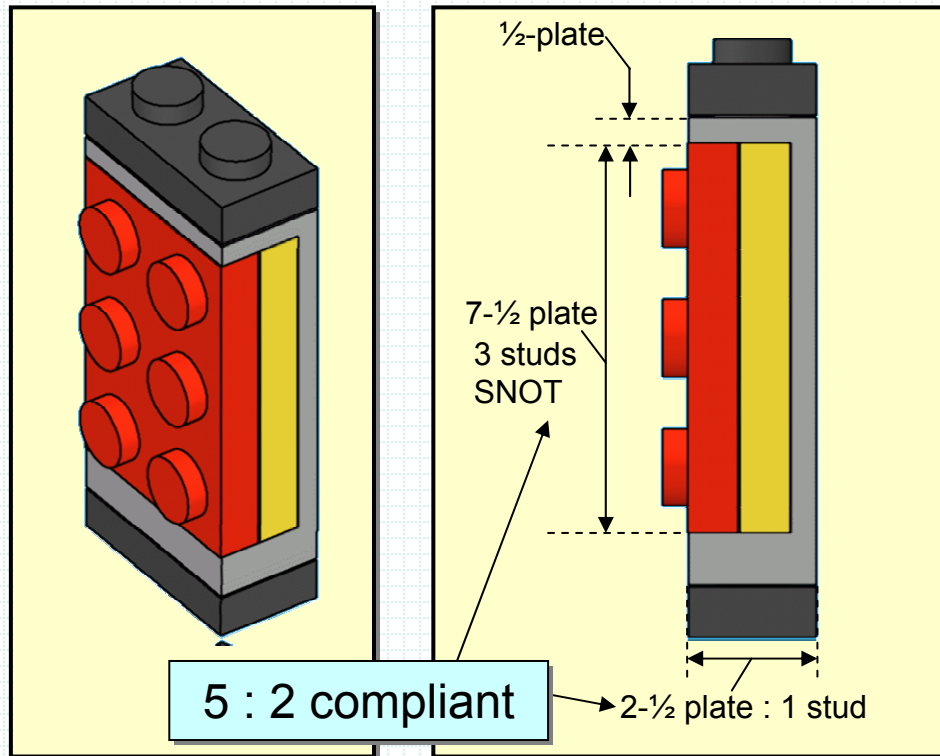

- Credit Jason Railton for bringing this geometry to public attention
- He points out that this construction will not work with a 1x4x3 thin-wall panel
 - 1x4x3 thin-walls have inner wall protrusions which interfere with the insertion of a SNOT-wise 3 stud tall plate

Uniform 1-Plate Thick Box Stripe

- Thin-Stripe Boxes by Steve Barile
 - Meets 5 : 2 criteria
 - Inner red area 1 brick tall

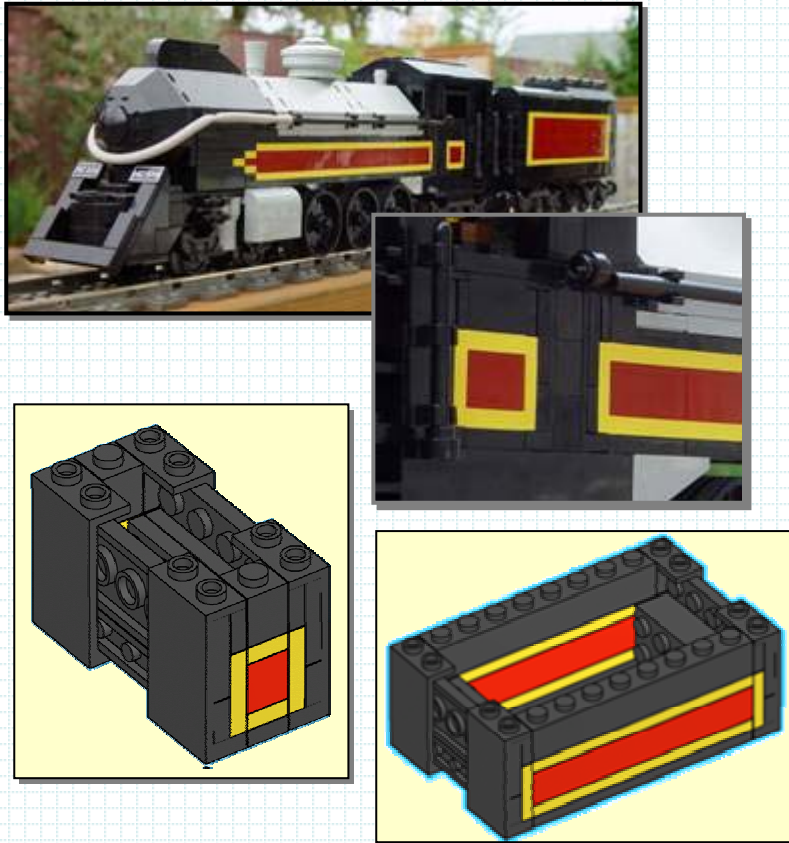

- Thin-Stripe Box by James Mathis
 - Meets 5 : 2 criteria
 - Inner red area 1 brick + 2.5 plates tall

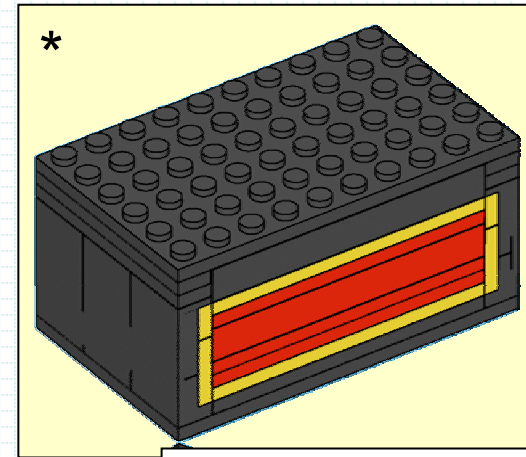

* Instructions available in back-up slides

These thin-stripe constructions are inspired by Jason Railton.

9-volt Train System Wheel Shroud

- 9-volt train wheels hidden behind a panel
- Based on 3-stud SNOT geometry

Development of this solution inspired by prior work by Jeremy Rear, David VinZant, and Steve Barile.

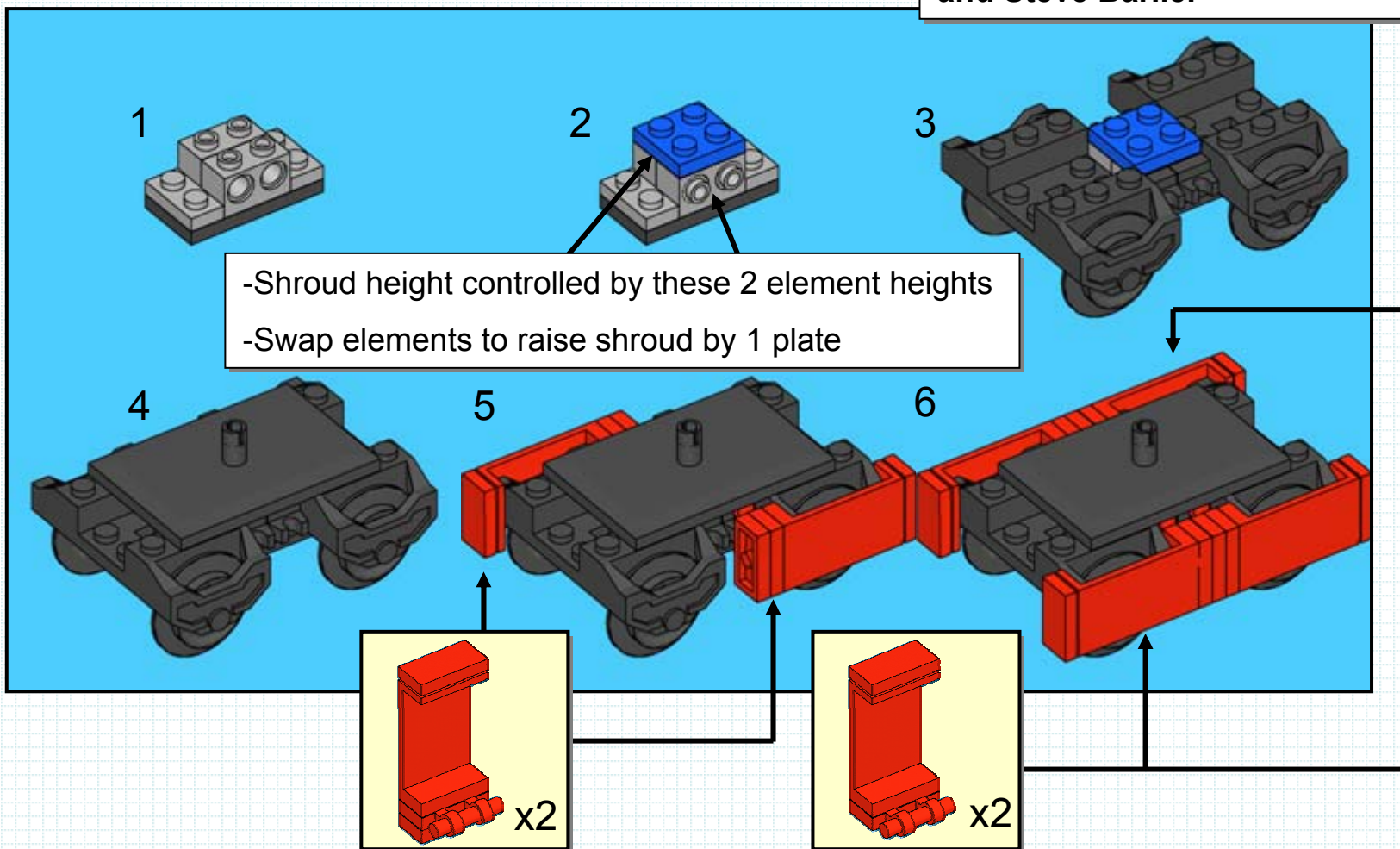



From Imagination to Reality

- Creation of a locomotive
- Inspiration
 - Study pictures of the real life locomotive
 - Personal interest
 - On-line collaboration
- Anatomy
 - Identify elements that fit critical design stylings
 - Arches
 - Windows
 - Roof elements
 - Define regions or modules of the model to construct
 - Possible sub-models
 - Independent stand-alone sections
- Build-Trials
 - CAD-design to quickly moc-up ideas
 - Test-fits of SNOT orientations for sub-models
- Refine design: Rebuild & Reconstruct

Real Life Locomotive & Inspiration

- German DB 103 Electric locomotive
 - Intercity Express passenger service
- Inspiration
 - Significance of 1981
 - I rode this train in 1981.
 - The LEGO® Company released a model of this train during the introduction of the gray-era 12-volt system in 1981.
- Realization
 - 20 years later
 - new elements
 - new original model



LEGO® is a registered trademark of The LEGO® Group of Companies which neither authorizes, endorses, nor commissions this presentation.

Anatomy of the DB103

- Sub-model Identification
 - Side vents
 - Roof
 - Electrics
 - Curved sides
 - Window
 - Round Nose
 - Tubular headlamps
- Red section height
 - Note red section is uniformly 7.5 plates thick
 - Curved red nose = 3 SNOT studs tall
 - Main red body = 7.5 plates tall
 - Satisfies 5 : 2 criteria





Summary & Conclusions

- Remember the 5 : 2 mantra
 - 5 plates = 2 studs
 - Works for ½-plates
- Think in terms of sub-models
 - Define sections of the main model that stand-alone at a different SNOT rotation
 - Use sub-models as construction “bricks” themselves.
- Familiarize yourself with a CAD construction program
 - Allows for quick SNOT studies
 - Nudge alignments of SNOT constructions
 - Check if a SNOT sub-model matches the 5 : 2 criteria
- SNOT isn't just for Trains
- The Fan-Community deserves credit
 - Inspiration
 - Education
 - Acceleration
 - Cooperation



Back-Up Slides

- Complete Instructions for
 - TGV lettering
 - Thin-stripe box of 1 brick + 2.5 plates tall inner area
 - German Electric Locomotive DB class 103

“TGV” Lettering Instruction Steps

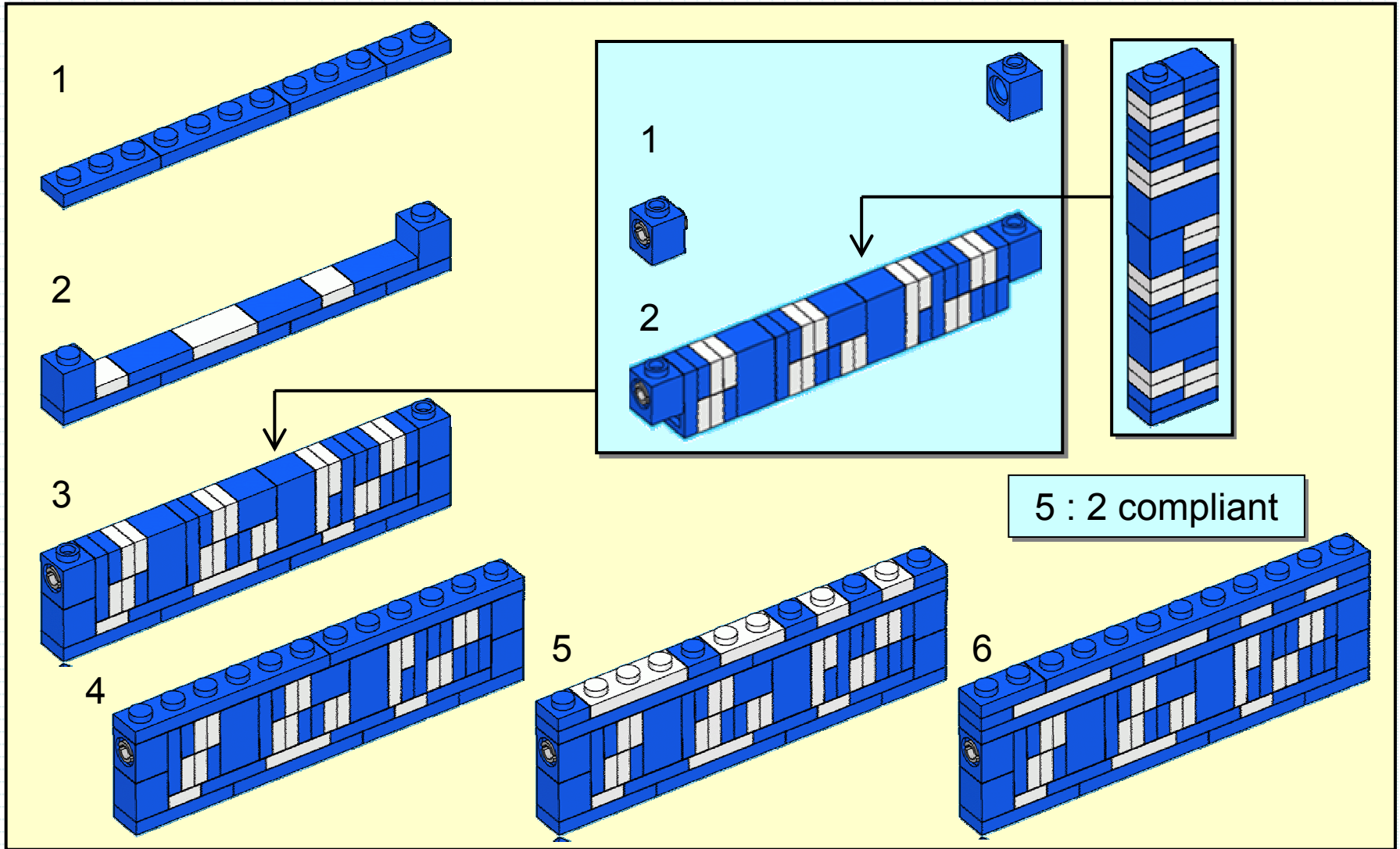

Uniform 1-Plate Thick Box Stripe (1of4)

- Technique introduced by Jason Railton
- This box design is the result of a collaboration between Steve Barile and James Mathis

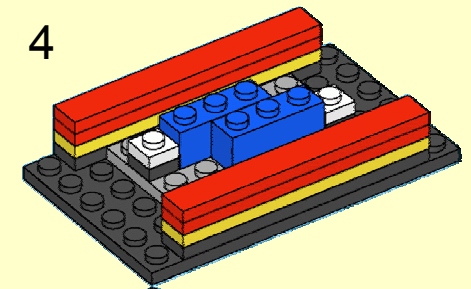
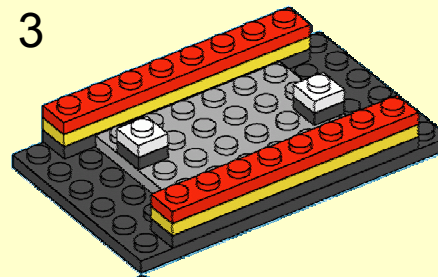
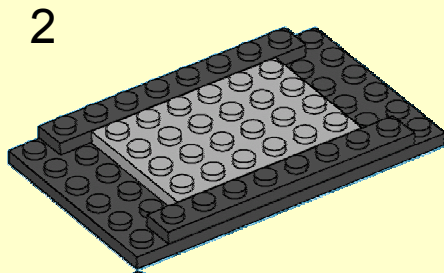
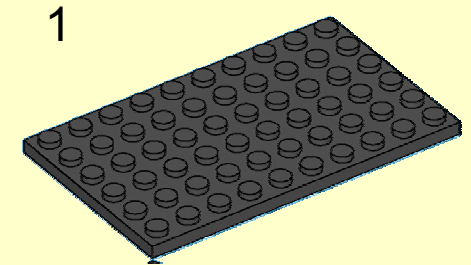
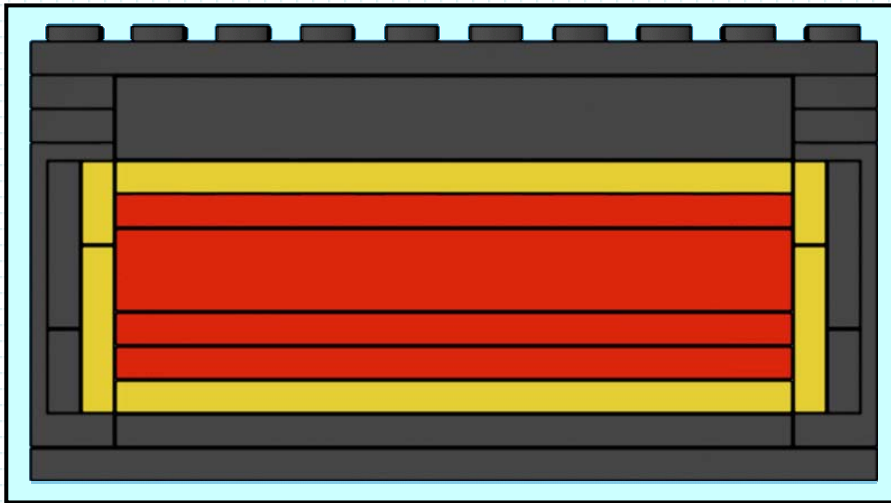

Uniform 1-Plate Thick Box Stripe (2of4)

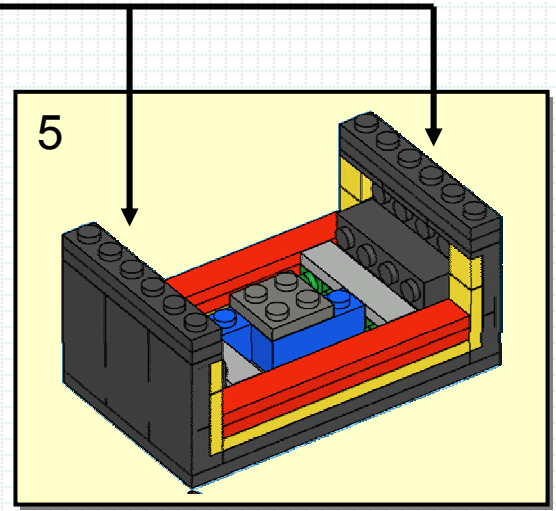
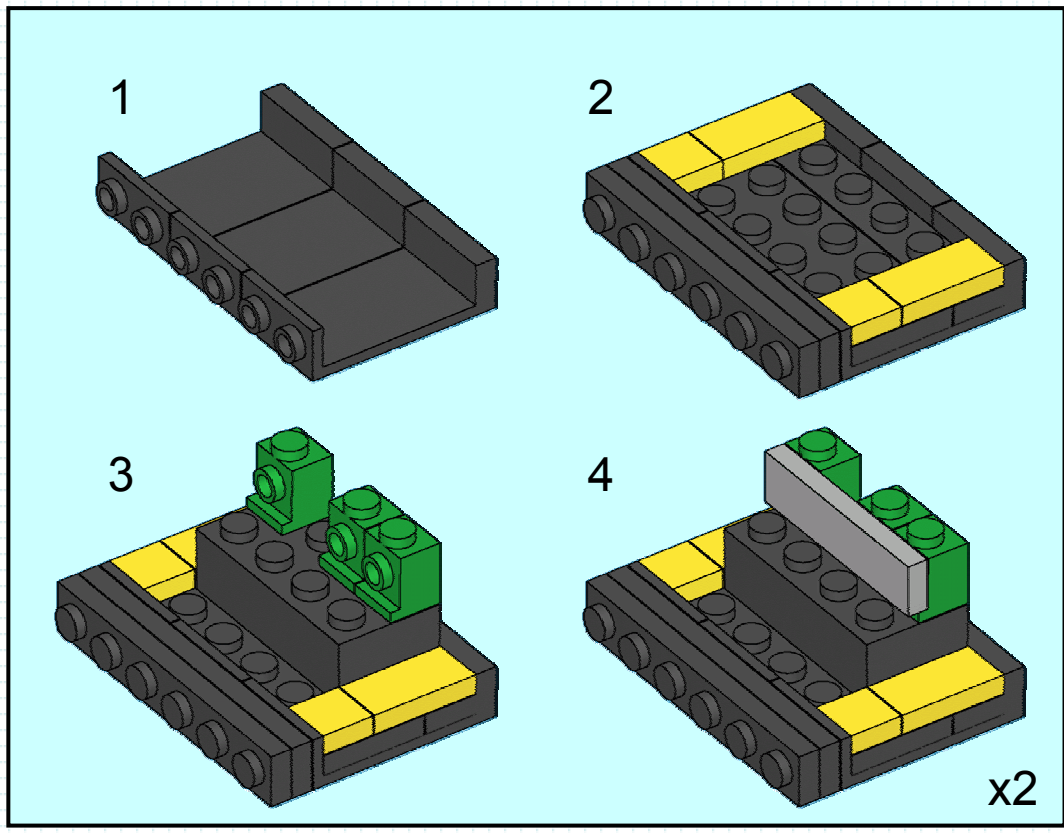

Uniform 1-Plate Thick Box Stripe (3of4)

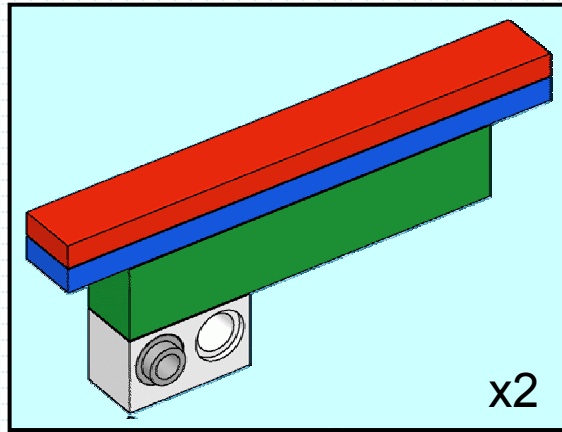

-A 3-stud tall SNOT thin-stripe (yellow) defines a box whose inner area is 5- $\frac{1}{2}$ -plates tall

-Fill area must contain a $\frac{1}{2}$ -plate thickness

-Solution: SNOT a 1x8 red tile to get 2- $\frac{1}{2}$ -plate filler

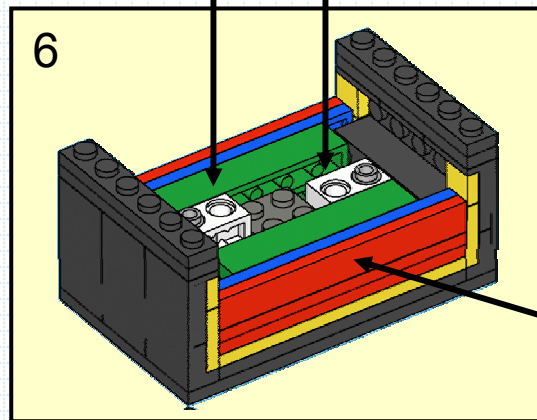

Uniform 1-Plate Thick Box Stripe (4of4)

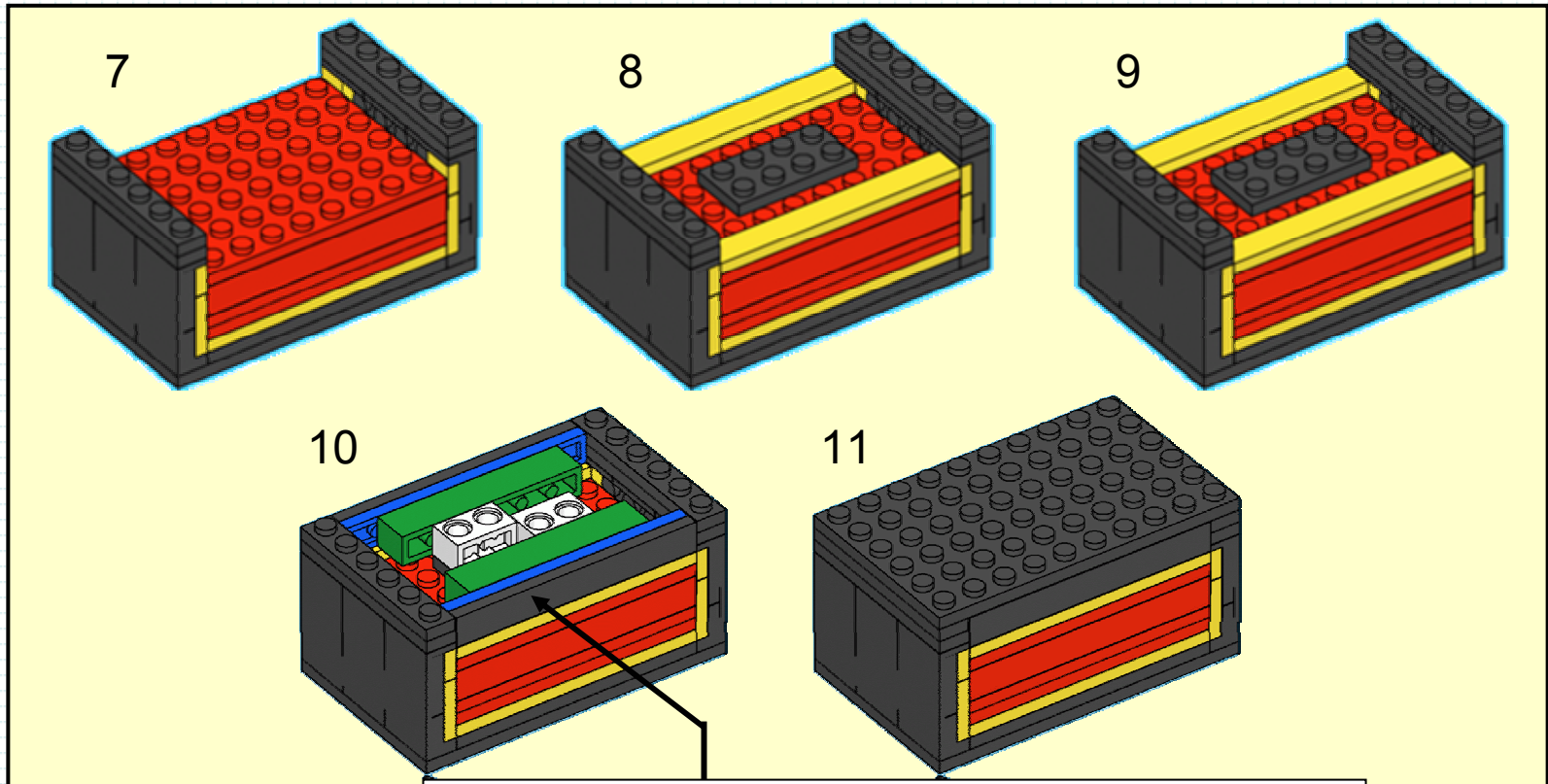

-Remaining height to fill is 2-½-plate thick
-Must SNOT another 1x8 tile to fill area