

OXFORD

Beehive

American

Workbook

2



Tamzin
Thompson

Beehive

American Workbook

2

| | | |
|----------------------|--------------------|-----|
| Starter Unit | Hello Again! | 2 |
| Unit 1 | Time for School | 4 |
| Unit 2 | Mealtime | 16 |
| Unit 3 | Wild Animals | 28 |
| Unit 4 | My Favorite Things | 40 |
| Unit 5 | Around Town | 52 |
| Unit 6 | On the Weekend | 64 |
| Unit 7 | My Day | 76 |
| Unit 8 | My Talents | 88 |
| Unit 9 | My Home | 100 |
| Unit 10 | Days Out | 112 |
| Grammar Check | | 124 |
| Wordlist | | 134 |



Tamzin Thompson

OXFORD
UNIVERSITY PRESS

3 Write the letters.



1 How do you spell  ?

N _____



I N N A



2 How do you spell  ?



C O R T H E



3 How do you spell  ?



M E A M

4 Write the numbers.

11
eleven

twelve

thirteen

fourteen

twenty-five

thirty

forty

fifty

sixty

seventy

eighty

ninety

one hundred

5 Write the number words in order.

- 1 15 16 17 fifteen sixteen seventeen
- 2 90 100 80 _____
- 3 20 19 18 _____
- 4 50 30 40 _____

1

Time for School!

Lesson 1 Words

1 Read and number.

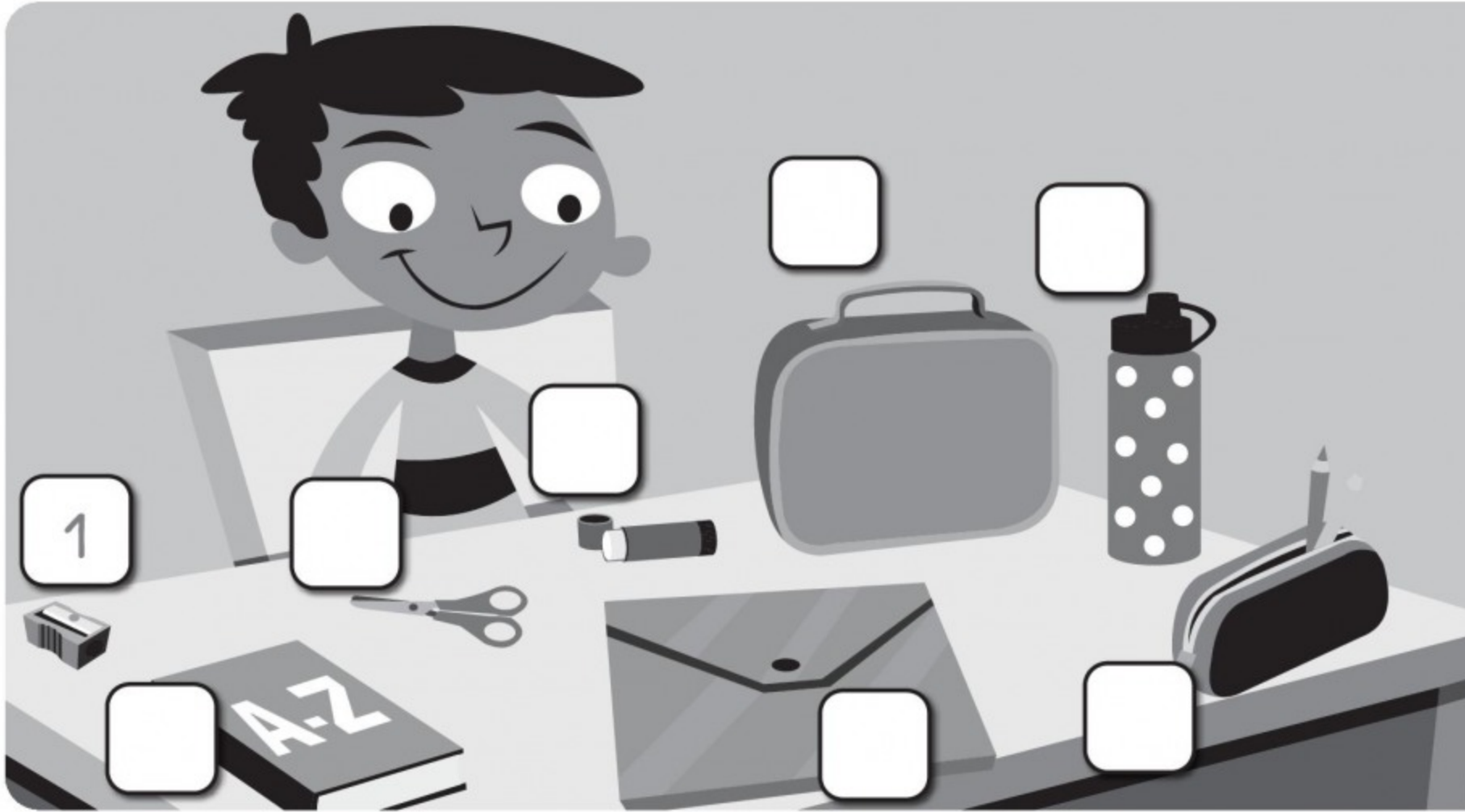

- 1 pencil sharpener
- 2 scissors
- 3 lunch box
- 4 pencil case
- 5 water bottle
- 6 dictionary
- 7 folder
- 8 glue stick

2 Write.



lunch box

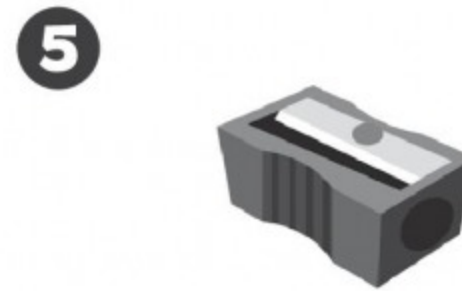

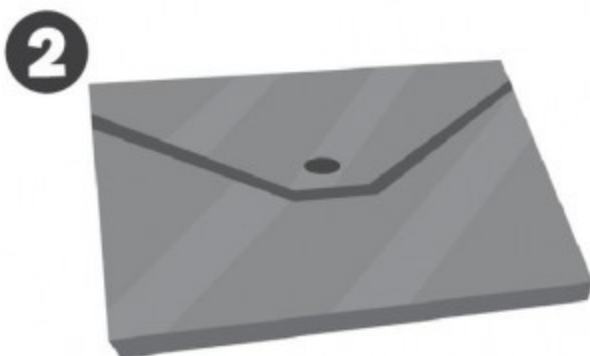





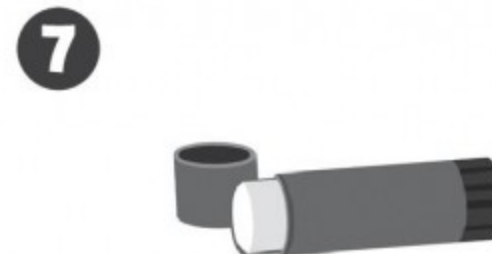



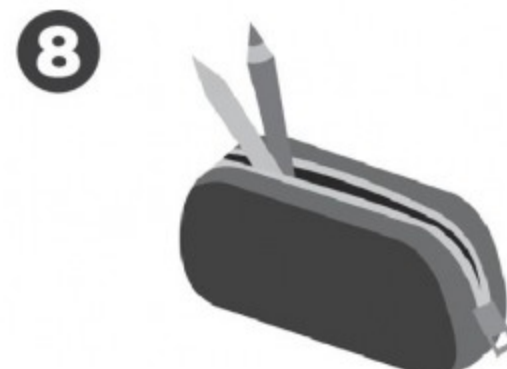

3 Draw. Then complete the sentences.

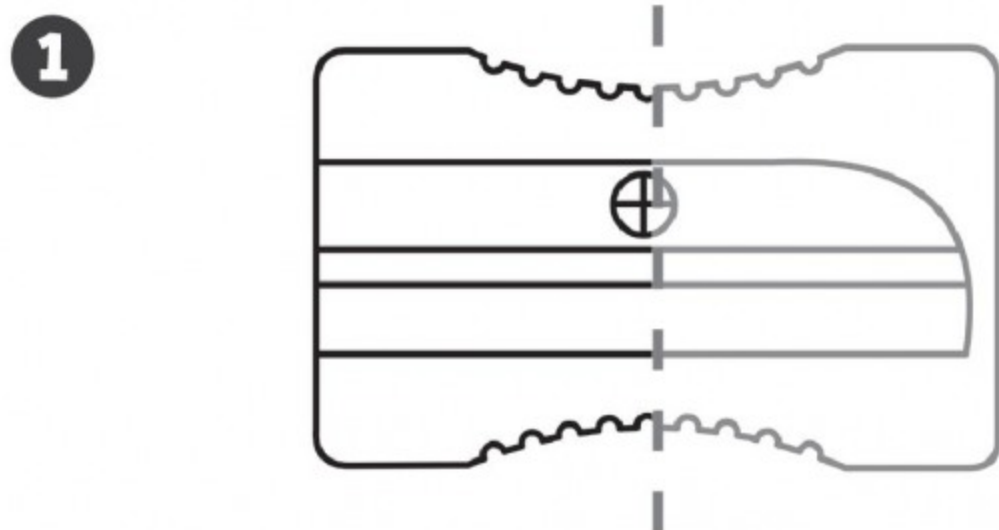

This is a pencil sharpener.

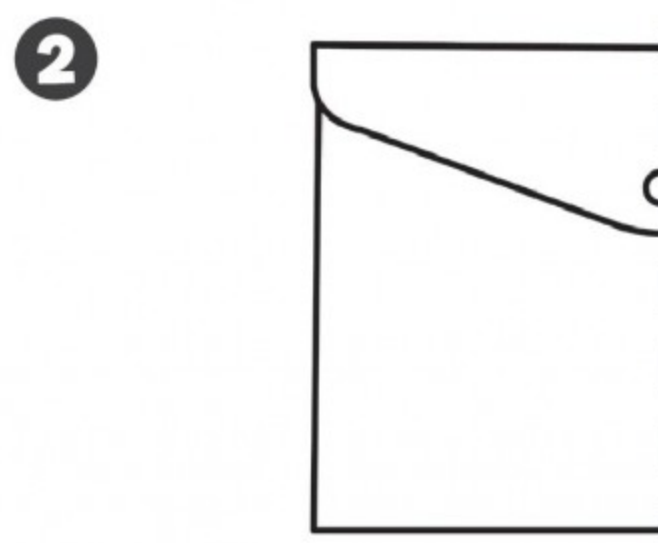

This is a _____.

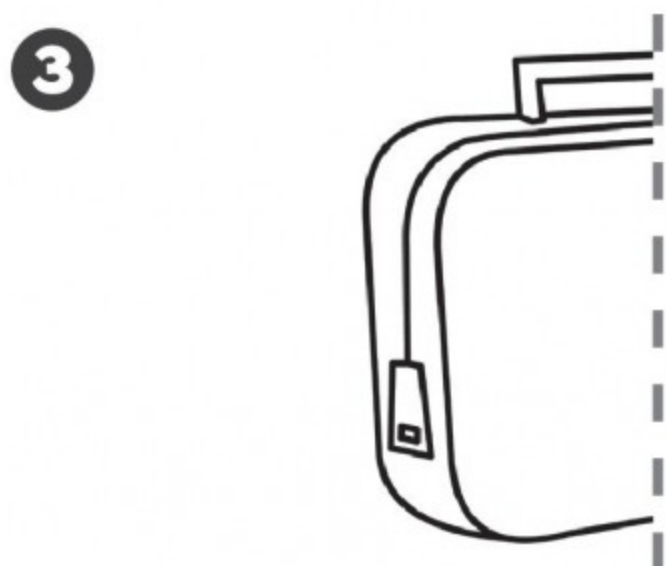

This is a _____.

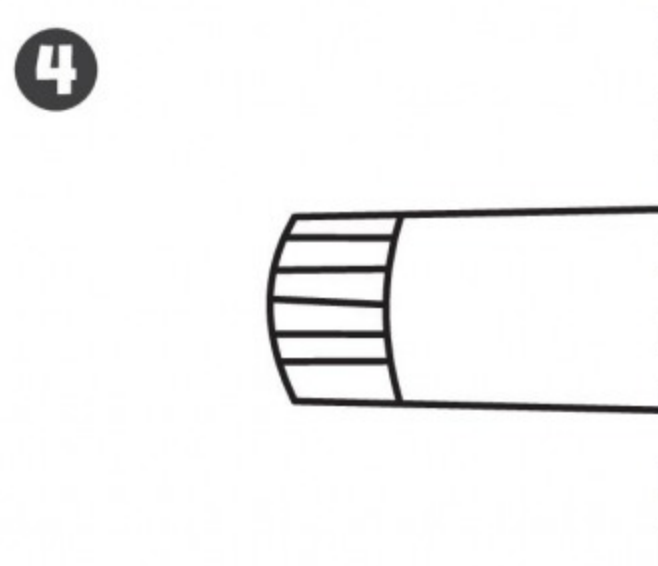

This is a _____.

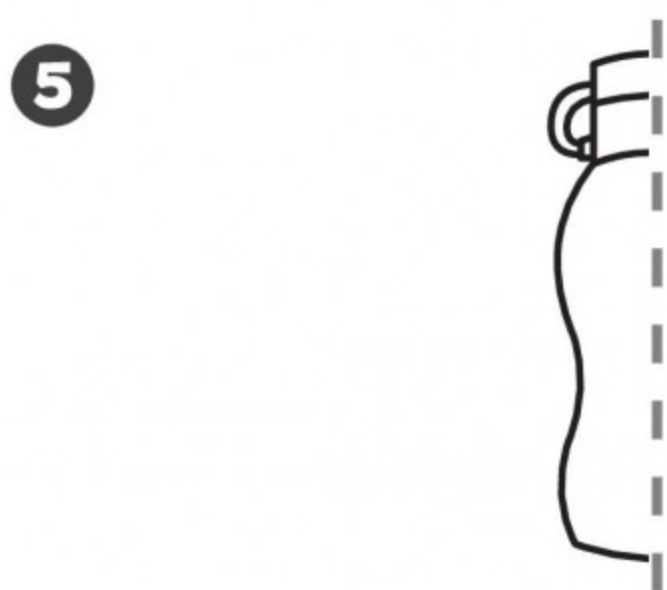

This is a _____.

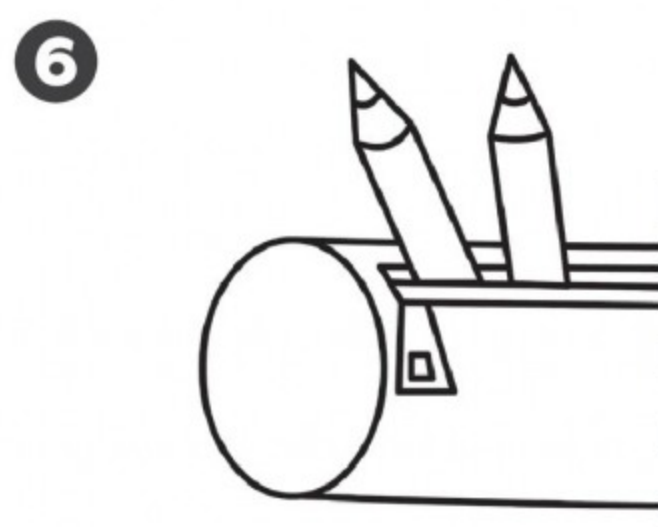

This is a _____.

4 Read and complete. **Here** **Can** **Sure** ~~use~~



1 Look, read, and circle Jenna's answers.



Jenna

- 1 Do you have a dictionary?
Yes, I do. / No, I don't.
- 2 Do you have a pencil sharpener?
Yes, I do. / No, I don't.
- 3 Do you have a water bottle?
Yes, I do. / No, I don't.
- 4 Do you have scissors?
Yes, I do. / No, I don't.
- 5 Do you have a folder?
Yes, I do. / No, I don't.
- 6 Do you have a lunch box?
Yes, I do. / No, I don't.

2 Circle the things you have.



3 Look at 2. Write answers for you.

- 1 Do you have a glue stick?
- 2 Do you have a pencil sharpener?
- 3 Do you have a folder?
- 4 Do you have a dictionary?
- 5 Do you have a pencil case?
- 6 Do you have scissors?

4 Look, read, and check ✓.



Ella



Max

- | | | | | |
|-------------------------------------|----------------|--------------------------|------------------|-------------------------------------|
| 1 Does Max have a water bottle? | Yes, he does. | <input type="checkbox"/> | No, he doesn't. | <input checked="" type="checkbox"/> |
| 2 Does Ella have scissors? | Yes, she does. | <input type="checkbox"/> | No, she doesn't. | <input type="checkbox"/> |
| 3 Does Max have a pencil sharpener? | Yes, he does. | <input type="checkbox"/> | No, he doesn't. | <input type="checkbox"/> |
| 4 Does Ella have a lunch box? | Yes, she does. | <input type="checkbox"/> | No, she doesn't. | <input type="checkbox"/> |
| 5 Does Max have a dictionary? | Yes, he does. | <input type="checkbox"/> | No, he doesn't. | <input type="checkbox"/> |

5 Look, read, and write.



- Does she have a pencil case?
Yes, she does.
- Does he have a folder?

- Does she have a glue stick?

- _____ water bottle?
No, he doesn't.
- _____ dictionary?
Yes, he does.

1 Write. **soccer shoes** **shorts** **sneakers** ~~tracksuit~~ **sports bag** **soccer jersey**

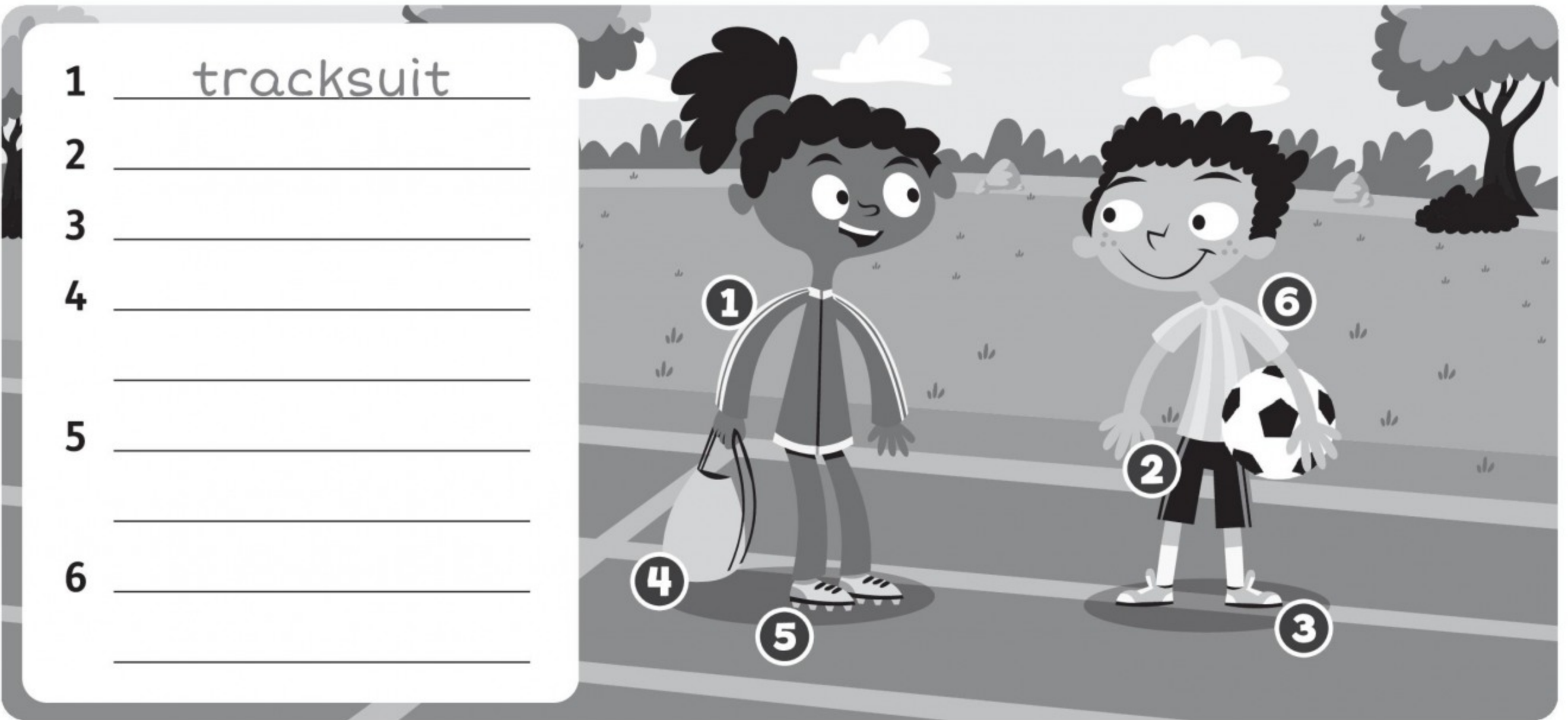

- 1 tracksuit
- 2 _____
- 3 _____
- 4 _____
- 5 _____
- 6 _____

2 Look, read, and complete.



- 1 Do you have shorts ?
- 2 Do you have _____ ?
- 3 Do you have _____ ?

Yes, I do.



- 4 Do you have _____ ?
- 5 Do you have _____ ?
- 6 Do you have _____ ?

No, I don't.



3 Look, read, and circle.



- 1 We have our / their soccer shoes. They have our / their sneakers.
- 2 They have our / their tracksuits. They have our / their sports bags.
- 3 We have our / their soccer jerseys. We have our / their shorts.

4 Look, read, and write.



- 1 We have our _____ sports bags.
- 2 They have _____ soccer balls.
- 3 _____ soccer jerseys.
- 4 _____ water bottles.
- 5 _____ shorts.
- 6 _____ tracksuits.

1 Look at the pictures. What school things can you see?

2 Read the story.

The Big Picture

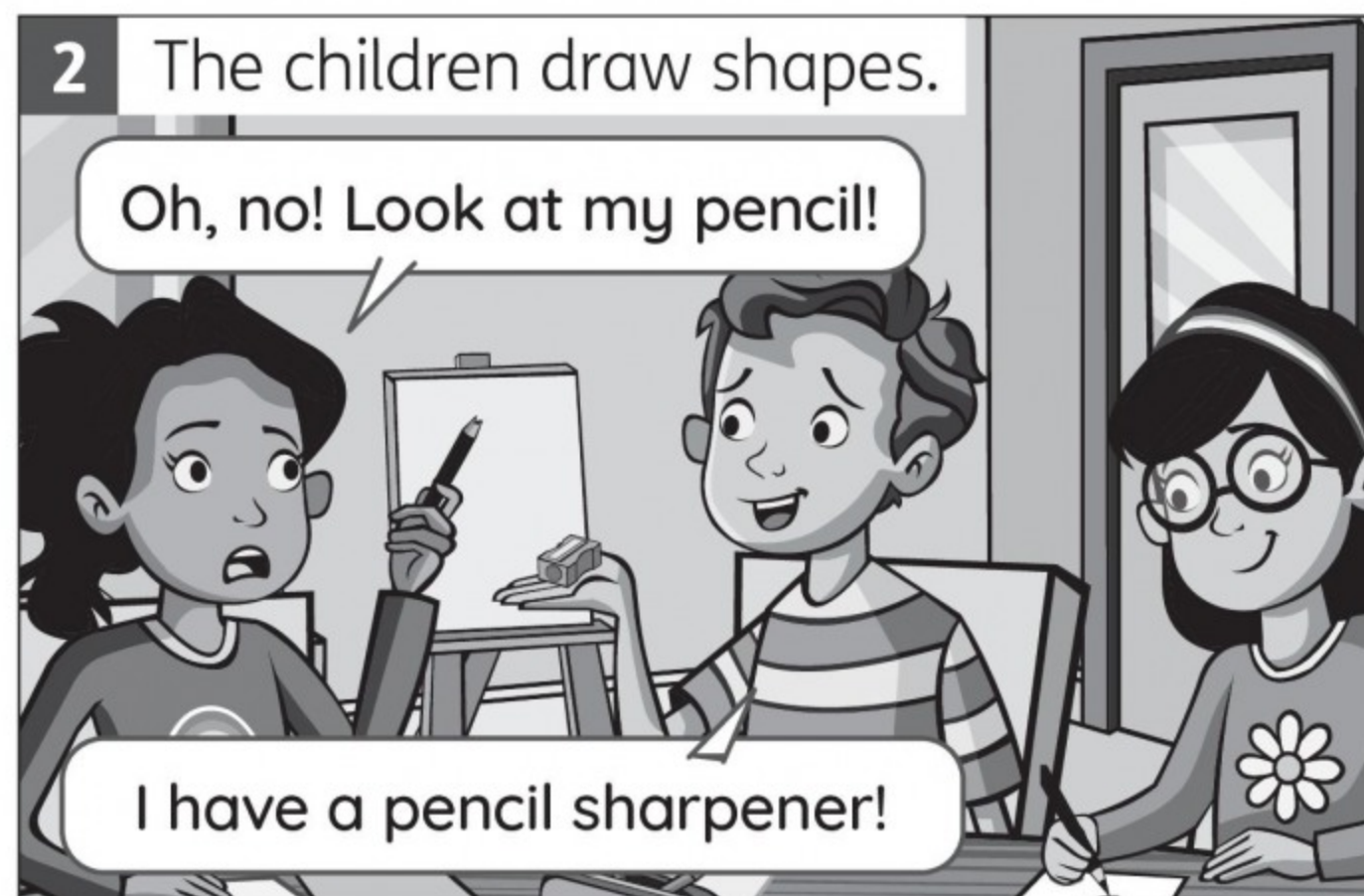

3 Read the story again. Write *T* (true) or *F* (false).

- 1 The children have triangles. T
- 2 Liam has a pencil sharpener.
- 3 Holly and Aliya don't have a glue stick.
- 4 Liam, Holly, and Aliya make a fish picture.
- 5 Liam, Holly, and Aliya are the winners.

4 Order the words. Who says it? Number.

- 1 my Look pencil! at

Look



- 2 use glue stick? I your Can



- 3 my have scissors! I don't



5 Circle, check ✓, and color.



1 Circle.
My favorite part of the story is

1 2 3

4 5 6

2 Check ✓.
My favorite character is



 

3 Color.
How many stars for the story?



Reading

1 Write. **crayons** **paints** ~~paper~~ **paintbrushes**

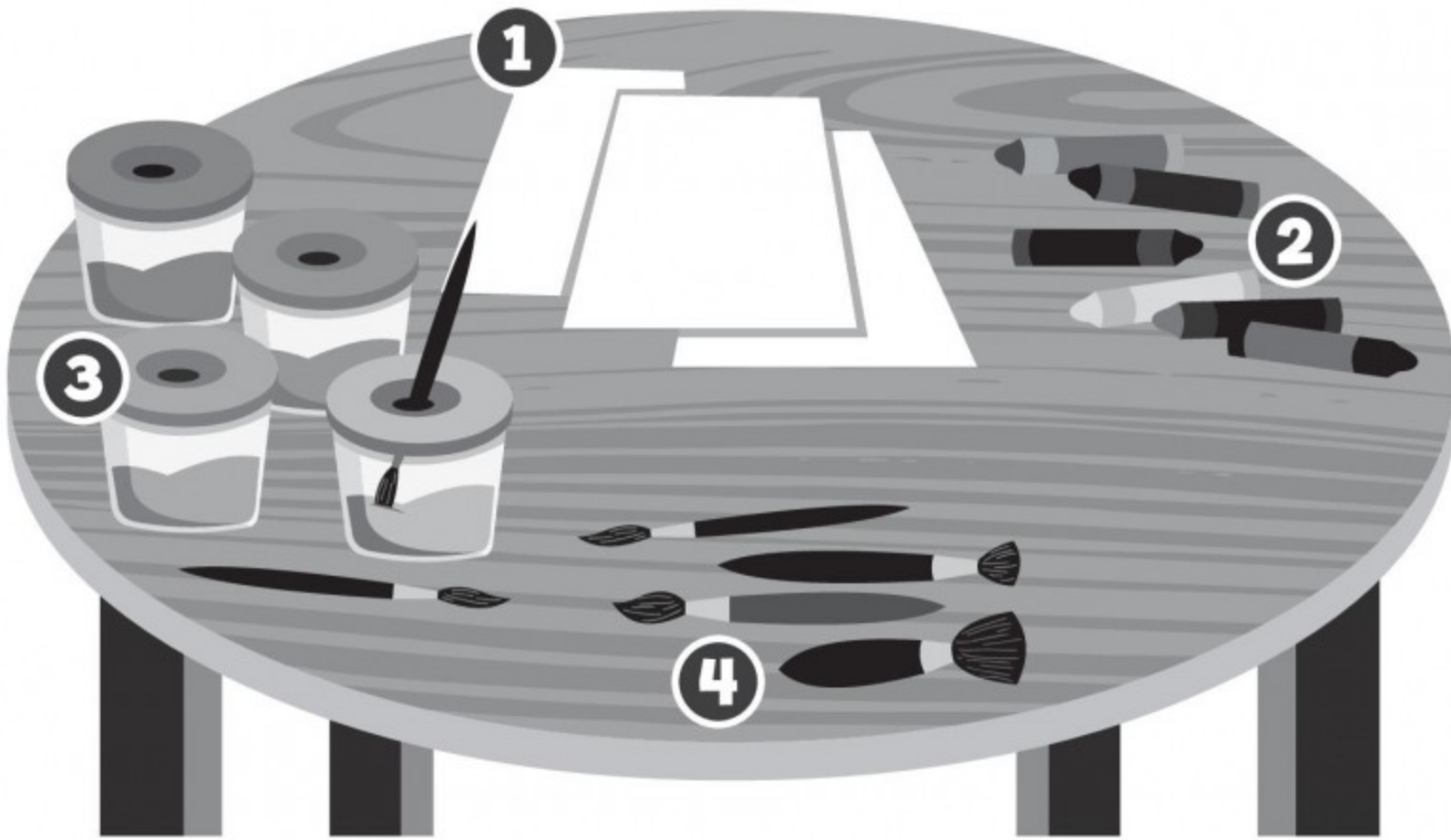

1 paper

2 _____

3 _____

4 _____

2 Read. Correct the sentences. Change one word.

FROM martin@oup.xyz.com TO carla@oup.xyz.com

SUBJECT My School

Hi, Carla!

Here are some photos of my school. My school is in Quebec. It has a big playground.

I am in second grade. My classroom has twelve desks and twenty-four chairs! It has a lot of pictures on the walls. My teacher is Mrs. Bisset. She's very nice.

It's time for art. We have crayons and paper. We have paintbrushes and paints, too. I love art! Write soon!

Martin





1 Martin's school has a big yard.

playground

2 Martin's classroom has twelve chairs.

3 Martin's friend is Mrs. Bisset.

4 Martin has pencils and paper for art.
